

CHAPTER 7: RECYCLING AND REUSE OF SEWAGE

***“No higher quality water should be used for a purpose that can tolerate a lower grade”
UN Council Resolution-1958***

“Many of the wars this century were about oil, but those of the next century will be over water.”- Ismail Serageldin, Vice President, World Bank-1995

Question to finalists

Technology is good for comfortable life; It is also blamed for environmental problems; How do you link Technology & Environmental Conservation?

Answer by winning finalist

Agrarian economy must reuse water safely

From the Miss Earth contest, Manila, Sponsored by WHO 2001

“Water should not be judged by its history, but by its quality.” Dr. Lucas van Vuuren, one of the pioneers of the Windhoek water reclamation system.

7.1 INTRODUCTION

With 80 countries and 40% of the world's population facing chronic water problems and with the demand for water doubling every two decades, these extracts mentioned above merit action. The largest source of reuse resides in agriculture and the equally largest misplaced resource is sewage in the habitations. In the “Handbook on Service Level Benchmarking” by MoUD, reuse and recycling of sewage is defined as the percentage of sewage recycled or reused after appropriate treatment in gardens and parks, irrigation, etc. and, is to be at least 20% to begin with. The objective of this chapter is to bring out guiding principles for practice in India.

7.1.1 Overview of Current Practices in India

In India treated sewage is being used for a variety of applications such as (a) Farm Forestry, (b) Horticulture, (c) Toilet flushing, (d) Industrial use as in non-human contact cooling towers, (e) Fish culture and (f) Indirect and incidental uses. They are briefly mentioned hereunder.

- a) The CMWSSB has been promoting the growth of farm forestry in Chennai from the 1980s and this helps to promote a micro climate in a city environment.
- b) The Indian Agricultural Research Institute, Karnal has carried out research work on sewage farming and has recommended an irrigation method for sewage fed tree plantations.
- c) The University of Agricultural Sciences, Dharwad, Karnataka has found that sewage could be used in producing vermicompost to be used for tree plantations provided its details with respect to composition of toxic substances are known.
- d) Chandigarh is using treated sewage for horticulture needs of its green areas.
- e) Delhi has put in place planned reuse of treated sewage for designated institutional centres.

- f) The Government of Karnataka has issued an official directive to take all necessary steps to ensure that only tertiary treated sewage is used for non-potable purposes, like all gardening including parks, resorts and golf course. The Bangalore Water Supply and Sewerage Board will make all arrangements including construction of filling points, installation of vending machines at STP for supply of tertiary treated sewage in multiples of thousand litres and that non-compliance of the directions attracts penal provisions in accordance with section 15 and section 17 of the Environment (Protection) Act 1986.
- g) In major metropolitan cities like Delhi, Mumbai, Bangalore and Chennai treated grey water is being used for toilet flushing in some of the major condominiums and high rise apartment complexes on a pilot scale. Care should be taken to ensure that Ultra filtration membranes are used in the treatment process to safeguard against chances of waterborne diseases.
- h) Secondary treated sewage is purchased and treated for use in cooling water makeup in the industrial sector from as early as 1991 in major industries like Madras Refineries, Madras Fertilizers, GMR Vasavi Power plant in Chennai as also in Rashtriya Chemicals and Fertilizers in Maharashtra and most recently in the Indira Gandhi International Airport in Delhi and Mumbai International Airport.
- i) In Kolkata, the Mudiali fish farm occupying an area of 400 hectares is used for growing fish, which is then sold for human consumption.
- j) The UNDP conducted a detailed study in the 1970s and identified a sand basin on the coast of Bay of Bengal, where secondary treated sewage of the Chennai city can be infiltrated through percolation ponds and extracted for specific industrial use in the nearby petro-chemical complex. However, this project has not been implemented.
- k) The Bengaluru city is facing a freshwater crisis and it has been considered to study a pilot model of the Singapore NEWater for indirect augmentation of water by advanced treatment of secondary facilities. At present, this project proposal is a statement of capability to formulate a technically feasible and financially viable project and of course the biggest challenge of going through and obtaining public acceptance is understandably a long drawn out process.

7.1.2 Overview of Current Practices in the World

The use of treated sewage elsewhere in the world is listed herein and in Appendix 7.3.

- a) Agriculture: It is used for irrigation in certain places in Africa, Israel, Mexico and Kuwait.
- b) Farm Forestry: Treated sewage is used for watering urban forests, public gardens, trees, shrubs and grassed areas along roadways in certain places in Egypt, Abu Dhabi, Woodburn in Oregon USA. It is also used for timber plantation in Widebay Water Corporation in Queensland, Australia. It is used for alfalfa plantation in Albirch Palestine.
- c) Horticulture: Certain places in Elpaso in Texas, Durbin Creek in Western California in USA.
- d) Toilet flushing: Certain locations in Chiba Prefecture, Kobe City, and Fukuoka City and Tokyo Metropolitan in Japan.

- e) Industrial and commercial: essentially used for cooling purposes in Sakaihama Treated Wastewater Supply Project, Japan, Bethlehem Steel mills, USA. Sewage reclaimed as high quality water is supplied to Mondi Paper Mill and SAPREF Refinery in Durban, South Africa. Landscape and golf course irrigation in Hawaii,
- f) Fish culture: It is used in fish hatcheries / fish ponds in Vietnam and in Bangladesh
- g) Groundwater recharge: Orlando and Orange County Florida, Orange County California, Phoenix (Arizona), Santa Rosa (California) Recharge Project all in USA.
- h) Indirect recharge of impoundments: Restoration of Meguro River in Japan, NEWater project in Singapore, Windhoek in Namibia, Berlin in Germany
- i) Other uses: Coach cleaning, subway washing and water for building construction is being practised in Jungnang, Nanji, Tancheon, Seonam in Seoul and treated sewage sprinkled on the water retentive pavement that can store water inside paving material at Shiodome Land Readjustment District (Shio Site) in Tokyo and this reduces the surface temperature.

7.2 CASE STUDIES IN RECYCLING AND REUSE OF SEWAGE

7.2.1 Raw Sewage Treatment and Reuse as Cooling Water at M/S GMR Vasavi Power Plant, Chennai, India

7.2.1.1 The Pride of Place

This plant is the first of its kind in Asia commissioned as early as 1999, where the raw sewage of Chennai city is treated to recover (a) water of grade suitable for makeup in the cooling water and (b) is also further treated to recover a water of boiler grade.

7.2.1.2 Treatment Schematic

This is shown in Figure 7.1.

7.2.1.3 Raw and Recovered Sewage Qualities

These are given in Table 7.1 and Table 7.2

7.2.1.4 Step by Step Reasoning of the Treatment

Need for Equalization Basin Up Front: The flow of sewage is not uniform throughout 24 hours and the biological treatment plant can absorb the fluctuations and still yield a fairly steady level of treated sewage quality. However, in the Lime addition of the chemical system, the flow rate should be necessarily uniform, to facilitate dosing of chemical uniformly. This implies flow equalization necessarily at some point. It was decided to have this before the biological treatment itself, so that the dosage of Sodium bicarbonate whenever needed (before the primary clarifier to ensure adequate bicarbonate alkalinity for biological nitrification in the aeration tank) can be controlled easily in a steady state, which will further avoid unduly high Sodium in the resulting sewage. An example of sizing the equalization tank volume is given in Appendix A.5.2.

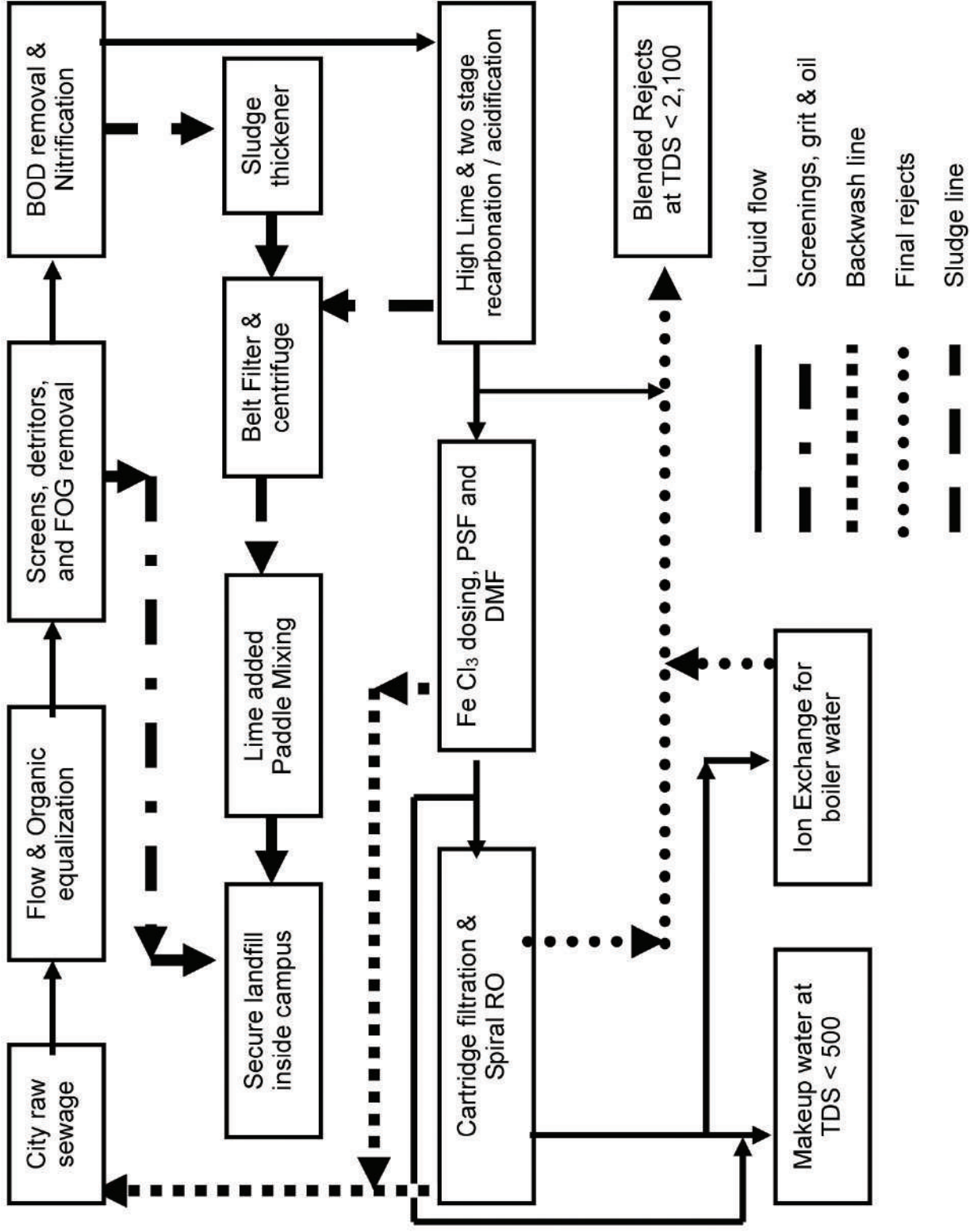

Figure 7.1 Treatment schematic of the M/S GMR Vasavi power plant sewage reuse plant

Table 7.1 Raw sewage quality variations taken for the design

No.	Parameters	Max	Min	No.	Parameters	Max	Min
1	pH	7.9	7.6	14	Phe. Alk. as CaCO ₃		
2	Total Dis. Solids	1360	980	15	Total Alk. as CaCO ₃	670	530
3	Inorg. Dis. Solids	95%	94%	16	Sodium as Na	370	280
4	Suspended Solids	590	460	17	Chloride as Cl	400	380
5	BOD 5 days 20°C	540	350	18	Sulphates as SO ₄	130	130
6	COD, 2 hours reflux	850	520	19	Oil and grease	16	6.4
7	Ammonia N as N	60	37	20	Phenolics	0.5	0.45
8	TKN as N	105	83	21	Surfactants	7.8	5.8
9	Ortho P as PO ₄	33	28	22	Sulphide as S	16	11
10	Total P as PO ₄	39	35	23	Fluoride as F	1.2	0.9
11	Ca as CaCO ₃	170	120	24	Silica as SiO ₂	38	32
12	Mg as CaCO ₃	230	180	25	Summer temp. as °C	39.5	39
13	Tot Hardness, CaCO ₃	400	300	26	Winter temp. as °C	29	28

Table 7.2 Makeup water quality required for recirculation cooling

No	Parameters	Range	No	Parameters	Range
1	Langelier Index	0.1 to 0.2	4	Phosphate	Nil
2	Total Dis. Solids	550 to 600	5	Ammonia	Nil
3	Silica as SiO ₂	2 to 3	6	Others	As arising

In 1997, the aerators used were mostly slow speed surface aerators, and it was not easy to adjust the air input unlike the diffused aeration, where the VFD controlled motor permitted variations of air flow and hence, the oxygen input into aeration system based on the peak, average and lean flow durations could not be pro-rata adjusted. Hence, it was necessary for upfront equalization.

Before feeding to the RO plant, the ammonia and phosphorous have to be removed as these can cause corrosion of some metal surfaces and biofouling in the circulating water respectively.

For this purpose, ammonia removal options of high lime induced air stripping, biological nitrification, chlorination and Clinoptinolite resin exchange were evaluated and it was decided to follow the biological nitrification route, given its high degree of reliability and the fact that nitrates can be rejected in the RO and residual presence in permeate was not prohibited.

The combined BOD removal and ammonia nitrification in the same aeration tank was chosen because of its well proven performance in the Chennai TWAD Board R&D unit. Studies on field scale pilot plant validations of localized design criteria were carried out between 1965 to 1980 at Kodungaiyur R&D facility, which eventually became the forerunner for such prototype plants in India.

The desired cooling water makeup needed a quality where silica was to be restricted to less than 3 mg/l. The raw sewage silica content was about 38 mg/l. The magnesium (Mg) content was 180 mg/l at the minimum. This when precipitated at pH above 10.5, will reduce Mg to less than 25 mg/l. Thus Mg removal could be 155 mg/l. This can co-precipitate silica by $155/5 = 31$ mg/l, which meets the requirement of silica removal before entering RO to less than 5 mg/l, further by restricting the recovery at about 75%, the silica in the permeate can be held down to 1 mg/l and reject silica can well be about 20 mg/l.

Maximum removal of Mg is possible only at a pH of above 10 and hence, the high lime process of the biologically treated sewage was decided upon.

The incidental advantages of complete precipitation of phosphorous, alkaline oxidation of residual organic matter, destruction of colour and especially inactivating the pathogenic organisms after at least 45 minutes contact time and precipitation of heavy metals as their oxides were all recognized as incidental to the high lime process and hence this was chosen.

The neutralization of high lime treated effluent was chosen to be used through two stage carbonation, whereby the first stage will be cut off at a pH of about 9.3 to enable precipitation of the originally available calcium and the added calcium. The second stage neutralization will be to reach the pH of close to 6.5 which is the desired limit in RO feed water. The proposed carbon dioxide cylinders are easily available locally. Alternative acidification is also used.

The restriction in the disposal of the plant reject is governed by a TDS limitation of 2,100 mg/l. In order not to exceed this limit, the biological and chemical treatment segments were of higher capacity, than actually required to feed to RO to obtain the required permeate volume. The excess volume with a TDS reduced by about 550 mg/l in the chemical treatment segment was used to dilute the RO rejects.

Even though phosphorous precipitation was expected to be complete in the high lime stage, a backup was provided by dosing FeCl_3 on line and providing a static mixer after the carbonation in the feed pipe line of pressure sand filters.

A dual media filter was chosen to further filter out the chemically treated water, thereby ensuring that even a chance occurrence of phosphorous in the RO feed is avoided entirely. By this, the contributory cause of bio fouling of the RO membrane could also be avoided. The treatment schematic as in Figure 7-1 (overleaf) above was thus chosen to be implemented.

7.2.1.5 Key Design Criteria

- Primary and secondary clarifiers were generally as per CPHEEO guidelines
- Sludge withdrawal was by direct suction to ensure adequate velocity of drawal
- The F/M value was 0.25 and HRT for DWF was 8 hours in aeration tank
- Alpha and Beta Factors were 0.75 and 0.95 with residual DO of 2 mg/l
- The MLSS was designed at 2,500 mg/l and was adjusted based on field conditions

- Mixing power was maintained at 20 watts per cum of aeration tank volume
- HRT in excess lime and first carbonation clarifiers were as per CPHEEO guidelines
- RO system design was as per the membrane manufacturer.

7.2.1.6 Performance Results

The plant is in continuous O&M ever since 1999 and has attained the desired key criteria of TDS less than 600, silica almost nil, etc. besides clear and colourless nature of the RO feed ever since.

7.2.1.7 Pointers for the Future

The expected precipitation of calcium in the first stage carbonation was sometimes erratic leading to calcium escape. Though this was dissolved into bicarbonate in the second stage carbonation, at times this was difficult and the neutralization was switched over to use of hydrochloric acid. This increased the calcium content in feed to RO and required readjustments of the blending to peg the TDS in the product water. The use of a solids contact clarifier instead of the plain clarifier could have been a better choice, but the possibility of the calcium carbonate sludge solidifying therein, and choking the sludge withdrawal lines were the other issues.

Conventional precipitation of Ca and Mg could have been tried instead of high lime carbonation, but the fact that phosphorous even at 0.1 mg/l prevents solids liquid separation of the precipitated carbonate thus, defeating the objective was the reason. All the same, future plants need to carefully assess these options.

The original RO membranes of brackish water grade though were guaranteed for only 4 years by the manufacturer, lasted for as many as 7 years before the recovery dropped by 10%. This is clearly traceable to the total sterility of the water exiting the high lime stage.

Lately, the use of UF membrane has increased in India. The historical Water Factory 21 in California has also originally used the high lime carbonation route, but later changed over to microfiltration route. Though this may look attractive prima facie, the need to look into phosphorous removal, which can be fully possible only in high lime has to be borne in mind. Whereas the water factory was tackling the raw sewage phosphorous of only single digit, the plant cited here was tackling as much as 35 mg/l. In that case, there is no way, the MF or UF can eliminate phosphorous, especially, if it is in colloidal form.

Moreover, soaps and detergents in India continue to bring in inorganic phosphates in the raw sewage. As far as sewage is concerned, this single factor may lead to bio-fouling of RO membranes. A combination of high lime and UF would perhaps be the best available technology.

With respect to the sludge cake, the wet biological sludge from the filter press machines, was blended with the high Lime precipitated sludge, and the cake was further treated to raise the pH of the same to about 9.3 by a paddle mixer. The resulting sludge mass was being used to raise the low lying areas and served as a secure land fill in the clayey soil. This pH adjustment of the sludge cake was worthy of consideration.

7.2.2 Reuse Plant at Indira Gandhi International Airport, Delhi, India

This is the latest plant in India. The raw water is taken from local piped water as also from local bore well water as a backup & treated in RO. The rejects from this system, the sewage from the new terminal building and from the old infrastructure are all blended as a sort of pseudo sewage as different from conventional city sewage in regard to ammonia to BOD ratio being much higher. This was due to the nature of usage of toilets in the terminal building almost entirely for urination as compared to the water closets. This pseudo sewage was taken to a biological nitrification-denitrification reactor using the MLE process. Further, the biological treated sewage is equalized before being filtered through DMF after on line injection of FeCl to remove possible colloidal phosphorous, and thereafter through UF, cartridge filter and RO. The bio-reactor is unique in shape so that the plug flow configuration can be covered by a funicular polygon, if needed later on. The water balance in this plant is shown in Figure 7.2.

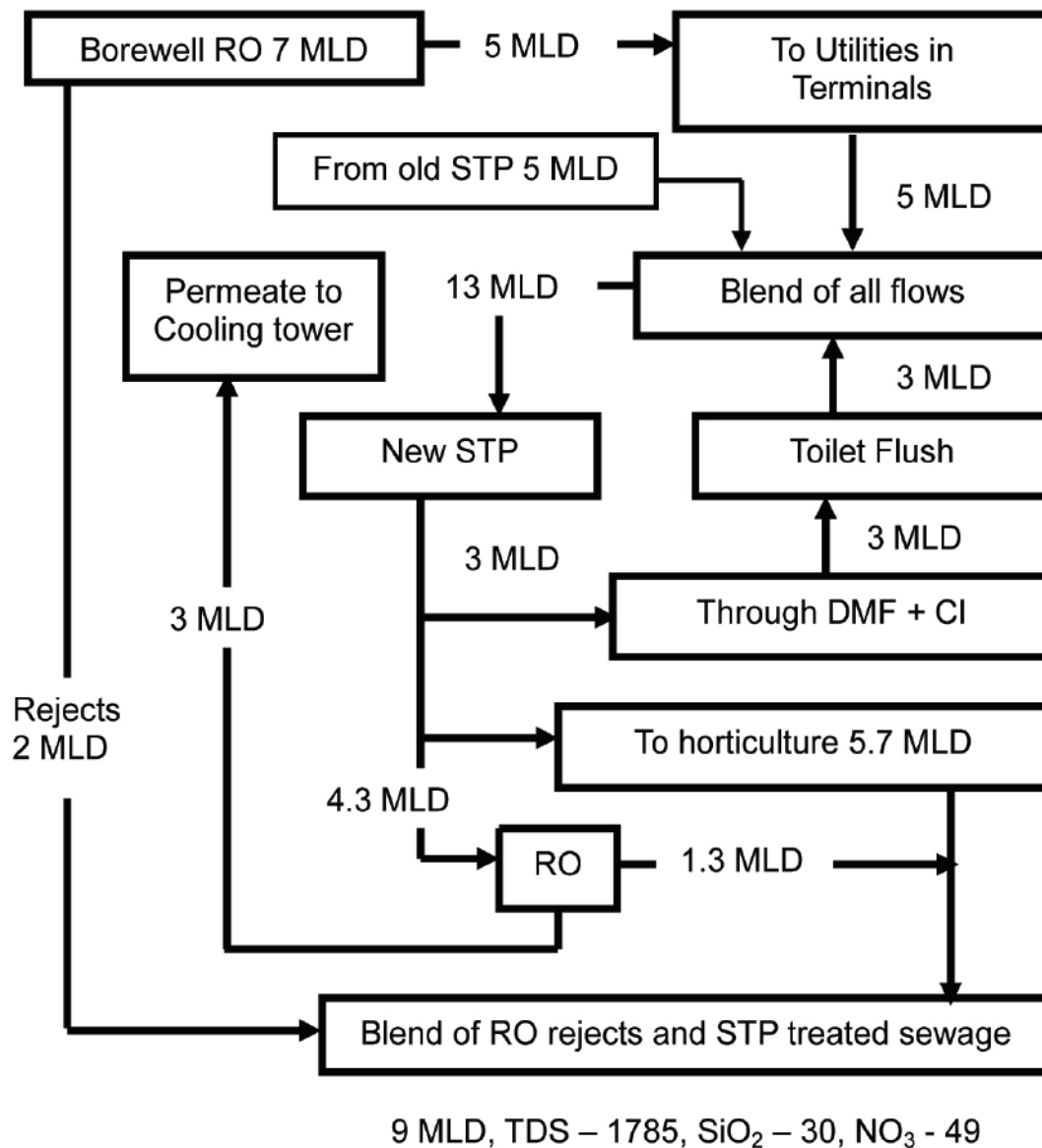

Figure 7.2 Water balance in the New Delhi IGI airport sewage reuse plant

7.2.2.1 Water Routing of this Plant

As shown in Figure 7-2, bore well water will be treated in RO and the product water supplied to the new Terminal building for utilities and potable uses. The treated sewage will be equalized for flow and filtered through Dual Media Filters (DMF) with on line FeCl_3 addition and reused partly in toilet flush as a water conservation initiative. This component will actually be a closed loop. The rest of the treated sewage will be split into two streams one for greenery and the other for RO to use the permeate as cooling tower makeup water. The rejects from the RO plants and the bypass of treated sewage will be blended and used for sustaining the greenery with maximum water conservation and ensuring blended TDS of less than 2100 mg/.

7.2.2.2 Key Design Criteria

1. An important issue is the relatively higher presence of ammonia as passengers in terminal building do not use the water closet very often, but they use the urinal.
2. The temperature for biological design was 37°C and 10°C in summer and winter respectively
3. The raw sewage BOD was taken as maximum of 200 mg/l and SS of 400 mg/l
4. The peak factor was taken as 1.5 as the terminal building was used almost continuously
5. The RAS was at unity and IRR from aeration tank was twice the DWF
6. HRT in anoxic tank was at 0.5 hours based on all flows through it
7. HRT in aeration tank was 18 hours based on DWF
8. Alpha value was consciously restricted to 0.6 as K_{la} was retarded in this sewage
9. Nitrification oxygen was taken as 4.8 and oxygen credit was taken as 2.86
10. Mixing air was taken as 30 cum/minute/1000 cum of aeration tank
11. The phosphorous leaving the DMF in dissolved form was allowed to go through UF and RO
12. The only solid waste from the plant is the biological sludge cake. This is used in the root zone of trees in the greenery as a soil filler/organic fertilizer
13. The quality of the blended discharge for greenery meets the requirements of pollution control
14. The plant is user friendly with PLCs and permits off-site monitoring
15. Simplified treatment scheme is shown in Figure 7.3.

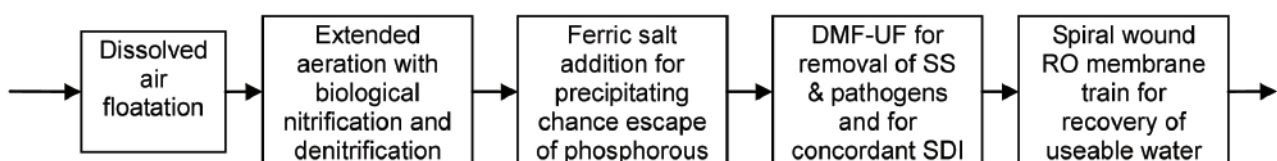

Figure 7.3 Simplified treatment scheme for IGI airport Delhi STP

7.2.2.3 Performance Results

The STP receives raw sewage from the airport terminal building and though it has higher nitrogen content as compared to domestic sewage because passengers use the urinals much more than toilets. Yet the design wetted by IIT Delhi is able to handle the biological nitrification-denitrification. The performance of the STP for raw sewage and biological treated sewage is shown in Table 7.3.

Table 7.3 Performance of the STP at DIAL for higher Nitrogen loaded sewage

No	Location	BOD	Ammonia Nitrogen	SS
1	Raw Sewage	110 to 130	45 to 53	240 to 280
2	Biological Treated sewage	8 to 10	1.5 to 3	10 to 15

The design of bioreactor is based on mixed liquor return at twice the average flow, return sludge at equal to average flow, volume of anoxic tank at 30 minutes of all flows and volume of aeration tank at 18 hours of average flow. The results reported here are at 67% of design flow

7.2.3 Reuse Plant at Mumbai International Airport Limited (MIAL), India

This is a circular SBR tank followed by hypo chlorination, pressure sand filtration and ultra filtration to produce a grade of recovered sewage free of colour, organics and odour. The treated effluent is partly used for toilet flush and the rest is put through RO membranes to recover make up grade water for HVAC.

The sewage from the terminal building is disproportionately high with urine and nitrogen as compared to normal domestic sewage and MIAL has evolved its own process design for SBR based on extended aeration.

The design for 4 MLD average flow has 2 numbers of SBR basins of each 20 m diameter and 6.5 m liquid depth, floor mounted fine bubble diffusers, floating floor level anoxic mixers, floating decanter, Alpha value as 0.85, Beta value as 0.95, F/M as 0.08, MLSS as 4500, Kg Oxygen for Kg BOD at 1.25, Kg Oxygen for Kg ammonia at 4.6, number of cycles per day as 5, alkalinity used up as 7.2 mg / mg of nitrified N, alkalinity released as 3.6 mg / mg of denitrified N and the performance at 50% of design flow as in Table 7.4.

Table 7.4 Performance of the SBR at MIAL for higher Nitrogen loaded sewage

No	Location	BOD	COD	SS	TKN	Alkalinity	TP	pH
1	Raw Sewage	102.0	230.00	55.0	42.0	190	8.0	6.95
2	SBR effluent	3.4	15.26	6.5	5.2	10	1.7	6.90

A photo of one of the SBR tanks with floating decanter and central draft tube anoxic mixer is shown in Figure 7.4.



Figure 7.4 Circular SBR based STP at MIAL with floating decanter

It shows that the heavily loaded nitrogen relative to organic matter can still be treated successfully in biological SBR at the design criteria as above and a hydraulic detention time of 24 hours in the SBR.

The final disinfection is by hypochlorite and the baffled chlorinating tank is circumventing the SBR.

7.2.4 Pointers for the Future

1. In dealing with these institutional pseudo sewage of types similar to airport terminals, the MLE process of biological nitrification-denitrification works well even when the ammonia content is higher, but then it takes about 3 months to establish the microorganisms culture with a steady dosage of micro nutrients as in Table 7.5 (overleaf). This is very important.
2. The use of extended aeration is to be preferred as conventional ASP with F/M in the range of 0.3 to 0.5 may suffer upsets when ammonia dominates in the sewage.
3. Biological phosphorous removal in upstream anaerobic reactor may or may not yield expected results in this type of sewage, where ammonia dominates the BOD at various times.
4. As long as the phosphorous is ensured to be in dissolved form it can be allowed through the UF and RO membranes, and there is no need for an exclusive phosphorous removal unit.
5. The raw sewage pump sets were of the centrifugal screw impeller in wet submersible sumps. Though it had to be imported, they were considered to be fail-proof to handle raw sewage in this sensitive location without getting choked by unexpected obstructing matters entering the sewage and may instantaneously affect the air conditioning in the terminal.

Table 7.5 Micro nutrients to be added to biological systems where microbial growth is detectable as retarded (as done at IGI Airport STP)

A	B	C	D	E	F	G	H	I	J
1	Designer to use this space for his notes								
2	Designer to use this space for his notes								
3	Designer to use this space for his notes								
4			Flow in mld	4	BOD at Inlet	300			
5		Atomic Weight	mg/mg of BOD, as element	Market Chemical	Chemical Formula	Molecular Weight	Calculation of weight of compound	mg/mg of BOD, as compound	kg needed, once a month
8	Calcium	Ca	62 x 10 power minus 4	Calcium carbonate	CaCO ₃	100	62* POWER((10),(-4))*G7/C7	0.0155	18.60
9	Cobalt	Co	13 x 10 power minus 5	Cobaltic chloride	CoCl ₂ (6H ₂ O)	238	13* POWER((10),(-5))*G8/C8	0.0005	0.64
10	Copper	Cu	15 x 10 power minus 5	Cupric sulphate	Cu(SO ₄)	160	15* POWER((10),(-5))*G9/C9	0.0004	0.45
11	Iron	Fe	12 x 10 power minus 3	Ferrous ammonium sulphate	FeSO ₄ (NH ₄) ₂ (SO ₄) (6 H ₂ O)	392	12* POWER((10),(-3))*G10/C10	0.0840	100.80
12	Magnesium	Mg	30 x 10 power minus 4	Magnesium chloride	MgCl ₂	95	30* POWER((10),(-4))*G11/C11	0.0119	14.25
13	Manganese	Mn	10 x 10 power minus 5	Manganese chloride	MnCl ₂ (4H ₂ O)	198	10* POWER((10),(-5))*G12/C12	0.0004	0.43
14	Molybdenum	Mo	43 x 10 power minus 5	Molybdic acid	MoS ₂	106	43* POWER((10),(-5))*G13/C13	0.0005	0.57
15	Potassium	K	45 x 10 power minus 4	Potassium chloride	KCl	75	45* POWER((10),(-4))*G14/C14	0.0087	10.38
16	Selenium	Se	14 x 10 power minus 10	Selenium chloride	SeCl ₄	228.825	14* POWER((10),(-4))*G15/C15	0.0041	4.87
17	Sodium	Na	5 x 10 power minus 5	Sodium chloride	NaCl	59	5* POWER((10),(-5))*G16/C16	0.0001	0.15
18	Zinc	Zn	16 x 10 power minus 5	Zinc oxide	ZnO	82	16* POWER((10),(-5))*G17/C17	0.0002	0.24

The M S Excel sheets for calculating these for continuous and batch flow systems are given as Appendix 7.1 and 7.2 in the soft copy version.

7.2.5 Reuse Plants at Chennai Petroleum Corporation Ltd. (CPCL) and Madras Fertilizers Ltd. (MFL)

These are the earliest plants designed and constructed in India between 1989 and 1991 for recovering makeup grade cooling water from Chennai city sewage. These plants however, received only the secondary treated sewage from Chennai city STPs. All the same, they still provide the biological nitrification and thereafter, high lime acidification and then RO. The RO rejects are let into the backwater zone and not directly into the marine area. The flow schematics of these plants are in Figure 7.5 and Figure 7.6. The plants treat about 12.5 mld and 17.5 mld, respectively.

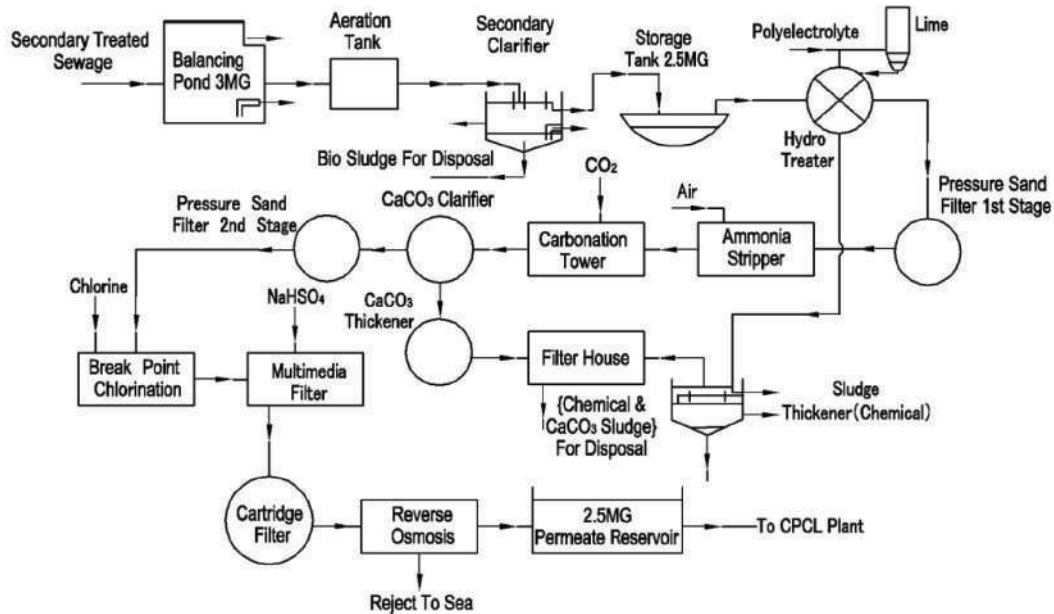

Figure 7.5 Sewage reuse schematic at M/S CPCL, Chennai

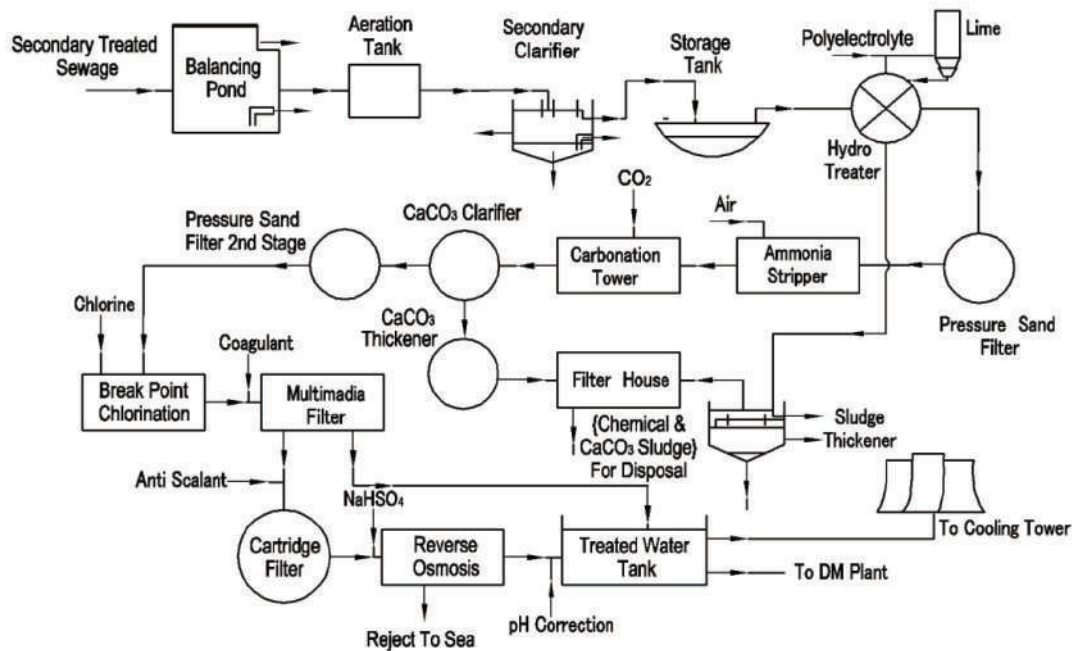

Figure 7.6 Sewage reuse schematic at M/S. MFL, Chennai

7.2.6 Sewage Reuse Plant at M/S Rashtriya Chemicals and Fertilizers, Mumbai

This is a plant receiving raw sewage and recovering cooling grade makeup water. Its flow scheme is shown in Figure 7.7.

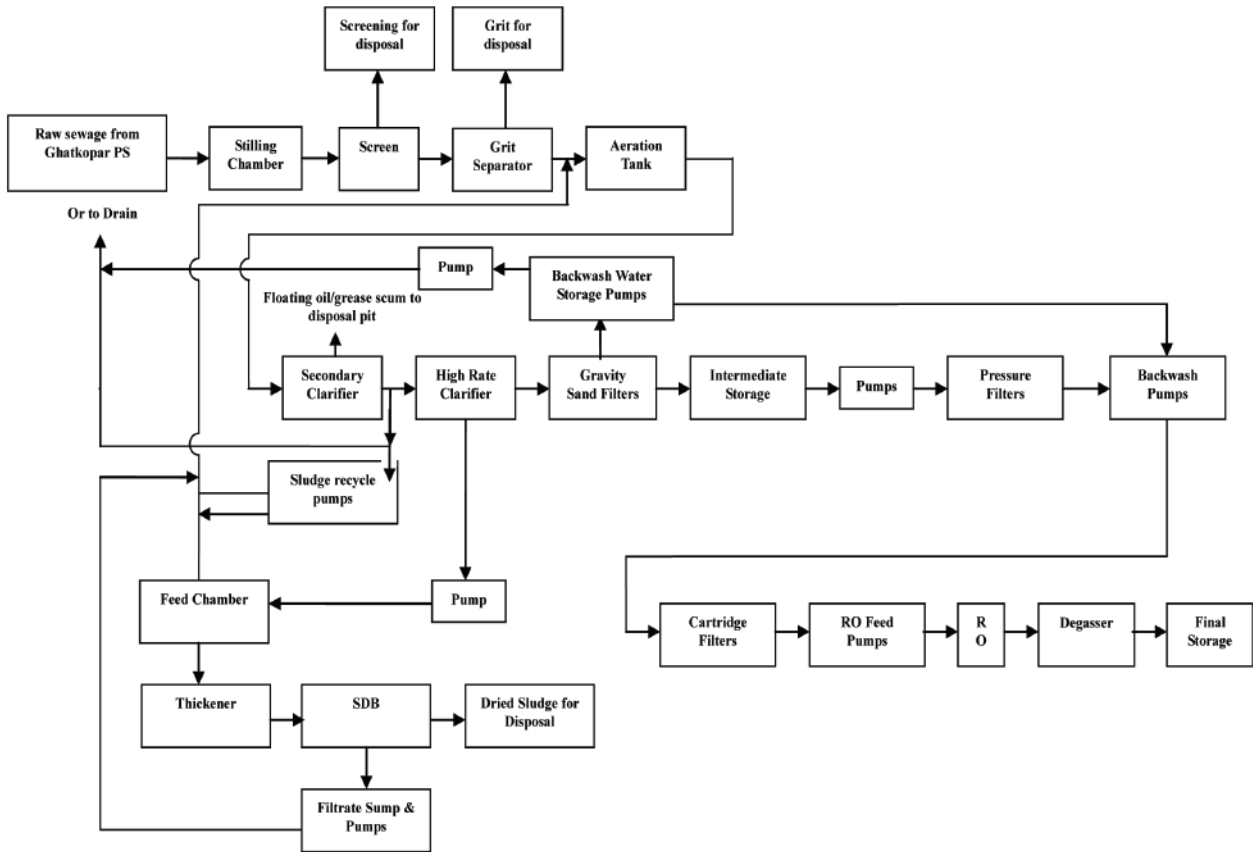

Figure 7.7 Sewage reuse schematic at M/S RCF, Mumbai

The 23 mld STP commissioned in the year 2000 treats a complex municipal sewage heavily contaminated with various industrial wastes. Though originally conceived with a single step chemical treatment after biological treatment, subsequently some additional treatment steps like use of UF became necessary in order to improve the quality of the water reaching the RO system (keeping the silt density index, SDI < 3.0) owing to the more polluted nature of the influent sewage.

This is a classic scenario of the need to design the treatment process to be flexible for impacts by industrial effluents in the raw sewage and especially the trace metals and heavy metals. These are possibly better served by the high lime and neutralization than a single stage chemical treatment.

7.2.7 Bengaluru, India

The Bengaluru city freshwater crisis is so high that its present quota of freshwater from the river Cauvery will get exhausted soon and the demand of the city may overtake the supply. It was considered to study a pilot model of the Singapore NEWater for indirect augmentation by advanced treatment of secondary facilities.

The proposal was to add biological nitrification denitrification and tertiary treatment in chemical precipitation of phosphorous and cascade the treated water over 20 km and a 65 m fall in a river course.

The runoff will be intercepted and subjected to conventional water treatment with clariflocculators and rapid sand filters and then pumped back through the 65 m rise by a pipeline with chlorination. Thereafter, it will be put through dual media and activated carbon filtration followed by UF and RO membranes.

The idea was to ensure removal of endocrine disruptor chemicals (EDCs) by activated carbon and enteroviruses by ultra filtration membranes. The RO will bring back the TDS to the freshwater levels and ensure additional removals of virus if any. The RO rejects will be put through accelerated evaporation spray ponds.

The RO permeate will be let into a freshwater river course to travel about 8 km before it enters a freshwater impoundment. The detention period calculated by the volume of the impoundment and the volume of renovated water will be close to two years to bring out limnological equilibrium of the blended water through the seasons before drawal into a conventional water treatment plant (WTP) and chlorination before being blended with the freshwater supplies.

The sludge from the WTP will be stored in secure landfills subject to further studies on soil sludge immobilization for making paver blocks for walkways and compound walls.

The volume of such indirect augmentation will become close to 140 mld compared to the availability of treated sewage of 1500 mld by the time the project could be completed after due public hearing, subject to which, the project has been accorded sanction by the JnNURM as a pilot project. Understandably, such projects will take time to materialize.

The schematic of this treatment is shown in Figure 7.8 (overleaf).

A subsequent thinking is to explore the possibility of a dedicated cascade channel along the 20 km river course if the river purification gets into time delays by the time these two are to dovetail in the future. The cost of the renovation was Rs.15.6 per kilo litre of water produced and compares favourably with the cost of freshwater production at Rs.14.2 per kilo litre.

At this time, this project proposal is a statement of capability to formulate a technically feasible and financially viable project and of course the biggest challenge of going through and obtaining public acceptance is understandably a long drawn out process.

The treatment sequence proposed in this project is shown in Table 7.6 and is compared with the treatment sequence used in other similar known installations elsewhere.

7.2.8 Karnal, India

The Indian Agricultural Research Institute at Karnal, India has carried out work on sewage farming and has recommended that growing tree on ridges 1 m wide and 50 cm high with even untreated sewage in furrows can still be considered.

Table 7.6 Comparison of treatment barriers used in projects in the World for indirect potable reuse of treated sewage

No.	Location	A	B	C	D	E	F	G	H	I	J	K	L	M	N	O
1	Windhoek, Namibia	✓						✓	✓	✓					✓	✓
2	Occoquan, USA				✓	✓		✓								
3	Singapore	✓									✓	✓			✓	✓
4	V. Valley, Bangalore	✓	✓	✓	(*)	NR-1	✓	✓	✓	✓	✓	NR-2	✓	✓	✓	✓

Explanatory Notes of Treatment Components

	F	G	H	I	J	K	L	M	N	O
A	Tertiary treatment including removal of nitrogen and phosphorous besides organics		Sand Filtration to hold back escaping suspended solids and improving carry overs							R O membrane filtration for reducing the hardness of recovered water as needed
B	18 Km travel of tertiary treated sewage in river course for natural self rejuvenation		Chlorination in pumping main with 6 hours contact in booster doses en route							7 km of travel of pathogen free water in natural river valley for naturalization
C	Storage in pick up weir for disinfection by sun rays & natural aquatic equilibrium		Activated Carbon Treatment for removing trace organics and chance THMs							450 days in open reservoir for disinfection by sun rays & natural aquatic equilibrium
D	High Lime for inactivation of pathogenic organisms & heavy metal precipitation		Ultra Filtration for removal of enteric pathogens and specifically viruses							Conventional water treatment for floating matters and hardness reduction
E	Two stage carbonation to remove the increased TDS due to high Lime treatment		Micro filtration for removal of upto bacteria alone (but not viruses)							Residual chlorination of treated water to ensure detection of sterility

(*) Pathogen removal in high lime in Occoquan is instead met by UF in the proposed project and avoids problems of chemical sludge.
 NR-1 The 2 stage carbonation as practiced in Occoquan is not required in the proposed project as the pH is not raised in the treatment.
 NR-2 Hardness Removal is achieved in the Lime water treatment process in the final stage in the chain of treatment.
 Source: Bangalore Water Supply and Sewerage Board, 2008
 The treatment sequence adopted in the V. Valley scheme at Bangalore is more rugged and has multiple layers of sequential safety. It is too early to embark on this till the results of the Bengaluru piloting are validated.

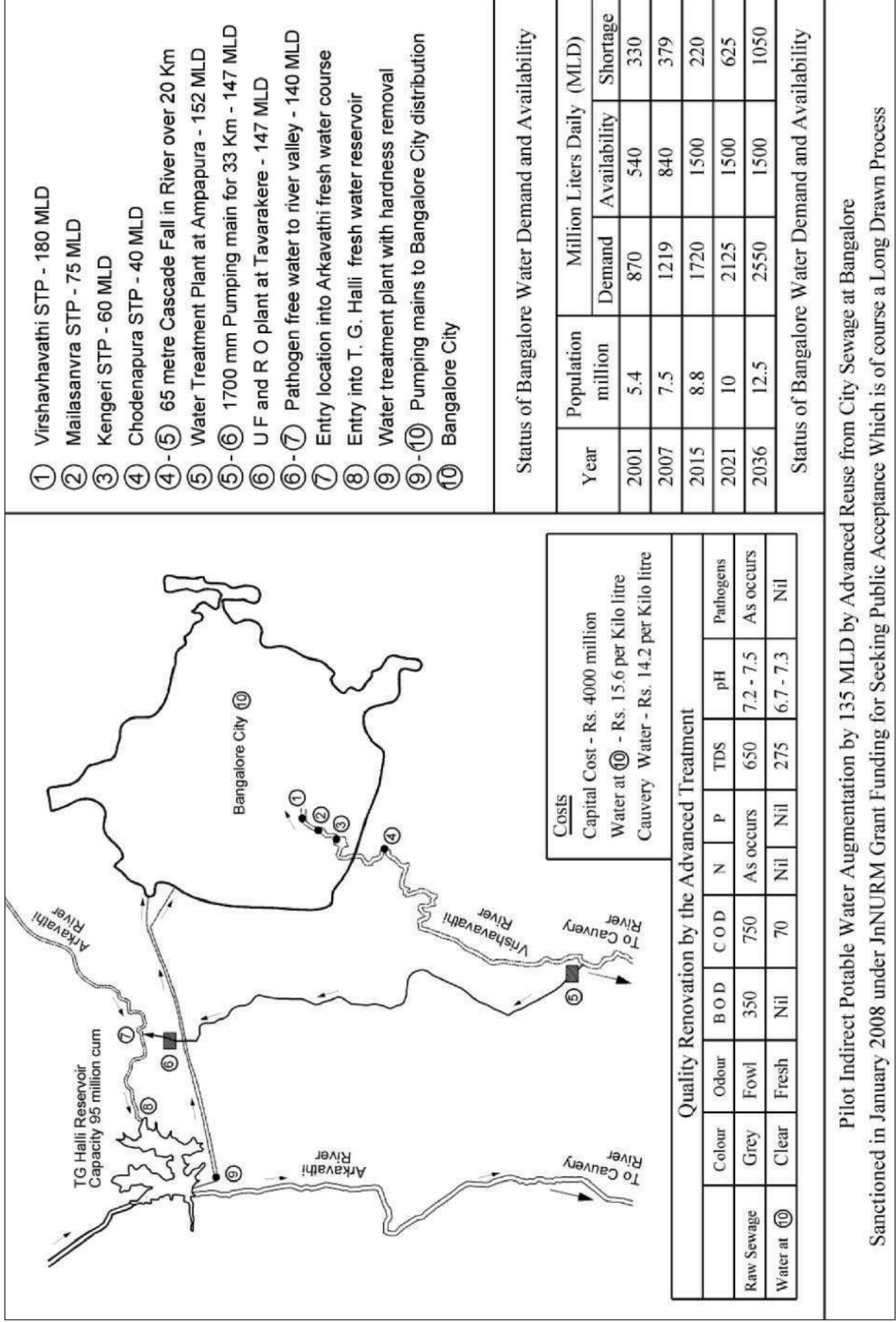
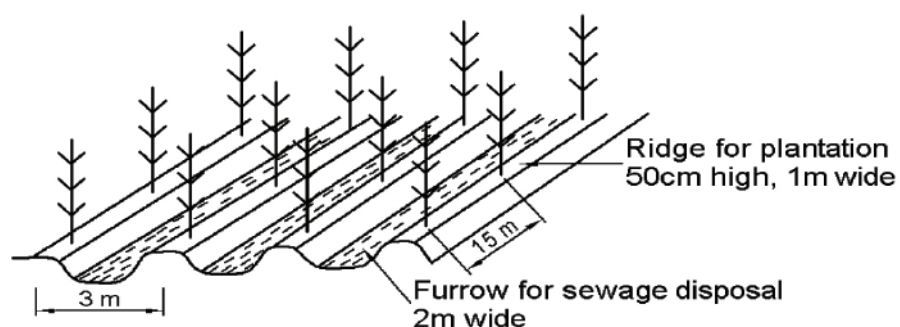

Figure 7.8 Schematic of treatment for reuse in Bangalore

The amount of the sewage / effluents to be disposed of depends upon the age, type of plants, climatic conditions, soil texture and quality of effluents. The total discharge of effluent is so regulated that it is consumed within 12-18 hours and there is no standing water left in the trenches. Through this technique, it is possible to dispose of 0.3 to 1.0 ML of effluent per day per hectare. This technique utilizes the entire biomass as living filter for supplying nutrients to soil and plant; irrigation renovates the effluent for atmospheric re-charge and ground storage. Further, as forest plants are to be used for fuel wood, timber or pulp, there is no chance of pathogens, heavy metals and organic compounds to enter into the human food chain system, a point that is a limiting factor when vegetables or other crops are grown with sewage.

Though most of the plants are suitable for utilizing the effluents, yet, those tree species which are fast growing can transpire high amounts of water and are able to withstand high moisture content in the root environment are most suitable for such purposes. Eucalyptus is one such species, which has the capacity to transpire large amounts of water and remains active throughout the year. Other species suitable for this purpose are poplar and leucaena. Out of these three species, eucalyptus seems to be the best choice as poplar remains dormant in winter thus, cannot bio-drain effluent during winter months. However, if area is available and the volume of effluent is small, a combination of poplar and eucalyptus is the best propagation.

This technology for sewage water use is relatively cheap and no major capital is involved. The expenditure of adopting this technology involves cost of making ridges, cost of plantation and their care. This system generates gross returns from the sale of fuel wood. The sludge accumulating in the furrows along with the decaying forest litter can be exploited as an additional source of revenue. As the sewage water itself provides nutrients and irrigation ameliorates the sodic soil by lowering the pH, relatively unfertile wastelands can be used for this purpose. This technology is economically viable as it involves only the cost of water conveyance from source to fields for irrigation and does not require highly skilled personnel as well. The institute mentions this technology to be the most appropriate and economical viable proposition for the rural areas as this technology is used to raise forestry, which would aid in restoring the environment and to generate biomass. The irrigation method is shown in Figure 7.9.



Source: CSSRI, Karnal

Figure 7.9 Irrigation method for sewage fed tree plantation as per Karnal Institute

7.2.9 Mudiali (Kolkata), India

About 400 hectares of fish ponds are in use at Kolkata. Individual ponds are about 40 hectares in area and have five distinct phases covering pond preparation, primary fertilization, fish stocking, secondary fertilization and fish harvesting. The photosynthetic activity in the pond is the basis for biological purification of the sewage. Once the water turns completely green, stocking of fish is initiated and repeated several times in a year. Catla (Catlacatla), Rohu (Labeo rohita), Mrigal (Cirrhinus Mrigala) and Bata (Labeo Bata) are mainly grown in bulk for the stock consisting of mrigal. Exotic fish like Silver Carp (Hypophthalmichthys molitrix), Grass Carp (Ctenopharyngodon idella) and common carp (Cyprinus carpio) are stocked as a small percentage. However, the popularity of tilapias (*Oreochromis niloticus* and *O. mossambicus*) is increasing. Sewage is drawn at 1 to 10% of the total volume of water in the pond at intervals throughout the culture period and thereafter, continuous inflow and outflow are maintained by allowing the same level of water to flow out of the pond. Aquatic weeds like water hyacinth are grown along pond dikes of larger ponds to break waves and prevent damage to dikes. In addition, these weeded areas, provide shelter to fish when the temperature rises, prevent poaching of fishes to some degree and most importantly serve as filters to extract nutrients and metals from the system. When these weeds grow in excess, they are periodically harvested and decomposed in the pond to enhance fertility of water. In sewage fed farms, bacterial diseases are not common. Even when there were problems with Epizootic Ulcerative Disease (EUS) in recent years with carps in other areas, carps in these sewage-fed ponds remained uninfected. However, parasitic infections by *Lernea* (anchor worm) and *Argulus* are common and there is a need to develop techniques for the control of this problem. This has been partly attributed to the good nutrition obtained from the rich plankton growth in ponds. Figure 7.10 shows the procedures in tending to the ponds as a routine and Figure 7.11 and Figure 7.12 shows the ponds and the catch.

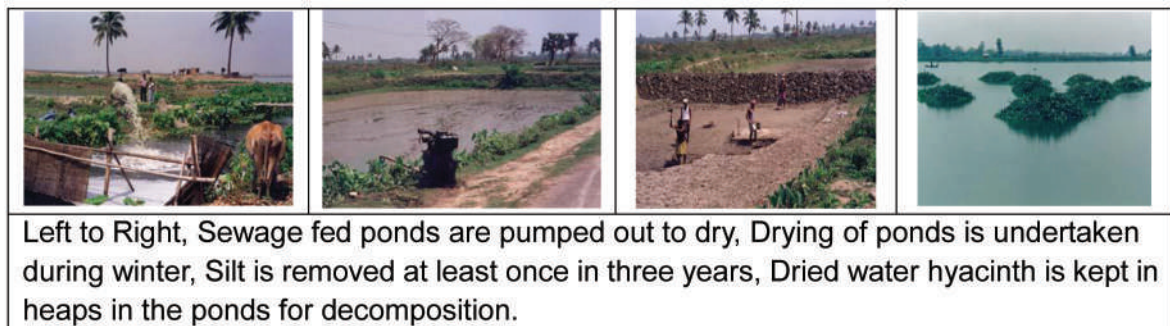

Figure 7.10 Stages of fish farming



Figure 7.11 Ponds and high rise buildings



Figure 7.12 Full grown & fresh harvested fish

Studies on infections carried by the fish revealed that though there were stray concerns, the fact that all fish is well cooked before eating negates any risk of ingestion. The farm is a staple supplier of edible fish to Kolkata and thus, the demand is steady throughout the year.

7.2.10 Orange County California, USA

Water scarcity is a major issue in Southern California. A scarcity of freshwater resources, combined with the threat of saline ingress from the Pacific Ocean, create an urgent need for alternative resources. As a result, an ambitious water reclamation project, “Water Factory 21” (WF21)-the first groundwater recharge project allowed in California, was started in 1971 by the Orange County Water district (OCWD). Its purpose was to create a seawater intrusion barrier by injecting a 50:50 blend of reclaimed water and other water (deep well water or imported freshwater from neighbouring river basins like Colorado River) in infiltration facilities. The recycled water was pumped to spreading basins and followed the same natural path as rainwater runoff. The water produced was of very high quality due to a multi-barrier process involving multimedia filtration. In 1977, reverse osmosis treatment (RO) was added. Considering the consistent high quality of water produced, the ratio of reclaimed water was progressively increased, and in 1991 the WF21 obtained a permit to inject from 67% to 100% reclaimed water. The plant produced 57,000 m³/d of reclaimed water.

In 1997, the OCWD launched a new project, using membrane technology: the Groundwater Replenishment System (GWRS). As a result, WF21 was shut down to allow the construction of an improved and larger high-tech purification plant, called the Advanced Water Purification Facility (AWPF). The new plant started operation in January 2008, which used a multi-barrier process involving microfiltration (MF), RO and UV and hydrogen peroxide disinfection, and produced up to 265,000 m³/d of near-distilled quality water. Of this, approximately 132,500 m³/d is pumped into injection wells to create a seawater intrusion barrier. Remaining 132,500 m³/d is pumped to OCWD percolation basins in Anaheim where the GWRS water naturally filters through sand and gravel to the deep aquifers of the groundwater basin as in Figure 7.13 and Figure 7.14 (overleaf).

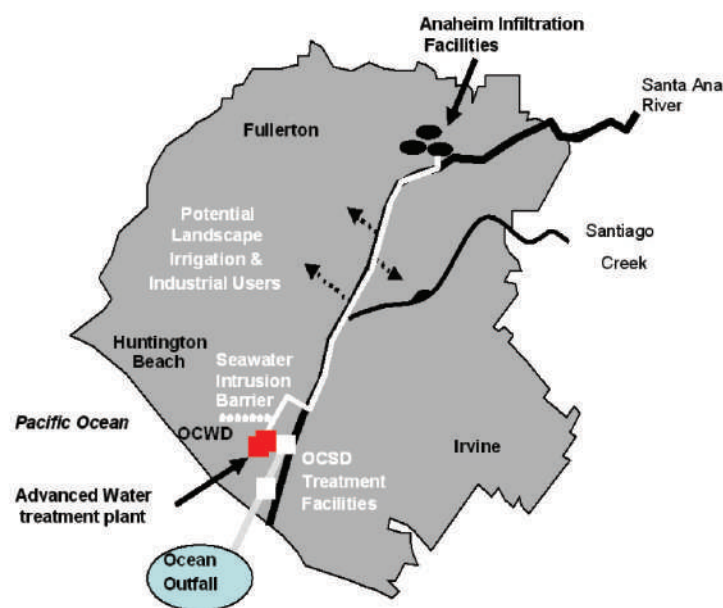

Figure 7.13 Relative locations of treatment plant and infiltration facilities at Anaheim



Source:OCWD home page

Figure 7.14 Purified water from the GWRS is piped to OCWD's percolation ponds in Anaheim, California

The AWPf has many advantages over other solutions for water production, especially compared to the old WF21 plant: the MF stage occupies less space, requires less maintenance and improves the performance of the downstream process compared to the conventional pre-treatment used at WF21. This project was accepted after a cost-benefit analysis that showed that the construction of the AWPf was the most cost-effective solution. The reclaimed water was expected to be produced for approximately $0.39\$/\text{m}^3$, whereas desalinated water would cost at least twice as much. Moreover, the cost of the GWRS is less than the cost of treated imported water, and a study showed that reclaimed water was 50% less energy-consuming than water importation.

The main purpose of the GWRS remains the recharge of the aquifer: it will be able to supply about 22% of the water needed to recharge the Orange County groundwater basin in the year 2020, which is forecast to reach over 500 million m^3/y . Groundwater recharge will limit seawater intrusion and thus, improve regional water quality by lowering salinity in the water supply, especially since this high quality water will contain less dissolved solids than imported water from the Colorado River. Furthermore, the GWRS will be used to reduce peak-flow under wet weather conditions and the excess flow can be diverted through the GWRS. As a result, there is no immediate need for a new ocean outfall, which is beneficial both from an economic and environmental point of view (Mediterranean Wastewater Reuse Working Group, 2007).

7.2.11 Tokyo Metropolitan, Japan

In Tokyo, municipal sewerage service covers almost the whole area ($2,187\text{km}^2$) and 5.5 million m^3 sewage is treated in a day. Tokyo Metropolitan Government (TMG) is now promoting the reuse of wastewater for toilet-flushing by area-wide water recycling system. In this system, the secondary effluent of municipal sewer system is treated by tertiary or advanced process and reclaimed water is supplied to buildings for toilet-flushing use.

In 1984, a model business of area-wide water recycling system was started, which supplied reclaimed wastewater to commercial buildings in Shinjuku for toilet-flushing use (Figure 7.15).

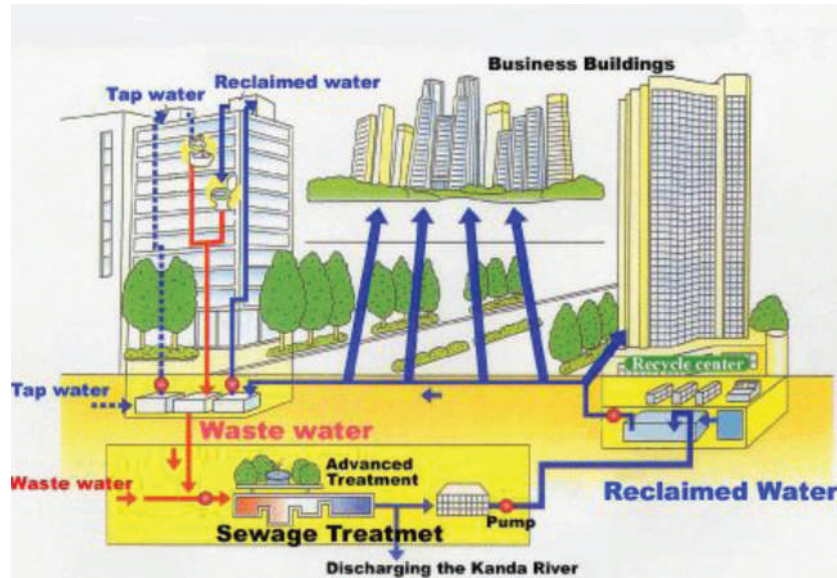

Source: Tokyo Metropolitan Government webpage

Figure 7.15 Schematic of recycling system in Shinjuku

This project is the first milestone of area-wide water recycling system in Japan. Now, 4,000 m³ of secondary effluent is treated by rapid sand-filtration system in Ochiai Wastewater Treatment Plant and supplied to 28 high-rise buildings. This type of area-wide recycling system is continuously introduced into bay side redeveloped area. In 2006, approximately 3 million m³ of reclaimed water (daily average amount was 8,400 m³) was produced at three STP and supplied to 129 buildings in five areas and two more areas will be added into supply plan. To promote this type of water reuse further, TMG asks owners of buildings to install dual pipe systems when they construct large buildings having a certain scale.

In addition, Ochiai STP also discharged tertiary treated wastewater by rapid sand-filtration system to urban rivers (Meguro River) to the amount of 110,000 m³/day in 2005. Reclaimed water is also distributed to artificial streams or ponds in adjacent parks (after RO treatment), industries, incineration plants of domestic waste, a railway company, and tanks for fire fighting use. In order to improve colour and odour of reclaimed water, TMG had developed a reclamation system with "Ozone-resistant membrane". This system is composed of pre-ozonation, bio-filtration, ozonation and micro-filtration after secondary treatment (*Yamada, et al*).

7.2.12 Restoration of Meguro River, Japan

The Meguro River, which flows through a residential area in Tokyo, had been abandoned by residents due to the decreasing flow of water and increasing pollution with an unpleasant colour and odour due to ever increasing urbanization since the Meiji Period. In order to restore river water quality and biodiversity, the TMG used highly treated effluent from the Ochiai Water Reclamation Centre to discharge into the river. Located very close to the sub-centre of the Shinjuku area, the Ochiai Water Reclamation Centre is environment-friendly and thoroughly controlled as a water reclamation centre surrounded by residential districts.

The treatment area includes most of Nakano-ward and a part of Shijuku-ward, Setagaya-ward, Shibuya-ward, Suginami-ward, Toshima-ward and Nerima-ward, totalling 3,506 ha in area. The treatment units of the reclamation centre include grit chamber and primary sedimentation tank as preliminary and primary treatment, activated sludge process (ASP) as secondary treatment and A2O process for nutrient removal, sand and membrane filtration and UV radiation as tertiary treatment. The schematic of the sequence of various treatment units of the Ochiai Water Reclamation Centre is presented in Figure 7.16.

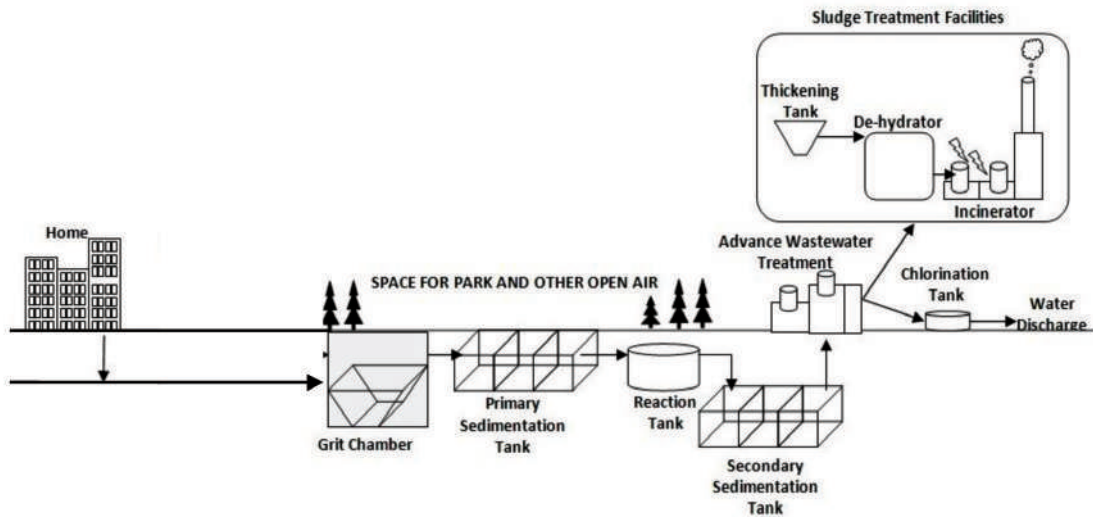

Figure 7.16 Sequence of treatment units in Ochiai Water Reclamation Facility for wastewater reclamation

The highly treated water (Table 7.7) is discharged for restoration of streams in Meguro River and other two rivers, which nearly dried up in the southern downtown area of Tokyo.

Table 7.7 Average influent and effluent water quality for the Ochiai Water Reclamation Facility

Parameters	Intake water		Discharge Water	Regional water quality standards
	Low stage	High stage	High stage	
BOD ₅ (mg/l)	220	190	1	25 or below
COD (mg/l)	92	92	7	-
TN (mg/l)	31.7	27.9	11.5	30 or below
TP (mg/l)	3.7	3.0	1.5	3.0 or below

Source: Tokyo Metropolitan Government

Some parts of the treated water is used effectively for flushing water in toilet in buildings of Nishi-shinjuku and Nakano-sakaue districts. The generated sludge is pumped through pressure pipelines to Tobu sludge plant for treatment. With the drastic improvement in water volume and quality, various living species have returned to the Meguro River. The condition of the Meguro River before and after restoration is shown in Figure 7.17 (overleaf).



Source:Tokyo Metropolitan Government

Figure 7.17 Condition of Meguro River (a) before and (b) after the restoration using reclaimed wastewater

Many insects and small animal populations have been re-established, and fish such as Japanese trout, striped mullets and gobies also returned to the river after the introduction of highly treated water. The biodiversity and environmental amenities have thus, been restored effectively with wastewater reuse.

7.2.13 Road Washing and Subway Coach Cleaning, Republic of Korea

Around 16.07 billion tons of treated water is produced annually from 4 sewage treatment plants (Jungnang, Nanji, Tancheon, Seonam) in Seoul. Out of this amount, around 48.7 million tons are reused and Seoul is planning further to extend the scope of reusing as in Figure 7.18.



Source:Tokyo Metropolitan Government, Bureau of Sewerage webpage

Figure 7.18 Water from Jungnang sewage treatment plant reused for road cleaning

Around 16,546,000 tons of treated water from Jungnang sewage treatment plant is used as cleaning or wiping water every year within the plant. About 19,000 tons is provided to be used for cleaning roads outside the plant. Every year 82,000 tons of water from the plant is used at nearby subway coach depot for cleaning of coaches as in Figure 7.19.



Source: Tokyo Metropolitan Government, Bureau of Sewerage webpage

Figure 7.19 Highly treated sewage used at subway coach depot for cleaning

7.2.14 Ground Cooling, Japan

In Japan, reclaimed wastewater has been recycled widely for non-potable urban applications such as toilet flushing, landscape irrigation, cleaning roads and snow melting. The government policy of “Sewerage Vision 2100” suggested creating sound water cycles by using reclaimed wastewater effectively. In this respect, attention has focused on a new way of using reclaimed wastewater; sprinkling it on roads for heat island mitigation as in Figure 7.20 (overleaf).

The term “heat island” refers to urban air and surface temperatures that are higher than nearby rural areas. Heatstroke is one of the impacts caused by the heat island. “The Policy Framework to Reduce Urban Heat Island Effect” was set in March 2004 including countermeasures such as: reduction of anthropogenic heat; urban surface improvement to regain natural cooling effect of soil and plant evapotranspiration; improvement of urban structure with green and water network to reduce the heat from the city; and promotion of energy saving life. Sprinkling reclaimed wastewater or other unused water on roads in urban areas is one of the means of improving urban surface in summer.

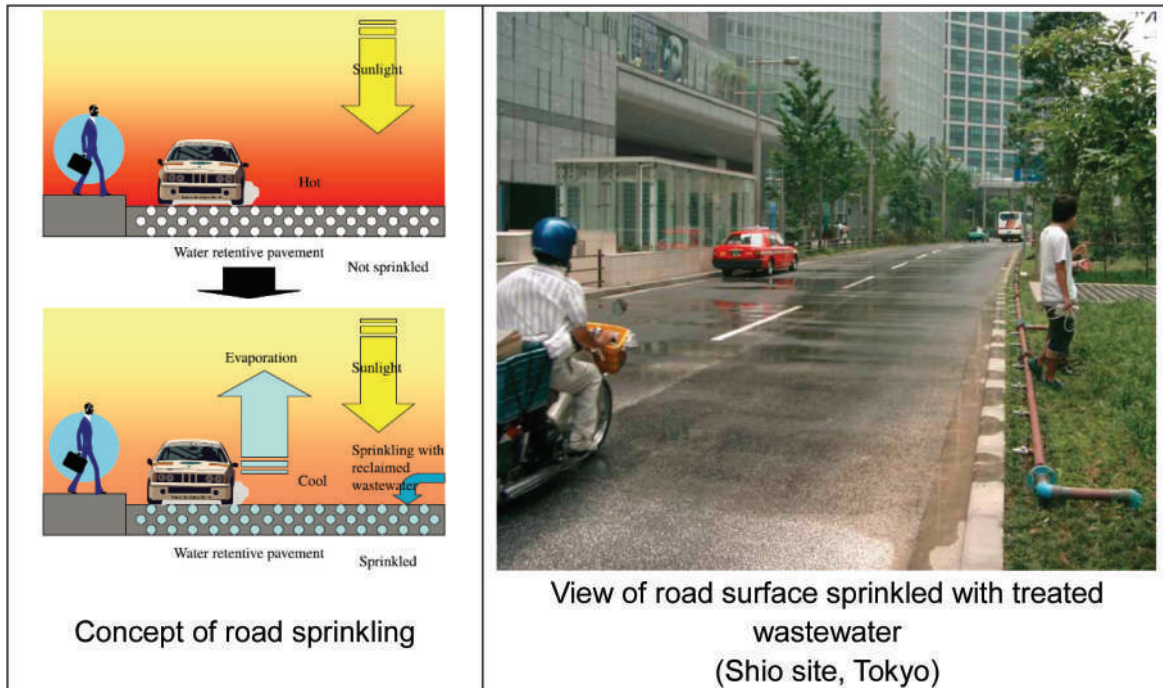

Source: Yamagata et al., 2008

Figure 7.20 Road sprinkling with treated wastewater

As a pioneer, treated wastewater is sprinkled on the water retentive pavement that can store water inside paving material at Shiodome Land Readjustment District (Shio Site) in Tokyo. Research projects have been carried out there on the heat island mitigation by sprinkling reclaimed wastewater on roads. Treated wastewater from plants using advanced processes such as biological filtration, ozonation, or microfiltration, is used for spreading on the roads (Yamagata, et al, 2008).

It was observed that sprinkling treated wastewater on water retentive pavement decreased the road surface temperature by 8 degrees during the daytime and by 3 degrees at night and the road surface temperature was decreased to same level as that on planting zones. Especially, the decrease of road surface temperature continued all the night by sprinkling water in the evening.

7.2.15 Singapore NEWater

The island of Singapore suffers from serious issues of water scarcity, as Singapore's domestic resources only meet about 50% of its needs and purchases water from nearby Malaysia. Water reuse has always been an important component of Singapore's water management: reuse of tertiary quality effluents for industrial activities began in the early 1970s. Nowadays, water recycling is part of the government's "Four Taps Strategy" to ensure a sustainable water supply by diversifying its water resources: imported Malaysian water, seawater desalination, collection and treatment of local surface run-off and water reuse.

Singapore's Public Utility Board (PUB) manages the nation's water resources. In 1998, the PUB launched a joint initiative to determine the suitability of reclaimed water, which underwent advanced treatment processes of multi-barriers filtration and ultraviolet (UV) disinfection as a source of raw water for drinking water production.

A 10,000 m³/d demonstration plant was built in 2000, and its successful performance resulted in the launch of the NEWater project. At that time, two full-scale plants were launched within one week of each other: Kranji (40,000 m³/d) and Bedok (32,000 m³/d) as in Figure 7.21.



Source: Mediterranean Wastewater Reuse Working Group, 2007

Figure 7.21 Map showing location of NEWater facilities in Singapore

In 2001, PUB officially named “NEWater” the recycled water produced by the reclamation plants. In 2003, potable and non-potable production of NEWater was officially opened with direct supply from three NEWater plants at Bedok and Kranji with a combined capacity of 72,000 m³/day. In 2004 and 2007, two new reclamation plants were opened. They are Seletar (24,000 m³/d) and Ulu Pandan (116,000 m³/d) respectively.

Most of the NEWater is used for non-potable applications in the wafer fabrication/ microelectronics industry. Concerning indirect potable reuse (IPR) (through recharge of the freshwater catchment reservoirs) it consists currently of 1% of the total volume of water consumed daily. The NEWater produced is blended with the raw water in the surface reservoirs. Then this water undergoes conventional water treatment to produce drinking water. Only a small part (1%) of tap water contains diluted, blended and treated NEWater. Two programs have also been undertaken to assess the quality of water being produced. They are Sampling and Monitoring Program (SAMP) and Health Effects Testing Program (HETP).

7.3 GUIDING PRINCIPLES FOR INDIA

Though the possibilities of using treated sewage for various uses in other parts of the world are inspirational, still a blanket adoption in India needs to be tempered with local factors of affordability, sustainability and above all public acceptance. Moreover, though there are exotic quality guidelines brought out for specific applications, the inheritance of these may not be pragmatic in that some of the parameters mentioned there are not easily decipherable leave alone being carried out.

Moreover, each situation needs to be evaluated on its own and beyond the secondary treatment, all technologies are necessity driven are discussed hereunder and much less the treatment chain is utility purpose driven. As such, there is a need to have a set of guidelines for the mentioned reuse prospects.

7.3.1 Agriculture

7.3.1.1 Key Principles

Following key principles should be paid attention before deciding use of treated sewage for agriculture:

- a) Being an agrarian economy, this is a very compelling use for India, but should never be used for edible crops or plants that produce millets, etc.
- b) The use of untreated sewage for whatever form of agriculture leads to a situation where the treated sewage entering another basin from its parental basin creates issues of water rights and as far as possible, inter basin transfer of such reuse are not to be encouraged
- c) Agricultural use being more pertinent in rural settings, local sewage is best treated with stabilization ponds followed by maturation ponds
- d) Rotational crop pattern shall be investigated for an all the year round utilization and designed such that the runoff of treated sewage in summer is minimized
- e) As far as possible, manual direct handling shall be avoided and field channels are better suited as compared to sophisticated drip irrigation etc
- f) The discharge standards for disposal on land is prescribed by the MoEF are mentioned in Chapter 5 of Part A manual
- g) Specific limitations on individual parameters when the treated sewage is to be considered for irrigation are addressed herein

The quality of water for irrigation is determined by the effects of its constituents both on the crop and the soil. The deleterious effects of the constituents of the irrigation water on plant growth can result from

- (i) direct osmotic effects of salts in preventing water uptake by plants,
- (ii) direct chemical effects upon the metabolic reactions in the plant and
- (iii) any indirect effect through changes in soil structure permeability and aeration.

The suitability of the irrigation water is judged on the basis of soil properties, quality of irrigation water and salt tolerance behaviour of the crop grown in a particular climate. The water quality ratings along with the specific soil conditions recommended are shown in Table 7-8 (overleaf).

These limits apply to the situations where the groundwater table is always at 1.5 m below the ground level. The values have to be reduced by half, if the water table comes up to the root zone.

Table 7.8 Water quality ratings

Nature of soil	Crop to be grown	Permissible limit of Electrical Conductivity of water for safe irrigation (micro-mhos/cm)
Deep black soils and alluvial soils having a clay content more than 30%	Semi-Tolerant	1,500
Fairly to moderately well drained soils	Tolerant	2,000
Heavy textured soils having a clay content of 20-30%	Semi-Tolerant	2,000
Soils well drained internally and having good surface drainage system	Tolerant	4,000
Medium textured soils having a clay content of 10-20%	Semi-Tolerant	4,000
Soils very well drained internally and having good surface drainage system	Tolerant	6,000
Light textured soils having a clay content of less than 10%	Semi-Tolerant	6,000
Soils having excellent internal and surface drainage	Tolerant	8,000

Source: CPHEEO, 1993

If the soils have impeded internal drainage either on account of presence of hard stratum, unusually high amounts of clay or other morphologic reasons, the limit of water quality should again be deliberately reduced to half. In cases where canal irrigation exists during the lean period, treated sewage of higher electrical conductivity could be used.

7.3.1.2 Osmotic Effects

When water is applied for cultivation on land, some of it may run off as surface flow or be lost by direct surface evaporation, while the remainder can be infiltrated into the soil. Of the infiltrated water, a part of it can be for consumptive use, and part is held by the soil for subsequent evapotranspiration and the remaining surplus percolates or moves internally through the soil. The water retained in the soil is known as the 'soil solution' and tends to become more concentrated with dissolved constituents as plants take relatively purer water. An excessive concentration of salts in the soil solution prevents water uptake by plants. Table 7-8 mentions the permissible levels of electrical conductivity (EC) and hence, total salts in water for safe irrigation in the four types of soils. It may be pointed out that good drainage of the soils may be a more important factor for crop growth than the EC of the irrigation water, as leaching of soils results in maintaining a low level of salt in soil solution in the root zone.

7.3.1.3 Toxic Effects

Individual ions in irrigation water may have toxic effects on plant growth. Table 7-9 lists some of the known toxic elements and their permissible concentration in irrigation waters when continuously applied on all soils and also when used on fine texture soils for short terms.

Table 7.9 Maximum permissible concentration of toxic elements in irrigation waters

Element		Maximum permissible concentration (mg/l)	
		On all soils in continuous use or acidic soils	For short term use of textured alkaline soils
Aluminium	Al	1.0	20.0
Arsenic	As	0.1	2.0
Beryllium	Be	0.1	0.5
Boron	B	0.5	1.0
Cadmium	Cd	0.01	0.05
Chromium	Cr	0.10	1.0
Cobalt	Co	0.05	5.0
Copper	Cu	0.2	5.0
Iron	Fe	5.0	20.0
Lead	Pb	5.0	10.0
Lithium	Li	2.5	2.5
Manganese	Mn	0.20	10.0
Molybdenum	Mo	0.01	0.01
Nickel	Ni	0.20	2.0
Selenium	Se	0.005	0.01
Vanadium	V	0.10	1.0
Zinc	Zn	2.0	10.0

Source: Environment Studies Board, 1973, CPHEEO, 1993

Many of these are also essential for plant growth. The suggested values for major inorganic constituents in water applied to land are presented in Table 7.10.

Table 7.11 presents the suggested limits for salinity in irrigation waters.

Table 7.10 Suggested values for major inorganic constituents in water applied to the land

Problem and Related Constituent	Impact on the land		
	No problem	increasing Problem	Severe
Salinity			
Conductivity of Irrigation water (millimhos/cm)	< 0.75	0.75 – 3.00	> 3.00
Permeability			
Conductivity of Irrigation water (millimhos/cm)	< 0.50	< 0.50	< 0.20
Sodium absorption ratio (SAR)	< 18.0	18.0 - 26.0	26.0
Specific Ion Toxicity (from root absorption)			
Residual Sodium Carbonate (RSC), (meq/l)	< 1.25	1.25 – 2.5	> 2.5
Sodium (Na, %)	(A)	(A)	(A)
Chloride, meq/l	(B)	(B)	(B)
Chloride, mg/l	< 142.00	142.00 - 355.00	> 355.00
Boron, mg/l	< 1	1– 4	> 4
Specific Ion Toxicity (from foliar absorption, sprinklers)			
Sodium (Na, %)	(C) < 40	(C) 40 - 60	(C) > 60
Chloride, meq/l	< 250	250 – 1,000	> 1,000
Miscellaneous			
NO ₃ (mg/l) for sensitive crops	(D)	(D)	(D)
pH	6.5 – 8.5		

Source: IS: 10500

Note :

- (A) – No guidelines laid down, but increasing concentration affects soil structure and permeability
- (B) - No guidelines laid down, but may have direct toxic effect with sodium
- (C) – No guidelines laid down, but these are recommended values
- (D) – No guidelines – it is an essential plant nutrient, but excess may delay the maturity of seed growth in some plants.

Table 7.11 Suggested limits for salinity in irrigation waters

Crop Response	TDS mg/L	EC, mhos/cm
No detrimental effects will usually be noticed	500	0.75
Can have detrimental effect on sensitive crops	500 – 1,000	0.75 - 1.50
May have adverse effects on many crops	1,000 – 2,000	1.50 - 3.00
Can be used for salt tolerant plants on permeable soils with careful management practices	2,000 – 5,000	3.00 - 7.50

Source: CPHEEO, 1993

7.3.1.4 Sodium Hazard

In most normal soils, calcium and magnesium are the principal cations held by the soil in replaceable or exchangeable form. Sodium tends to replace calcium and magnesium when continuously applied through irrigation water. An increase of exchangeable sodium in the soil causes deflocculating of soil particles and promotes compaction, thereby impairing soil porosity and the water and air relations of plants.

The sodium hazard of irrigation water is commonly expressed either in terms of percent soluble sodium (PSS) or sodium adsorption ratio (SAR).

$$PSS = \frac{100 \times Na^+}{Na^+ + Ca^{++} + Mg^{++} + K^+}$$

or

$$= \frac{100 \times Na^+}{(Total\ Cations)} \quad (7.1)$$

and

$$SAR = \frac{Na^+}{\left(\frac{Ca^{++} + Mg^{++}}{2}\right)^{\frac{1}{2}}}$$

where the cations are expressed as meq/l.

Generally the sodium hazard of soil increases with the increase of PSS or SAR of irrigation water and exchangeable sodium percentage of the soil. The maximum permissible value of PSS in irrigation water is 60. Where waters with higher PSS values are used, gypsum should be added to the soil occasionally for soil amendment. SAR values greater than 18 may adversely affect the permeability of soils.

7.3.1.5 Residual Sodium Carbonate

Hazardous effect of sodium is also increased, if the water contains bicarbonate and carbonate ions in excess of the calcium and magnesium. In such cases there is a tendency for calcium and magnesium to precipitate as carbonates from the soil solution and thereby increase in the relative proportion of exchangeable sodium. Values of residual sodium carbonate (RSC) less than 1.25 mg/l are considered safe and above 2.5 mg/l as unsuitable.

$$\text{RSC} = (\text{CO}_3^{2-} + \text{HCO}_3^-) - (\text{Ca}^{2+} + \text{Mg}^{2+}) \quad (7.2)$$

where all ionic concentrations are expressed as mg/l. However, it has been witnessed in some arid locations that after the micro irrigation and spray irrigation on land, the bicarbonate salt of Calcium precipitates as its carbonates due to incremental water loss and heating from sun rays. In sensitive locations as lawns in recreational areas, it may be better to convert the bicarbonate to chlorides by acidification if needed. The effect of potassium on soil is similar to that of sodium, but since the concentration of potassium is generally quite small in irrigation waters, it is often omitted from consideration.

7.3.1.6 Organic Solids

While stable organic matter improves porosity of soil, thereby facilitating aeration, an excessive application of unstable organic matter would lead to oxygen depletion in the soil. Depositing of sediments especially when they consist primarily of clays or colloidal material may cause crust formations, which impede emergence of seedlings. In addition, these crusts reduce infiltration with the consequent reduction of irrigation efficiency and less leaching of saline soils.

7.3.1.7 Other Considerations

Soils are usually well buffered systems. The pH is not significantly affected by application of irrigation water. However, extreme values below 5.5 and above 9.0 will cause soil deterioration. Development of low pH values in soils promotes dissolution of elements such as iron, aluminium or manganese in concentrations large enough to be toxic to plant growth. Similarly, water having high pH values may contain high concentration of sodium, carbonates and bicarbonates, the effect of which has been discussed earlier.

Chlorides and sulphates are toxic to most crops in high concentrations. Ordinarily, the detrimental effects of salinity on crop growth become perceptible first. Excessively high or low temperature in irrigation water may affect crop growth and yields. A desirable range of water temperature is from 12 to 30°C.

7.3.1.8 Design and Management of Sewage Farms

Optimum utilization of sewage in agriculture means the complete and judicious use of its three main components, viz., water, plant nutrients and organic matter on the farms in such a way that (a) the pathogenic infection is neither spread among the farm workers, nor among the consumer of sewage farm products, (b) the groundwater is not contaminated, (c) there is maximum output per unit volume of sewage, (d) there is no deterioration of the soil properties and (e) none of the three components are wasted.

7.3.1.9 Management of Water in Sewage Farming

The principle to be borne in mind in irrigation management is to irrigate only when it is required and only to the extent it is required by the crop. The water requirement depends on the soil type, the crop and the climate. The water requirement (cm) of main soil types to be wetted to a depth of 30 cm required by most of the crops is given in Table 7.12.

Table 7.12 Water requirements (cm) to wet different soils to a depth of 30 cm

No.	Soil	Requirement	No.	Soil	Requirement
1	Sandy	1.25	4	Clay Loam	6.25
2	Sandy Loam	2.50	5	Clayey	7.50
3	Loam	5.00			

Source: CPHEEO, 1993

Water requirement of crops vary with the duration of their growing season and the amount of growth in unit time. Details for some of the Indian crops that can be grown on sewage farms are given in Table 7.13.

Table 7-13 Water requirements of crops

No.	Crops	Growing period,(days)	Total water requirement ,cm)	Optimum pH range
1	Soybean	110-120	37.50	6.0-8.5
2	Mustard	120-140	37.50-55.00	6.0-9.5
3	Sunflower (kharif)	100-110	37.50	6.0-8.5
4	Sunflower (rabi)	110-120	87.50	6.0-8.5
5	Barley	88	35.25	6.5-8.5
6	Cotton	202	105.50	5.0-6.05
7	Jowar	124	64.25	5.5-7.5
8	Maize	100	44.50	5.5-7.5
9	Linseed	88	31.75	5.0-6.5
10	Rice	98	104.25	5.0-6.0
11	Milling Varieties of sugarcane	365	237.50	6.0-8.0
12	Wheat	88	37.00	5.5-7.5

Source: CPHEEO, 1993

7.3.1.9.1 Hydraulic Loading

The elements to be considered in determining hydraulic loading are the quantity of effluent to be applied, precipitation, evapotranspiration, percolation and runoff. For irrigation systems, the amount of effluent applied plus precipitation should equal the evapotranspiration plus the amount of percolation. In most cases, surface runoff from fields irrigated with sewage effluent is not allowed or must be controlled.

The water balance.

$$\text{Precipitation} + \text{Sewage application} = \text{Evapotranspiration} + \text{Percolation}$$

Seasonal variations in each of these values should be taken into account by evaluating the water balance for each month as well as the annual balance. The irrigation requirement of any crop is not uniform throughout its growing period. It varies with the stage of growth. For example grain crops require maximum irrigation during the time of ear-head and grain formation. Sugarcane requires more frequent irrigation from about the sixth or the seventh month onwards. In case of fruit trees the irrigation has to be stopped during their resting period. If the irrigation is not given at critical growth stages of the crop, it results in lower yields.

The water requirement of crop at different stages of growth can be determined either directly (gravimetrically) or indirectly by use of tensiometers or irrometers or gypsum blocks. Normally, when there is about 50% depletion of available moisture in the soil, irrigation is recommended. The crop plants themselves show signs of moisture stress. One has to be always on the lookout for such first symptoms to determine the need for irrigation. Some plants like sunflower also serve as good indicators of stress symptoms. Sunken screen pan evaporimeter could also be used for estimating use of water by crop plant and scheduling irrigation.

The extent of irrigation depends on the depth of irrigation to be given and volume of water required for wetting the soil to the required depth. If tensiometers or gypsum blocks are embedded at the required depths, they would indicate the stage when the soil at that depth is saturated. Nearly about 70% to 80% roots of most crops are found in the first 30 cm of the soil. Some may go deeper to the next 30 cm. Normally, in irrigating medium type of soil it is wetted to about 30 cm depth or a little more. If the figures for water requirements for crops as mentioned in Table 7.13 are to be satisfied, much higher hydraulic loadings have to be applied since a portion of sewage after its passage through the soil is carried away by the sub-soil under drainage system. The extent of desirable percolation rate depends upon the salinity of the irrigation water. The applicable hydraulic loadings of settled sewage are therefore dependent upon the type of soil and the recommended rates are given in Table 7.14.

Table 7.14 Recommended hydraulic loadings

No.	Soil	Hydraulic Loading (cum/ha/day)	No.	Soil	Hydraulic Loading (cum/ha/day)
1	Sandy	200 - 250	4	Clay Loam	50 - 100
2	Sandy Loam	150 - 200	5	Clayey	30 - 50
3	Loam	100 - 150			

Source: CPHEEO, 1993

Sewage conforming to the norms should be applied to the soil by strip, basin or furrow irrigation, Wild flooding should not be adopted. Sprinkler irrigation could be used for adequately treated sewage. The distribution channels should be properly graded to avoid ponding and silting. It is advisable that the main distributary channel is lined.

7.3.1.9.2 Organic Loading

Values of 11.0 to 28.0 kg/ha/day of organic loading in terms of BOD₅ is needed to maintain a static organic matter content in the soil that helps to condition the soil by microorganisms without solid clogging. Higher loading rates can be managed depending on the type of system and the resting period. When primary effluent is used, organic loading rates may exceed 22.0 kg/ha/day without causing problems.

7.3.1.9.3 Irrigation Interval

Resting periods for surface irrigation can be as long as 6 weeks, but is usually between one and two weeks during which, the soil bacteria break down organic matter and the water is allowed to drain from the top few centimetres, thus restoring aerobic condition in the soil. It depends upon the crops, the number of individual plots in the rotation cycle and management consideration.

7.3.1.10 Management of Soil

A well-planned programme of crop growth and harvesting can help to maintain a soil receptive to effluent application. Crop uptake of nutrients followed by removal of the crop from the field increases the capacity of the land for removal of nutrients from the next effluent application. It is necessary that the soil is given rest for about 3 to 4 months every alternate or third year preferably in summer months. This can be achieved if the farm is designed on the basis of water requirement in the winter season. After the harvest of the crop, the soil may be opened up by deep ploughing and cultivated appropriately to make it as porous and permeable as possible before the next crop is raised.

The maintenance of soil oxygen level is very important as it is required for root respiration and a number of biological processes in the soil. Refilling of oxygen in the pores in the surface layers of soil depends upon the reestablishment of contact of the soil with the atmosphere. This process can be accelerated by suitable cultural practices and by providing sufficient irrigation intervals. It is therefore, desirable that an intercultural operation is followed as soon as the soil condition allows working after every irrigation. It should always be seen that the soils of sewage farm should have a surplus of oxygen than that normally required in the ordinary farm because the soil oxygen has to perform an additional job of satisfying the BOD of sewage.

The intercultural operation following one or two irrigations is all the more necessary in the case of clayey soil. In areas where rainfall is low, it is desirable to flood the soils with irrigation water at least once a year to leach down the salts accumulated in the soil. If the soil salinity and alkalinity pose a serious problem, amendment of soil with the required quantity of gypsum should be carried out. Subsoil drainage is very important. Poor drainage should be improved by installing underground drains. Sewage farm fields must be laid out in accordance with the natural slope of the terrain to eliminate the irregularities of distribution.

On sewage farms, no sewage should be allowed to flow beyond the farm boundaries. With this in view, protection banks are arranged along the lowest lying boundaries of each crop rotation field.

7.3.1.11 Nutrients Loading

Sewage contains 26-70 mg/l of nitrogen (N), 9-30 mg/l of Phosphate (P₂O₅) and 12-40 mg/l or even more of potash (K₂O). The recommended dosages for N, P and K for majority of field crops are in the ratio of 5:3:2 or 3 respectively. The figures for N, P, and K contents of sewage on the other hand show that sewage is relatively poor in phosphates. Excess potash is not of significance, but a relative excess of nitrogen affects crop growth and development.

Crops receiving excessive dosage of nitrogen show superfluous vegetative growth and decrease in grain or fruit yield. The phosphate deficit of sewage, therefore, should be made good by supplementing with phosphate fertilizers, the extent of phosphate fortification depending upon the nature of crop and its phosphate requirements. As the availability of phosphate is low in the irrigation water it would be desirable to apply the required quantity of phosphatic fertilizer at the time or even (about a fortnight) before the sowing or planting of the crop.

Even when sewage nutrients are balanced by fortification, irrigation with such sewage may supply excessive amount of nutrients resulting in waste or unbalanced growth of plants with adverse effects on yields. It may therefore be necessary to dilute the sewage. Dilution also helps in reducing the concentration of dissolved salts and decomposable organic matter in the sewage thus, decreasing hazards to the fertility of the soil. It is desirable to limit the BOD and total suspended solids of sewage to be disposed on land for irrigation, as per relevant standards. There is a need to take caution on describing nutrient supply capacity of sewage particularly in the case of availability of phosphorus because there is a possible conversion of available phosphorus in unavailable mode in the presence of heavy metals present in the sewerage. This happens commonly in high as well as low pH soils.

7.3.1.12 Land Requirements for Hydraulic and Nitrogen Loadings

The field-area requirement for farming based on the hydraulic loading rate is calculated by:

$$A = [3.65 Q/L] \quad (7.3)$$

where

- A = Field-area in hectares
- Q = Flow rate in cum/day
- L = Annual liquid loading, cm/year

For loading of constituents such as Nitrogen

$$A = [0.365 CQ/L_c] \quad (7.4)$$

where

- C = Concentration of the constituents, mg/l.
- L_c = Loading rate of the constituent, kg/ha/year.

7.3.1.13 Alternative Arrangement during Non-irrigating Periods

During rainy and non-irrigating seasons, sewage farm may not need any water for irrigation. Even during irrigating season, the water requirement fluctuates significantly. Hence, satisfactory alternative arrangements have to be made for the disposal of sewage on such occasions either by storing the excess sewage or discharging it elsewhere without creating environmental hazards. The following alternatives are generally considered:

- a) Provision of holding lagoons for off-season storage. They enable irrigation of a fixed area of land to varying rates of crop demand. They may also serve as treatment units such as aerated or stabilization lagoons, provided the minimum volume required for treatment is provided beyond the flow-balancing requirement.
- b) Provision of additional land where treated sewage is not required on the main plot of land
- c) Discharge of surplus treated sewage to river or into sea with or without additional treatment. Combining surface discharge facilities with irrigation system is quite common and often quite compatible.
- d) Resorting to artificial recharge in combination with an irrigation system where feasible.

7.3.1.14 Protection against Health Hazards

Sewage farms should not normally be located within 1 km of sources of centralized water supply, mineral springs in the vicinity, where water bearing layers prevail; or on areas with groundwater levels less than 2 m below the surface. Measures should be taken to prevent pollution of artesian water. Sewage farms must be separated from residential areas by at least 300 m horizontal distance. The public health aspects of sewage farming should be considered from the viewpoints of exposure of farm workers to sewage and that of the consumers to the farm products.

Evidence is on the increase to show that labourers working on the sewage farms suffer from a number of ailments directly attributed to handling of sewage. In view of this it is desirable to disinfect sewage and where feasible mechanize sewage farm operation.

Sewage of individual enterprises engaged in the processing of raw material of animal origin or hospitals, bio-factories and slaughter houses should in addition be disinfected before they are taken to the sewage farms. Agricultural utilization of sewage containing radioactive substances is to be guided by special instructions.

The staff of sewage farms must be well educated in the sanitary rules on the utilization of sewage for irrigation as well as with personal hygiene. All persons working in sewage farms must undergo preventive vaccination against enteric infections and annual medical examination for helminthoses and be provided treatment if necessary.

Sewage farms should be provided with adequate space for canteens with proper sanitation, wash-stands and lockers for irrigation implements and protective clothing. Safe drinking water must be provided for the farm workers and for population residing within the effective range of the sewage farms.

All farm workers should be provided with gum boots and rubber gloves, which must compulsorily be worn while at work. They should be forced to observe personal hygiene such as washing after work as well as washing before taking food. The use of antiseptics in the water used for washing should be emphasized. The farm worker should be examined medically at regular intervals and necessary curative measures enforced.

Cultivation of crops that are eaten raw should be banned. Cultivation of paddy in bunded fields is likely to give rise to sanitation problems and hence is undesirable. Growing of non-edible commercial crops like cotton, jute, fodder, milling varieties of sugarcane and tobacco would be suitable. Cultivation of grasses and fodder legumes, medicinal and essential oil yielding plants like menthal and citronella may be allowed. Cultivation of cereals, pulses, potatoes and other crops that are cooked before consumption may be permitted, if sewage is treated and care is taken in handling the harvests to ensure that they are not contaminated. Cultivation of crop exclusively under seed multiplication programmes would be advantageous as these are not consumed. As an additional safeguard, sewage irrigation should be discontinued at least two months in advance of harvesting of fruits and berries, one month for all kinds of vegetables and a fortnight for all other crops. Direct grazing on sewage farms should be prohibited.

7.3.2 Guiding Principles — Farm Forestry

Much of the provisions in Section 7.3.1 shall apply here also except that the SAR and RSC criteria may not be of serious importance. Besides, the non-water needs in rainy periods are to be borne in mind for diverting the treated sewage away from the farm forestry. It will be a better proposition to carry out all treatments at the STP itself and not split between STP and farm.

7.3.3 Guiding Principles - Horticulture

Same as in Section 7.3.2 above, except that the TDS limit shall not exceed the TDS limit of the groundwater at any time and even if the RSC limitation is met, the alkalinity to be moved from bicarbonates to chlorides or sulphates to prevent scaling of the tender leaves and petals in high summer and also choking the soil pores by evaporation of the temporary hardness.

7.3.4 Guiding Principles - Toilet Flushing

Considering that the Indian water closets when flushed can sprout and splash the flush water above the rim and onto the foot rest areas, it is necessary that such reuse shall be only after activated carbon and ultra filtration membranes. It shall not be made mandatory in layouts and confined condominiums and multiplexes and encouragement and persuasion shall be adopted, than a collision course or mandating it which is not justifiable by any means for if nothing else, sentimental reasons which rule high in Indian way of life. Similarly, small layouts being mandated to provide STP is to be viewed as decentralized sewerage and the sustainability of these by the proposed number of plot owners shall be assessed before sanctioning them, as otherwise, the policy of septic tanks on-site followed by twin drain shall be encouraged as a practical possibility. In any case, small layouts shall not be forced to erect reuse practices as absence of proper O&M can only create a mini epidemic of sorts.

7.3.5 Guiding Principles - Industrial and Commercial

The reclaimed water from the sewage renovation plant of M/S MFL is reported to have been demonstrated for its quality by the engineer drinking it himself before the team of the World Bank during 1995. However, it shall not be accepted as an endorsement of drinkability. All the same, It should be accepted as a statement of the capability, in the country to build a plant of such advanced technology and encourage similar widespread uses in other industrial sectors for non-human contact reuse. Industrial reuse of treated sewage includes the following:

- Once through cooling water
- Recirculating evaporative cooling water
- Boiler feed water
- Non-human contact process water
- Irrigation of landscape around industrial plants

Once through Cooling Water:

In addition to recommended surface water discharge standards, > 1 mg/l residual chlorine can serve the purpose (US EPA 2004).

Re-circulating or Evaporative Cooling Water:

In addition to the once through cooling standards, additional criteria are salt build-up that is discussed in the following section. Additional treatment is usually provided to prevent scaling, corrosion, biological growths, fouling and foaming (US EPA 2004).

Boiler Feed Water:

It requires extensive treatment to reduce hardness and even demineralization. Hence, RO or ion exchange process with suitable pre-treatment are required to achieve boiler feed water quality for high pressure boilers.

Process Water:

It depends on the quality of process water required by specific industry on a case-by-case basis.

Irrigation and Maintenance of Landscape around Industrial Plants:

Please refer the guiding principles discussed in above sections.

7.3.5.1 As Cooling Water

Reuse as cooling water is one of the most common industrial applications of reclaimed treated sewage. Typical guidelines for cooling water quality are given in Table 7.15 (overleaf) and may be used where specific requirements are not given.

Table 7.15 Cooling water quality guidelines

No.	Parameter/Condition	Recommended value
(A)-In make-up water		
1	pH	6.8-7.0 (variation less than 0.6 units in 8 hours)
2	Average TDS value (with variation + 25% permissible on 8 hour average)	Cycles of concentration in re-circulating water
	3,000 mg/l	2.0
	1,000 mg/l	3.5
	500 mg/l	6.0
3	Oil & grease	Absent
4	BOD (5day, 20°C)	Less than 5.0 mg/l
5	Chlorides (Cl)	Less than 175 mg/l
6	Ammonia	No appreciable amount
7	Caustic alkalinity	Absent
8	Methyl orange alkalinity (as CaCO ₃)	Less than 200 mg/l
(B)-In re-circulating water		
9	Silica (As SiO ₂)	Less than 150 mg/l
10	Phosphates, sulphates	Not to exceed solubility limit in re-circulating water
11	Alkyl Benzene Sulphonate (ABS)	Foam not to persist more than 1 minute after 10 seconds of vigorous shaking of re-circulating water
12	Langelier index at skin temperature of heat exchange surface	0.5±0.1
13	Ryzner Stability Index	6.0 to 7.0

Source:CPHEEO, 1993

To determine the quality and quantity of water required for reuse in a cooling system, where an open re-circulating system is adopted for air conditioning cooling water, the amount of water to be kept for re-circulating in the system is approximately 11 litres/min for every ton of refrigeration capacity when the temperature drop is 5°C in the cooling tower. For such a situation, the water lost in evaporation (E) is about 1% of the re-circulating water.

Windage loss (W) is of the order of 0.1 to 0.3% of the recirculating water when mechanical draft towers are used, but increases to 0.3 to 1.0% for atmospheric towers. Blow down requirement (B) is estimated from the following equation if the maximum permissible cycles of concentration (C) are known

$$B = \frac{E + W(1 - C)}{C - 1} \quad (7.5)$$

where, B, E and W are all in lpm.

For trouble free operation and minimum use of water quality control chemicals in the recirculating water, the cycles of concentration are generally kept at 2.0 to 3.0 and, in no case, more than 4.0 in cooling towers where reclaimed water is used.

The quality guidelines for cooling water are included in Table 7.15. Hence, for a 100-ton air-conditioning plant recirculating 1100 litres/min of water with a temperature drop of, say 10°C through a mechanical draft tower where cycles of concentration are to be restricted to 2.0

$$E = 2\% \times 1100 = 22 \text{ litres/min}$$

$$W = 0.2\% \times 1100 = 2.2 \text{ litres/min}$$

$$B = \frac{22 + 2.2 \times (1 - 2)}{2 - 1} = 20 \text{ liters/min (approximately)}$$

The total make-up water requirement thus equals 44.2 litres/min (= 22 + 2.2 + 20) or 63.4 m³/day for 24 h working of a 100-ton plant.

Similarly, if 3.0 cycles of concentration are permissible, the total requirement of make-up water reduces to 47.7 m³/day for a 100 ton plant.

When cycles of concentration equal 3.0, the various stable constituents (e.g. chlorides) in make-up water are theoretically increased by a factor of 3.0 in the re-circulating water. If the concentration of various constituents in the make-up water lies within the range of values given in column (A) to (F) of Table 7.16 the corresponding concentration in the recirculating water can be readily estimated. For example, if Cl is 60 mg/l in the make-up water, they will increase to 180 mg/l in the re-circulating water. However, the pH of the re-circulating water cannot be estimated in this manner.

The assumption is frequently made that in the absence of phenolphthalein alkalinity, the pH of the water leaving the cooling tower will be between 8.0 and 8.3, due to elimination of free carbon dioxide in the tower. Sometimes, for other reasons, a lower or higher pH may be observed. Thus knowing the pH, the concentrations of calcium, alkalinity and total dissolved solids in the re-circulating water and the temperature in the hottest part of the system, one can determine the Langelier index and Ryzner stability index and the tendency of the water to scale or corrode. Assuming that the recirculating water shows the tendency for deposition of scale, reduction in hardness and in alkalinity is the usual means of control. Since nothing can be done to reduce temperature, reduction in total solids would not have much effect on the Index

For this reason, partial zeolite softening (by blending the softened water with by-passed hard water), plus acid feeding if required for reduction of alkalinity provide a relatively simple and flexible means of preventing excessive scaling in this type of installation.

The blending ensures a certain amount of hardness in the water, which is useful to protect against corrosion of ferrous heat exchanger surfaces. The acid treatment (using H₂SO₄) depends for its functioning on the fact that calcium and magnesium sulphates are much more soluble than the carbonates, with the usually adopted dosages and the cycles of concentration obtaining in the system, calcium sulphate concentrations obtaining in the system.

Calcium sulphate concentrations are well below the solubility limit. Similarly, calcium phosphate is also kept within the solubility limit.

Automatic dosing and control equipment is normally not provided in plants in India. The clear water storage tanks helps to maintain uniformity of quality of water pumped to the cooling towers. Storage ensures that pH, total dissolved solids, etc., do not vary much from hour to hour and the wide variations in inflow quantities are balanced out.

Pre-chlorination is done as the water enters the coagulation tanks, while post-chlorination is mainly in the form of periodic “shock” doses to control lime and algal growths. The latter are likely to form owing to the presence of nitrates and phosphates in the treated water and the warm and sunny climate of India.

A typical flow sheet for making sewage water fit for reuse as once through cooling water is given in Figure 7.22.

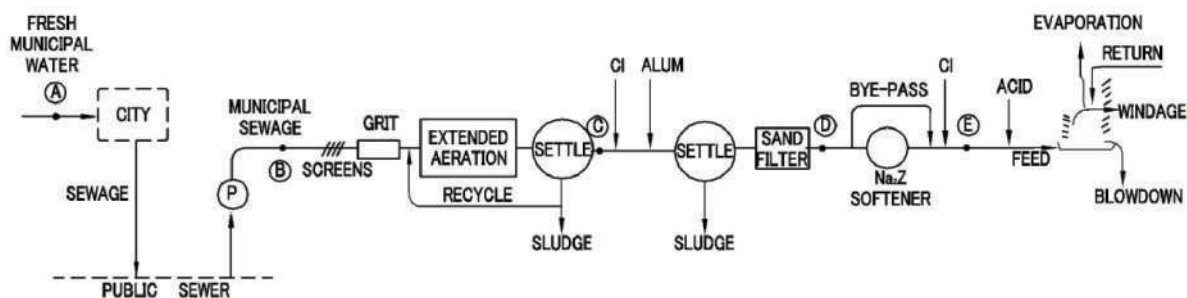

Source:CPHEEO, 1993

Figure 7.22 Flow sheet for treatment of municipal sewage for reuse as cooling tower make-up water

For reuse as make up water in cooling systems, the treatment processes given earlier in Figures 7-1 to 7-6 are to be evaluated and suitable scheme evolved. The removal of ammonia by air stripping is not to be used as this leads to air pollution issues. Instead biological nitrification-denitrification could be used.

Table 7.16 (overleaf) gives an illustrative example of the change in water quality as fresh municipal water becomes sewage and is gradually renovated for reuse as cooling and process water.

Where nitrates and phosphates in the make-up water are necessary to be reduced, the biological treatment given to sewage at the secondary stage can itself be modified to include nitrification-denitrification and the addition of alum or ferric done in the final settling tank or add on tertiary high lime treatment with recarbonation is opted to precipitate phosphates.

If high lime is used, it will also knock out silica in proportion to mg and can be enhanced in removal by adding dolomite to increase the Mg content.

7.3.5.2 As Boiler Feed Water

Reuse as boiler feed water may require additional treatment over that required for cooling purposes. As boiler feed, the quality of water depends on the boiler pressures at which steam is to be raised. The higher the boiler pressure, the purer the water required.

Table 7.16 Water quality changes as freshwater becomes sewage and is gradually treated for reuse (illustrative example)

Item	Water quality at different treatment steps					
	Fresh municipal water	Raw domestic sewage	After biological treatment	After coagulation and filtration	After softening & chlorination	After DS and DM
	(A)	(B)	(C)	(D)	(E)	(F)
pH	7.6-7.8	7.15-7.65	7.2-7.8	7.1-7.3	7.1-7.2	≈7.00
Total Hardness mg/l as CaCO ₃	35-40	120-160	120-160	120-170	40 (a)	As arising
M.O. Alkalinity mg/l as CaCO ₃	40-45	125-200	125-200	110-180 (b)	110-180	As arising
Chlorides mg/l, as Cl	15-20	60-130	60-120	60-130	60-130	As arising
Sulphates mg/l as SO ₄	1.5-2.5	10-20	10-15	15-25	15 -25	As arising
Phosphates mg/l as PO ₄	Traces - 0.1	6-16	3-10	0.2-0.5	0.2-0.5	Nil
Nitrates mg/l as NO ₃	1.0-2.0	1.0-3.0	13-19	13-19	13-19	As arising
Silica mg/l as SiO ₂	8-24	10-24	10-24	10-20	10-20	As arising
Dissolved solids mg/l	80-500	850–1,350.	850–1,350	800-1,350	600-1150	< 500
Suspended solids mg/l	5-10	350-450	15-30	Nil.	Nil.	Nil
Turbidity SiO ₂ , Units	5-10	Turbid	10-20	2.0-3.0	2.0-3.0	2.0–3.0
BOD, mg/l	0.1-1.5	200-250	6-10	1.0- 2.0	1.0-1.5	Nil
COD, mg/l	1.0-2.0	350-500	150-270	150-270	100-180	< 70
Bacteriological quality (as per coliform standards)	Safe	Unsafe	Unsafe	Safe	Safe	Safe
Specific conductance						700

a) Softened water is blended with un-softened water to give a final hardness of 40 mg/l as in fresh municipal water.

b) Alkalinity is reduced by acid treatment just prior to use in cooling towers. This increases sulphate content somewhat since H₂SO₄ is used.

Source: CPHEEO, 1993

Table 7.17 gives an indication of the water quality required for low and medium pressure boilers.

Characteristic	Requirement for Boiler pressure			Method of test (Ref to clause)	
	Up to 2.0 Nm/m ²	2.1 to 3.9 Nm/m ²	4.0 to 5.9 Nm/m ²	IS: 3550 (a)	IS: 3025 (b)
Feed water					
a) Total hardness (as CaCO ₃) mg/l, max	1.0	1.0	0.5		16.1
b) pH Value	8.5 to 9.5	8.5 to 9.5	8.5 to 9.5		8
c) Dissolved oxygen mg/l, max	0.1	0.02	0.01	25	
d) Silica (as SiO ₂) mg/l, max		5	0.5	16	
Boiler water					
a) Total hardness (of filtered sample) (as CaCO ₃) mg/l, max	Not Detectable				16.1
b) Total alkalinity (as CaCO ₃) mg/l, max.	700	500	300		13
c) Caustic alkalinity (as CaCO ₃)mg/l, max	350	200	60		15
d) pH value	11.0 to 12.0	10.0 to 12.0	10.5 to 11.0		8
e) Residual sodium sulphite (as Na ₂ SO ₃) mg/l	30 to 50	20 to 30			21
f) Residual Hydrazine (as N ₂ H ₄) mg/l	0.1 to 1 (if added)	0.1 to 0.5 (if added)	0.5 to 0.3	26	
g) Ratio Na ₂ SO ₄ caustic alkalinity (as NaOH)		Above	2.5		20.2 and 15
Or					
Ratio NaNO ₃ total alkalinity (as NaOH)		Above	0.4		48 and 13

a) Methods of test for routine control for water used in Industry

b) Methods of sampling and test (Physical and Chemical) for water used in Industry.

Source: CPHEEO, 1993

For low pressure boilers, the quality of water required is more or less similar to that for reuse in cooling purposes. For high pressure systems, the treatment required can be quite substantial as can be seen from the water requirements given in Table 7.18 (overleaf).

Table 7.18 Requirements for feed water, boiler water and condensate for water - tube boilers (drum type)

Characteristic	Requirements for boiler pressure mm/m ² (in the drum)				Method of test to Clause No. of		See also Clause
	6.0-7.8	7.9-9.8	9.9-11.8	Above 11.8	IS: 3550 (a)	IS: 3025 (b)	
pH	6.0-7.8	7.9-9.8	9.9-11.8	Above 11.8	IS: 3550 (a)	IS: 3025 (b)	
Total hardness(1)	Nil	Nil	Nil	Nil		16.1	
pH value	8.5-9.5	8.5-9.5	8.5-9.5	8.5-9.5		8	2.1.1(a)
Oxygen, O ₂ mg/l, max	0.01	0.005	0.005	0.005	25		2.1.1(b)
Iron + copper mg/l, max	0.02	0.01	0.01	0.01	(2)		2.1.1(c)
Silica (SiO ₂) max	0.05	0.02	0.02	0.02	(3)		2.1.1 (d)
Oil mg/l, max	Nil	Nil	Nil	Nil		59	
Residual hydrazine(2)	0.05	0.05	0.05	0.05	26		
Conductivity (3)	0.5	0.3	0.3	0.3	7		
Oxygen consumed (4)	Nil	Nil	Nil	Nil		51	

a) Methods of Test for routine control for water used in Industry

b) Methods of sampling and test (Physical and Chemical) for water used in Industry.

(1) as (CaCO₃) mg/l, max, (2) as (N₂H₄) mg/l, max, (3) after passing through cation exchange column at 25 deg C microsimens/cm, max, (4) in 4 hours mg/l, max

Source: CPHEEO, 1993

A typical flow sheet given in Figure 7.23 includes tertiary treatment in the form of chlorination, chemically aided sedimentation, sand filtration, sodium zeolite softening followed by cation exchange on hydrogen cycle, degasification and weak base anion exchange to give practically complete demineralization. Where the TDS is higher, technologies such as RO, evaporation, etc., should also be considered.

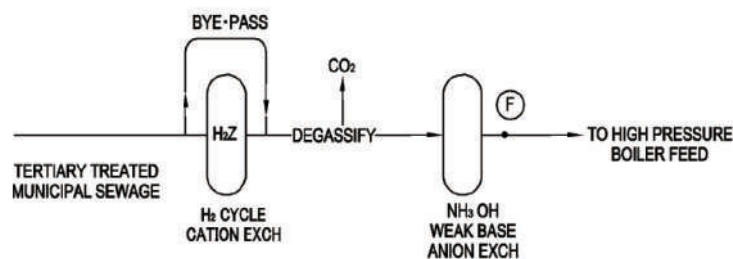

Figure 7.23 Flow sheet for reuse of treated sewage as high pressure boiler feed when TDS in sewage is very low in the region of about 300 mg/l or so

7.3.5.3 As Process Water

In order to keep treatment to a minimum for reuse as process water, one benefits from identifying those processes that must have freshwaters of high quality and those processes that can do with reclaimed water of low quality (e.g. similar in quality to that used for cooling or for low pressure boilers). This is done by having a multiple quality water supply system within the industry. Indian standards for quality tolerances for a few industrial uses are noted below:

- IS: 201 Water quality tolerances for the textile industry
- IS: 2724 Water quality tolerances for the pulp and paper industry

- IS: 3957 Water quality tolerances for ice manufacture
- IS: 4251 Water quality tolerances for the processed food industry
- IS: 4700 Water quality tolerances for the fermentation industry

It may be noted that generally all the processes in an industry do not require water of the relatively high quality given in the above noted Indian Standards. There are always several unit processes and operations where water of lesser quality can be tolerated. The issue of relevance in respect of industrial use is the crucial factor of reducing the TDS to about 500 mg/l as compared to the typical sewage value of 1,200 mg/l and above. This at some stage implies recourse to RO and the difficulty of dealing with rejects. It will be better to allow the user to discharge it back in the sewer itself at an appropriate location and charge an additional fee for the same, so that the practice will find a wider acceptance and take off towards a real success. Further the example of increasing the treatment capacity in the pre RO section to such a quantity that the bypassed stream before RO and the RO rejects stream when blended will be able to hold the TDS to less than 2,100 mg/l, the permissible value needs to be followed.

7.3.6 Guiding Principles - Fish Culture

Recognizing that Kolkata city is unique in having fish as an acceptable food and thus, the demand being steady. Fish ponds otherwise referred to as pisciculture cannot be looked upon as a method of stand-alone sewage treatment. However, treated / diluted sewage if used for pisciculture on the lines of the on-going East Kolkata wetlands, this needs to be strictly monitored by Department of Health and Department of Environment / SPCB and also the social acceptability.

7.3.7 Guiding Principles - Groundwater Recharge

At this point of time, the spread in the infiltration basins is fraught with many challenges as dust control, algae problems and essentially silica ingress into groundwater, in addition to the danger of the TDS and nitrate of applied sewage being higher than the TDS and nitrate of the groundwater. Further, financial ability of local bodies may not support this expenditure, which does not generate revenue except on a notional scale. On the contrary, if it is deep well injection on the lines of the first version of the Orange County plant, where injection wells were driven to about 100 m below ground to prevent seawater intrusion in water short coastal area, can be encouraged with appropriate safeguards.

7.3.8 Guiding Principles - Indirect Recharge of Impoundments

It is too early to embark on this till the results of the Bengaluru piloting are validated.

7.3.9 Guiding Principles – Indirect Reuse as Potable Raw Water Source

The indirect use of treated sewage has been going on in many ways and is detailed below. The reason that indirect water reuse is not to be considered to pose a health risk is that the treated wastewater benefits from natural treatment from storage in surface water and aquifers and is diluted with 'ordinary' river/ground water before abstraction to ensure good drinking water quality (part of a multi barrier approach in the water safety plan).

The storage time provides a valuable buffer to measure and control quality (Source: <http://www.ciwem.org/policy-and-international/current-topics/water-management/water-reuse/potable-water-reuse.aspx>).

7.3.9.1 Treated Sewage into Perennial Rivers

When sewage is treated and discharged into perennial flowing rivers and the blended river water is drawn downstream of the point of such blending as raw water for treatment in public water supply schemes. This is indirect potable use after blending. This is historical and ongoing all around. However, of late, the organic load due to the discharged treated, partially treated and non point sewage becomes in excess of the self purifying capacity of the river. Thus, the river water is not actually freshwater. The water quality of Yamuna river for Agra water supply scheme requires to be first treated in MBBR to purify the river water to a level as raw water for the downstream WTP. When it passes through flowing surface water it has the potential disadvantages of contamination by human and animal activities adding organic matter and waterborne pathogens unless the river stretch is protected from such activities. The guiding principle in such cases for the ULBs will be to at least intercept the sewage outfalls and provide adequate STPs and follow the recommended quality criteria for the treated sewage as in Table 5.20 of Chapter 5 in Part A manual.

7.3.9.2 Treated Sewage into Non-Perennial / Dry River Courses

There are locations where the rivers are not perennial or almost dry throughout the year except some monsoon runoff. In this case the discharged treated sewage sinks into the aquifer zone and is extracted by infiltration wells or galleries. The advantage of direct dilution from surface water is lost, but the additional purification in the soil and dilution from the aquifer water are happening. An example is the case of the Palar river course in Tamilnadu. The surface water flow in this occurs only for about a week if the monsoon is normal and if the water spills beyond the upstream impoundments. The aquifer however supports the public water supply of over 30 habitations along its dry tract of nearly 80 km before the sea. The partly treated sewage of the en route habitations do reach this river course as intervals. So far, no epidemics have been met with. This may be due to the above said additional purification in the soil and dilution by aquifer water. However, if these are exceeded by the contamination load, there can be immediate health problems. The guiding principle in such cases for the ULBs will be (a) to keep a check on the raw water quality from the infiltration wells to detect sudden increase in contaminants and (b) at least intercept the sewage outfalls and provide adequate STPs.

7.3.9.3 Treated Sewage into Surface Water Reservoirs

This may occur when the surface water reservoirs receive the inflow from rivers and become impoundments from which the raw water is taken for public water supplies. Here also, the same position as in 7.3.9.1. would apply.

When it passes through reservoirs, it has the potential issues of evaporation losses and algae. The algae creates taste and odour concerns and metabolic products of dead and decaying organisms as precursors which on chlorination are suspected to cause Trihalomethanes.

Upon chlorination, the residuals of insecticides and fertilizers are referred to as Endocrine Disruptor chemicals (EDCs) and this requires the use of Granular Activated Carbon filtration and sanitary protection of the catchments.

The case of Hosur in Tamilnadu is an example. The Kelavarampalli river was impounded here to take the raw water to the conventional WTP for the town. During 2004, the partial drought resulted in reduced flow in the river and the impoundment water slowly concentrate with dead and living algae.

The conventional WTP could not treat the foul smelling coloured water and the high Lime and carbonation technology had to be retrofitted into the WTP on an urgent scale as otherwise, the town had to be evacuated. The cost of treatment jumped from Rs 4 to 14 per Kilo litre, but there was no other option. The guiding principle in such cases for the ULBs will be to ensure sanitary protection of the catchment, monitor the quality of the water entering the reservoir and keep contingency plans to switch the WTP into an appropriate mode to meet the raw water quality and also keep a contingency budget allocation for the increased O&M costs in such periods.

7.3.9.4 Treated Sewage into Conjunctive Uses in Surface Water and Aquifer

Conjunctive use of surface water and aquifer water is also being practiced as a method of indirect potable reuse.

Berliner Wasserbetriebe is reported to treat the 248 MLD of treated sewage to recharge surface water lakes, and the surface water is in turn used to recharge aquifers through artificial infiltration ponds and bank filtration by means of natural lakes.

The groundwater is stated to be then abstracted to supply 3.4 million people in Berlin with drinking water without chlorination. A schematic depiction is shown in Figure 7.24.

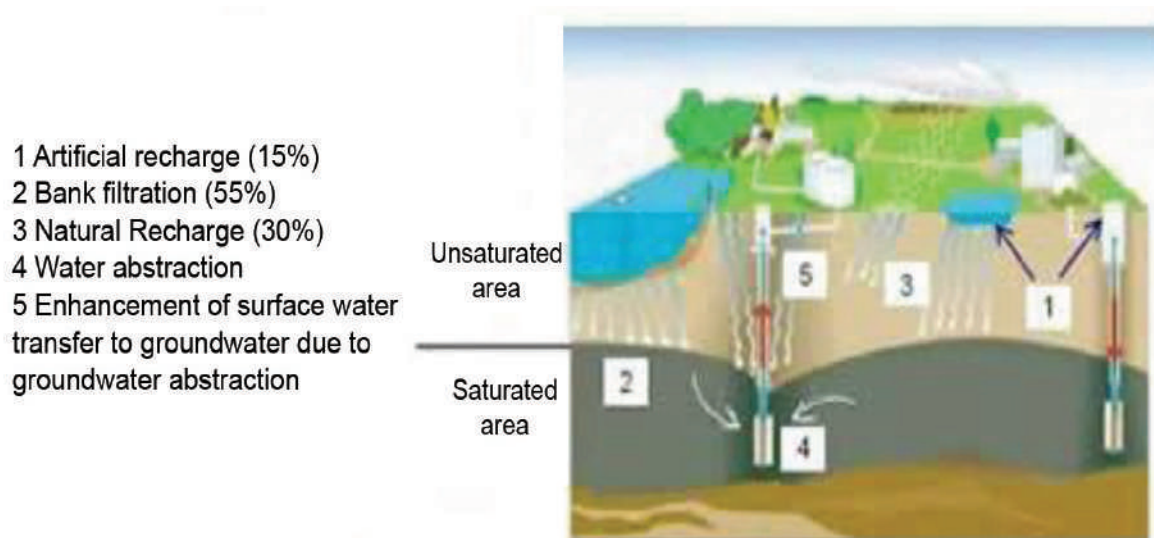

Source: Chartered Institution of Water and Environmental Management (CIWEM) webpage

Figure 7.24 Depiction of aquifer recharge in Berlin

7.3.9.5 Treated Sewage into Soil Zone and Reuse as Industrial / Agricultural Raw Water

This is referred to as Soil Aquifer Treatment (SAT). This indirectly conserves freshwater, which would have been otherwise used up in industry and agriculture. The Chennai UNDP studies established the technical and financial feasibility of treated city sewage to be applied on spreading basin and the SAT water extracted from bore wells around the periphery for cooling needs of petro-chemical industries some 20 km away is shown in Figure 7.25.

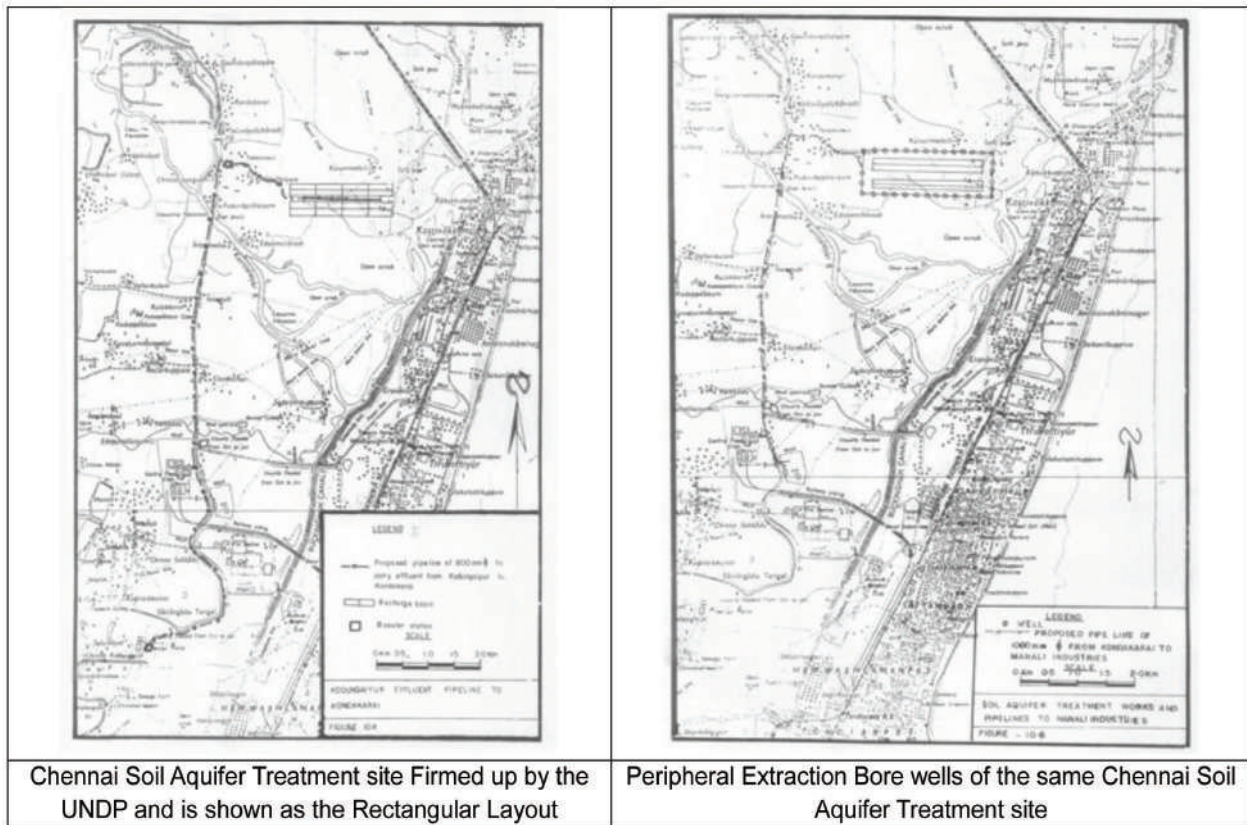

Figure 7.25 Chennai Soil Aquifer Treatment site firmed up by the UNDP

However, even after 2 decades, the proposal is yet to take shape.

This is due to public fear of such recharge getting into contact with nearby freshwater aquifers used by the population and irreversibly contaminating them.

At the same time, similar schemes are successfully operated in many parts of the world for meeting the agricultural water needs notably in Israel and USA, where the proximity to habitations issues are not arising and engineered artificial sandy tracts are constructed amidst sand dunes. The issue here is to that extent, the freshwater is conserved and hence, this is also an indirect reuse. The guiding principle for ULBs in this case will be to ensure that such SAT is prima facie only after the sewage is treated to the limits as in Table 5-20 of Chapter 5 in Part A manual and the availability of a confined aquifer for purposes other than agriculture and industry.

In any case, an assessment of potential impacts on underlying groundwater aquifers shall be determined comprehensively by extensive public consultation processes.

7.3.9.6 Treated Sewage Deep Well Injection as Seawater Intrusion Barrier

The seawater intrusion into inland coastal aquifers is a classic problem in many coastal locations. This occurs mainly due to the extraction of the freshwater from the freshwater lens beyond the safe yield limits. Once the seawater has intruded, this is not easy to be reversed. The Orange County Water District example in California, USA is perhaps the first in the world during the 1970s to demonstrate the use of tertiary treated, RO processed sewage to be blended with ground water and injected into a series of such barrier wells. It is reported that there are over 600 such wells in USA on the east and west coasts. The quality of the treated sewage before it qualifies itself to be considered for such an injection is governed by many aspects like volatile and non-volatile organic compounds, inorganic chemicals, Radionuclides and is typically with quality ranges as TDS of 44 to 416, chloride of 8 to 60, sulphate of 5 to 148, Total Organic Carbon of 1 to 3 and pH of 7 to 8 (EPA-The Class V Underground Injection Control Study, Volume 20, EPA/816-R-99-014, September 1999). Though this may be technically possible, the issue is the costs involved in the extra treatment of Reverse Osmosis (RO) and disposal of RO rejects into the sea after meeting the discharge limit in Table 5-20 of Chapter 5 in Part A manual. In addition, the issues of consistent reliability of treated quality and safeguards of system redundancies also arise. The other issue is the cost comparison between the water conserved by such sea water intrusion barrier and that produced by sea water desalination with the added cost of distributing it all over the habitation by piping. In the case of the conserved water by seawater barrier injection, it is available for the user to extract it at his convenience right in the aquifer where he lives. Thus, the guiding principles in the case of seawater barrier injection option are primarily, public acceptance and the financial sustainability besides risk mitigation to get over system redundancies.

7.3.10 Guiding Principles - Other Uses

These are already happening anyway and can be continued with appropriate safeguards, the essentials being the adequate chlorination to maintain residual chlorine of 0.5 mg/l at the point of use and the colour to be aesthetically acceptable especially while applying in public places.

7.3.11 Standard of Treated Sewage and its Uses

In addition to the guiding principles mentioned earlier the recommended treated sewage quality as in Table 7.19 (overleaf) is proposed to be achieved for the stated uses. Hence, in order to achieve the desired water quality, excess chlorination, granular activated carbon adsorption / ozonation and/or various kind of filtration including membrane are recommended. For recreational impoundments for non-human contact, residual chlorine is not required so as to protect aquatic species of flora and fauna.

However, for use in Wetlands, Wildlife habitat and Stream augmentation the recommended water quality in Table 5.2 (of Chapter 5 in Part A manual) for inland surface water discharge suffice the purpose. For uses in the construction industry like (a) Soil compaction, (b) Dust control, (c) Washing aggregate the recommended water quality in Table 5-2 for inland surface water discharge guidelines are sufficient. While for preparing concrete mix, the acidity < 50 mg/L as CaCO_3 , $\text{SO}_4 < 400$ mg/L, TDS $< 3,000$ mg/L, Chloride < 500 mg/L respectively as in IS: 456 are to be considered.

Table 7.19 Recommended norms of treated sewage quality for specified activities at point of use

Parameter	Toilet flushing	Fire protection	Vehicle Exterior washing	Non-contact impoundments	Landscaping, Horticulture & Agriculture		
					Horticulture, Golf course	Non edible crops	Crops which are eaten raw cooked
1 Turbidity (NTU)	<2	<2	<2	<2	AA	<2	AA
2 SS	nil	nil	nil	nil	30	nil	30
3 TDS	2100						
4 pH	6.5 to 8.3						
5 Temperature °C	Ambient						
6 Oil & Grease	10	nil	nil	nil	10	10	Nil
7 Minimum Residual Chlorine	1	1	1	0.5	1	nil	nil
8 Total Kjeldahl Nitrogen as N	10	10	10	10	10	10	10
9 BOD	10	10	10	10	10	10	20
10 COD	AA	AA	AA	AA	AA	30	30
11 Dissolved Phosphorous as P	1	1	1	1	2	5	5
12 Nitrate Nitrogen as N	10	10	10	5	10	10	10
13 Faecal Coliform in 100 ml	Nil	Nil	Nil	Nil	Nil	230	230
14 Helminthic Eggs / litre	AA	AA	AA	AA	AA	<1	<1
15 Colour	Colourless	Colourless	Colourless	Colourless	Colourless	AA	Colourless
16 Odour	Aseptic which means not septic and no foul odour						

All units in mg/l unless specified; AA-as arising when other parameters are satisfied;

A tolerance of plus 5% is allowable when yearly average values are considered.

7.3.12 Public Education

Education is the key to overcoming public fears about a reuse system, particularly fears that relate to public health and water quality. A broad, in-depth public relations programme and a demonstration project are especially helpful when the reuse project is the first of its kind in the state.

7.3.13 Piping and Cross-connection Control

A residual chlorine > 0.5 mg/l in the distribution system is recommended to reduce odours, slime and bacterial growth (US EPA 2004). It is crucial to be able to differentiate between piping, valves and outlets that are used to distribute treated effluent or reclaimed water and those that are used to distribute potable water. One method used for this purpose is colour-coding the components used to distribute reclaimed water not intended for drinking water. Another method is to post areas such as parks and yards with warning signs stating that the piped water there is not for human consumption. The signages should be in all the major languages of the region.

7.4 LEGAL ISSUES

The legal rights over the sale and revenue issues of reclaimed water are an emerging issue and this is addressed in Part C as a management aspect.