

CHAPTER 6: DESIGN AND CONSTRUCTION OF SLUDGE TREATMENT FACILITIES

6.1 THE APPROACH

In STP, sludge means the following.

- Primary sludge – When raw sewage is settled in a primary clarifier, the suspended solids settle down by gravity. These are drawn out from the conical floor of the clarifier. This is called primary sludge (PS). It will have mostly organic substances and also inorganic substances. If it is stored, the organic substances will undergo anaerobic reaction as in Figure 5.2. This will result in production of Methane and Hydrogen Sulphide gases.
- Secondary sludge – When the sewage is aerated in aeration tanks, biological microorganisms grow and multiply. The aerated liquid is called the mixed liquor. It is settled in secondary clarifiers to separate the microorganisms by gravity. These are drawn out from the conical floor of the clarifier. This is called secondary sludge.
- Return sludge – A major portion of the secondary sludge is returned to the aeration tank for seeding the microorganisms. This is called return sludge (RS).
- Excess sludge – A small portion of secondary sludge is wasted. This is equal to secondary sludge minus return sludge. This is called excess sludge (ES) or waste sludge (WS).
- Chemical sludge – When raw sewage or secondary treated sewage is subjected to chemical precipitation, the resulting sludge is called chemical sludge (CS).

In treatment units such as MBR, there are two optional arrangements for separating the treated sewage from the aerated mixed liquor.

In one type, the filtration membranes are submerged into the mixed liquor and the treated sewage is sucked out as the filtrate. In this case, there is no secondary sludge or return sludge. The mixed liquor itself is separately wasted as excess sludge.

In another type of MBR, the membranes are outside the aeration tank and the mixed liquor is filtered into treated sewage and secondary sludge.

The primary and excess sludge are to be further treated to produce fully inert matter which will not decay any further. Normally this is achieved by the treatment process in Figure 5.2. Here the organisms themselves are food source for new organisms till almost all organisms are reduced. This process also produces methane and hydrogen sulphide gases. The hydrogen sulphide is removed and the methane is sent to gas engines to generate electricity.

Alternatively, it can also be achieved by the treatment process in Figure 5.1, but this will need aeration and hence electrical energy is to be spent.

The typical sludge generation values are shown in Table 6-1 overleaf.

The illustrative computation of sludge generation values from ASP is in Appendix A.6.1.

Table 6.1 Typical sludge generation values

Process	kg Sludge/kg BOD removed	
	as VSS	as TSS
Primary alone	1.92	3.20
Primary and secondary as conventional ASP	0.86	1.31
Extended aeration ASP	0.26	0.93

The capacity of each sludge treatment unit is determined by considering the operating hours, sludge moisture content, retention time, etc., and is based on the solids balance of the entire sludge treatment facility. The solids balance considers the reduction due to gasification, return load from each facility and the increase due to addition of chemicals, etc. This is important for sizing the sludge treatment units.

In general, the primary and excess sludge will need a blending tank before further treatment so that the properties are made almost uniform when feeding the units. After this, if the thickened sludge is put through anaerobic digestion as in Figure 5.2 for producing Methane, it is called anaerobic digester. If it is oxidized as in Figure 5.1, it is called aerobic digester. In both cases, the digested sludge will have to be dewatered. There are many types of equipments like centrifuge or filter press or natural solar drying beds for this purpose. The solids concentrations by different treatment processes are listed in Table 6.2.

Table 6.2 Solids concentration by treatment process

Treatment process	Solids concentration (%)	
	Excess sludge	Mixed sludge
Conventional activated sludge process	0.5-1.0	1.0
Oxidation ditch process	0.5-1.0	-
Extended aeration process	0.5-1.0	-
Sequencing batch reactor process (low load)	0.5-1.0	-
Biological aerobic filtration process	-	1.0
Contact oxidation process	0.8	1.0

Source: Guideline and Manual for Planning and Design in Japan, JSWA, 2009

An illustrative solids balance in two different types of sludge treatment processes is shown in Figure 6.1 overleaf. In this figure, a pertains to direct dewatering and incineration and b pertains to the case of digestion, dewatering and incineration.

Appendix A.6.2 illustrates the calculations further.

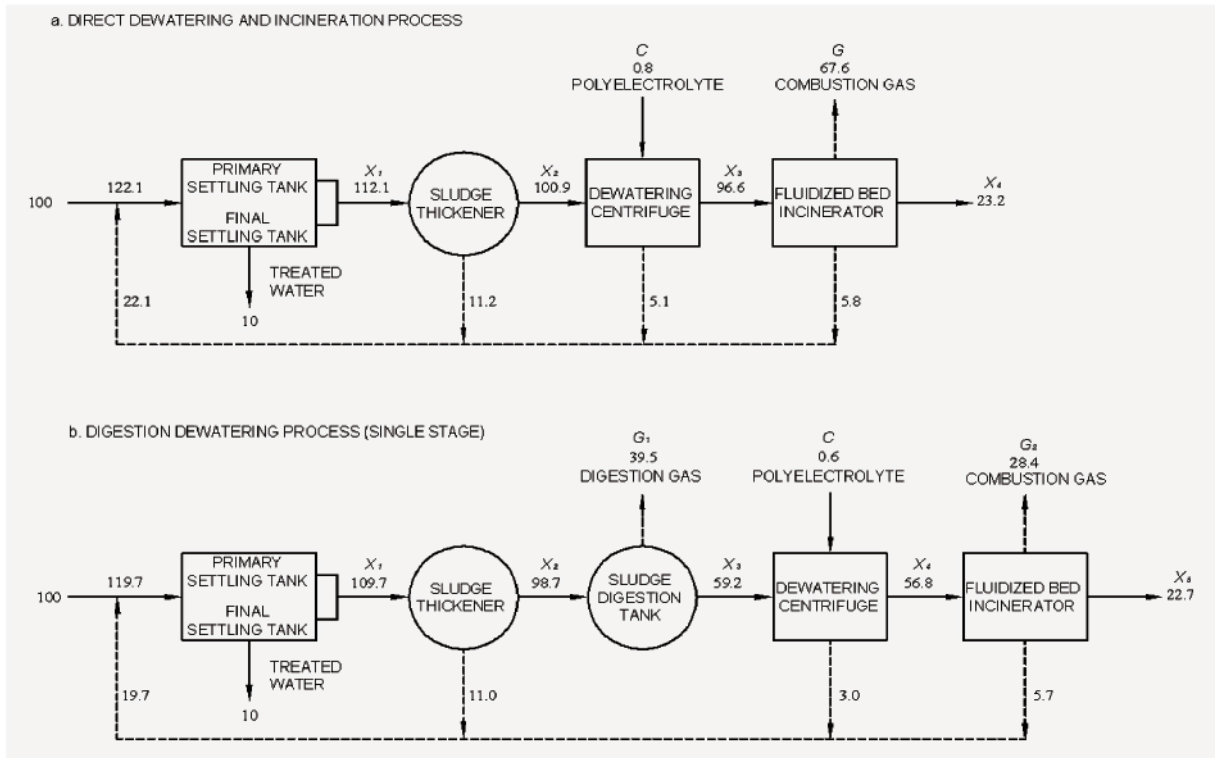


Figure 6.1 Example of solids balance (Conventional Activated Sludge Process)

In case of option a (dewatering and incineration) the solids balance occurs as follows.

- The solids load from the STP to the sludge treatment section is taken as 100.
- The solids load from the recirculation from the various units is taken as 22.1.
- Thus, the solids load entering the sludge treatment units is 122.1
- The solids load escaping in the liquid portion from the blending tank is taken as 10
- Thus, the solids load entering the sludge thickener becomes 112.1
- The solids load escaping in the liquid portion from the thickener is taken as 11.2
- The solids load leaving the thickener becomes 100.9.
- In the dewatering centrifuge, solids load from polyelectrolyte is 0.8
- Thus solids load entering the dewatering centrifuge is 101.7
- The solids load in the dewatered cake is 96.6
- The solids load of 5.1 is in the filtrate and is recirculated
- The solids load of 96.6 in the dewatered cake is sent to fluidized bed and incinerator
- Here, the solids load of 67.6 goes into the formation of combustion gases
- The solids load of 5.8 escapes in the liquid portion of the fluidized bed
- The solids load of 23.2 remains in the final product as ash.

Similarly, in the case of process b, the solids load in the final product becomes 22.7 instead of 23.2 in process a. Moreover, a digestion gas equivalent of 39.5 is gained, which in turn is a source of energy.

Thus, anaerobic digestion has its importance. The solids recovery rate varies at each stage of sludge treatment and is shown in Table 6.3.

Table 6.3 Example of solids recovery rate in each treatment stage

Process	Solids recovery rate	
Sludge thickening	Gravity thickening Centrifugal thickening Air floatation thickening (dispersed air) Gravity belt thickening	80 to 90% 85 to 95% More than 95% More than 95%
Sludge digestion	Sludge reduction ratio due to formation of gas, etc.	30 to 40%
Sludge dewatering	Pressure-type screw press dewatering Rotary pressure dewatering Belt press dewatering Centrifugal dewatering	More than 95% More than 95% 90 to 95% More than 95%
Sludge incineration	Sludge reduction ratio due to formation of gas, etc. Recovery rate	40 to 80% 80 to 90%

Source: Guideline and Manual for Planning and Design in Japan, JSWA, 2009

6.2 HYDRAULICS OF SLUDGE PIPELINES

6.2.1 Sludge Piping

Sludge piping can be by gravity or by pumping. For example, when primary sludge is drawn from clarifiers, it is sometimes by gravity and sometimes by direct suction using pumps. The friction loss in gravity pipelines and pumped pipelines are calculated as follows.

6.2.1.1 Friction losses in Gravity Sludge Pipelines

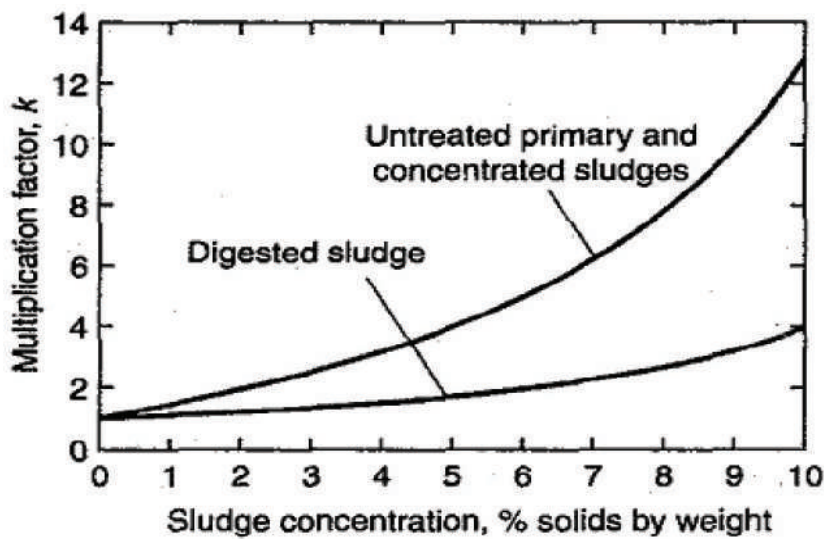
1. Calculate friction loss using Manning's formula as though it is flowing with water.
2. This friction loss is multiplied by a friction compounding factor (F) as follows
3. Estimate the solids content in the sludge (P).
4. F for undigested sludge is $= 2.88 + (0.176 \times P \times P) - (0.866 \times P)$
5. F for digested sludge is $= 1.52 + (0.041 \times P \times P) - (0.227 \times P)$
6. Allow for an additional factor of safety of 10%.

6.2.1.2 Friction Losses in Pumped Sludge Pipelines

First calculate the head loss as though it is pumping water by using the Hazen Williams formula with the value of C taken from Table 6.4 overleaf. Then, multiply the head loss by the factor k from Figure 6.2 for the given solids content (P).

Table 6.4 Hazen Williams value of C for sludge flows

Sludge solids (%)	Raw Sludge	Digested Sludge	Sludge solids (%)	Raw Sludge	Digested Sludge	Sludge solids (%)	Raw Sludge	Digested Sludge
0	100	100	4	53	78	8	33	60
1	83	100	5	47	73	9	29	55
2	71	91	6	42	69	10	25	48
3	60	83	7	37	65			



Source: Metcalf & Eddy

Figure 6.2 Head loss Multiplication Factor for Different Sludge Types and Concentrations

The equations for these curves are simplified as follows where P is the % of sludge solids.

$$k \text{ for undigested sludge} = 0.125P^2 - 0.1656P + 1.5733$$

$$k \text{ for digested sludge} = 0.0354P^2 - 0.0699P + 1.0858$$

The calculations for these friction losses are illustrated in Appendix A 6.3.

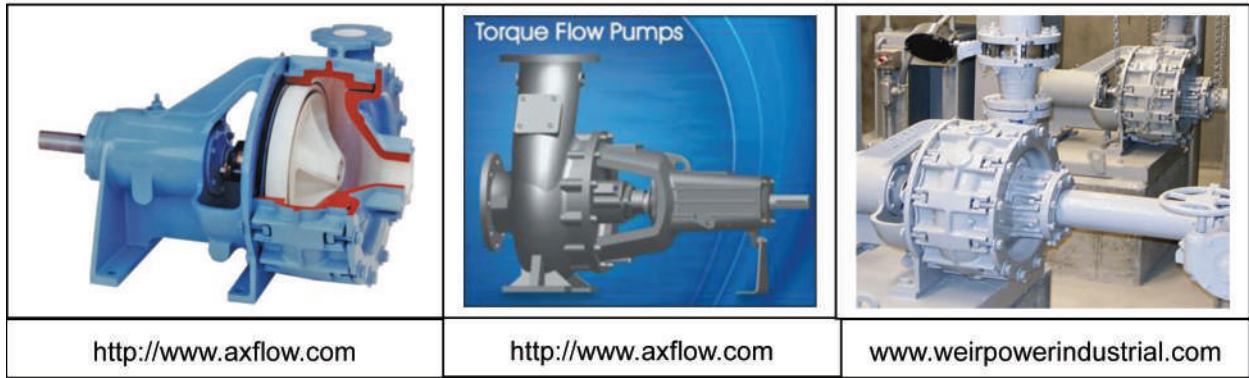
6.2.2 Sludge Pump Types and Applications

There are specific considerations to be borne in mind in the use of different types of pumps for handling sludge. The relative applicability of these is shown in Table 6.5.

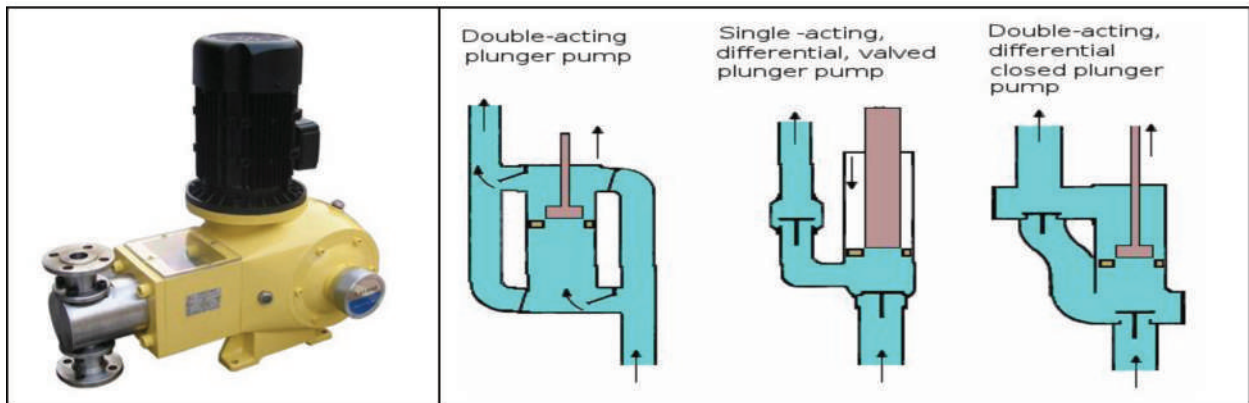
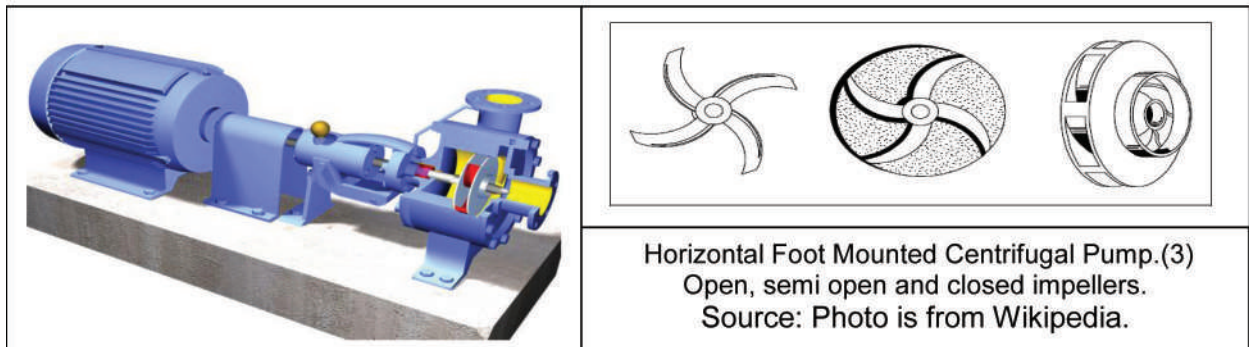
The illustrations of the internal arrangements of these are compiled in Figure 6.3 (overleaf) a to d and indexed to serial numbers in Table 6.5 for an easier visual understanding of these. In respect of impellers in centrifugal pumpsets, the rotary speed is advised not to exceed 960 rpm especially when pumping return sludge.

Table 6.5 Types of sludge pumps and their application

No	Type of Pump	Primary sludge	Return sludge	Excess sludge	Chemical sludge	Thickened sludge	Digested sludge
1	Air lift		✓	✓			
2	Archimedean screw		✓	✓			
3	Centrifugal	✓	✓	✓	✓		
4	Double diaphragm	✓	✓	✓	✓	✓	✓
5	Plunger	✓			✓	✓	✓
6	Progressive cavity	✓	✓	✓	✓	✓	✓
7	Reciprocating piston					✓	✓
8	Rotary-lobe				✓	✓	✓
9	Single diaphragm	✓					
10	Screw centrifugal	✓	✓	✓			
11	Torque flow	✓	✓	✓	✓		✓



Torque Flow Pumps-The energy is stated to be transmitted to the liquid by an induced vortex motion (11)



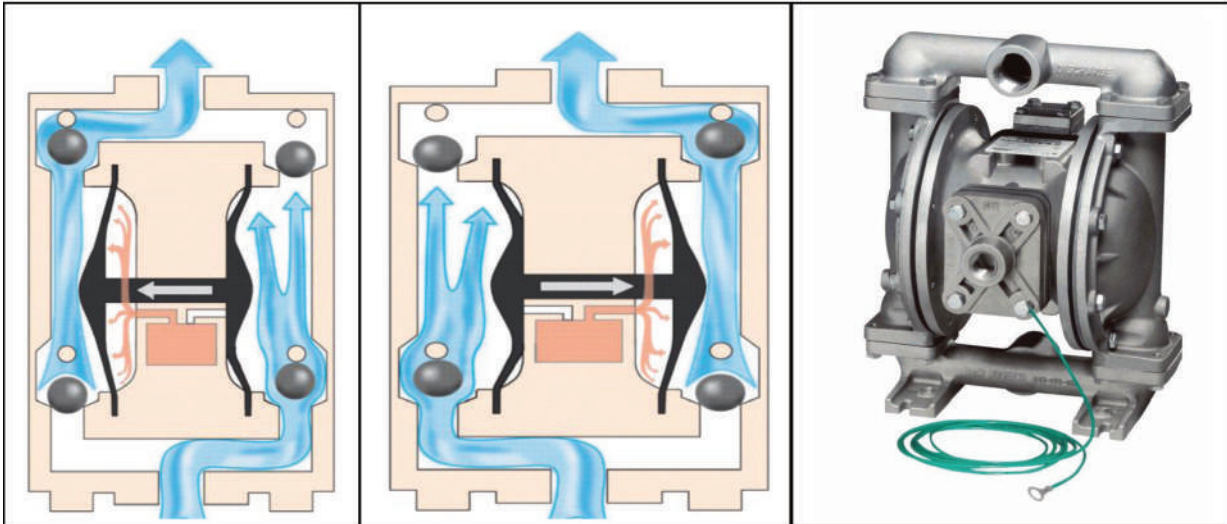
Plunger Pump- Source: Photo from a public website & drawing from <http://www.cd3wd.com>.(5)



Stator-Rotor pump or Progressive Cavity pump.(6)
Source: Drawing from <http://news.thomasnet.com>. Photo from <http://www.globalpumps.com.au>

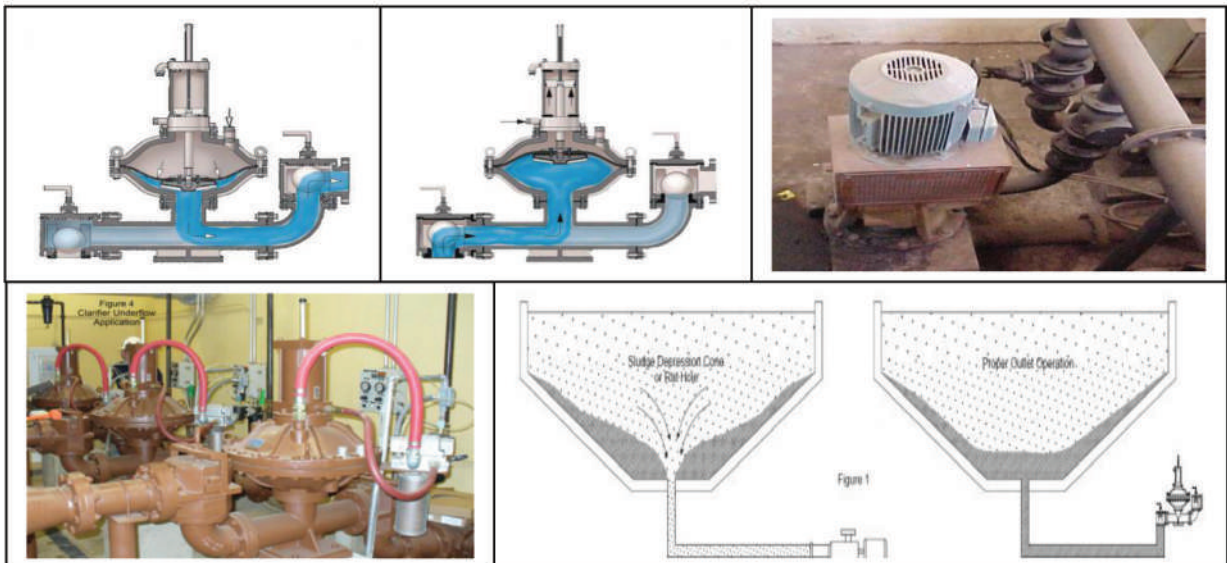
Illustrations are only for familiarity of explanations & not standalone endorsements

Figure 6.3 a Types of sludge pumps



Double acting Diaphragm pumps (4).

When the diaphragm set is pushed to the right, it displaces the sludge upwards on that side as the ball valve below prevents the sludge from going downwards. After this, when the diaphragm set is pushed to the left, it displaces the sludge already in the left compartment upwards as the corresponding ball valve prevents the sludge going downwards. At this time, sludge is drawn into the right side compartment by pushing the ball valve upwards. Thus, a near continuous sludge displacement is got. The diaphragm to and fro movement is by pneumatic. Source: Drawing from <http://www.tapflo.com>. Photo from <http://www.coleparmer.com>



Single diaphragm pump (9).

Only one diaphragm is used. Thus, sludge drawal can be intermittent. A photo of an installation during mid 1990's at the Nesapakkam STP of CMWSSB for primary clarifier sludge is shown in upper row. These suit primary clarifier sludge drawal from small sized clarifiers as the rate of sludge accumulation is much lesser than the commercially available sludge pump sets. When such pumps are started, initially the settled sludge is drawn but soon after the clarifier liquid starts flowing out. This is called as the cone of depression. These can be operated intermittently to allow sufficient accumulation of sludge each time the pump is activated. This can be done by electrical or pneumatic control. Source: From public websites & courtesy CMWSSB.

Illustrations are only for familiarity of explanations & not standalone endorsements

Figure 6.3 b Types of sludge pumps-continued

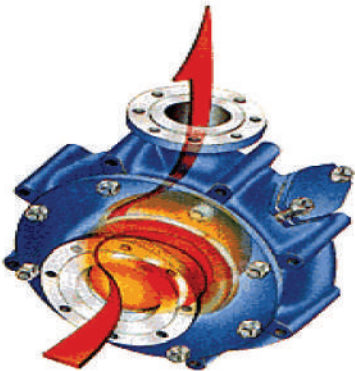
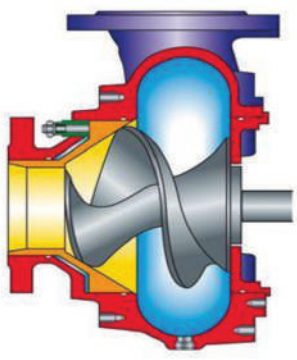


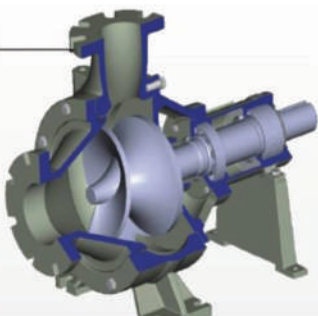

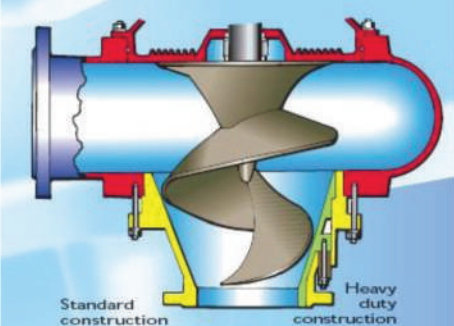

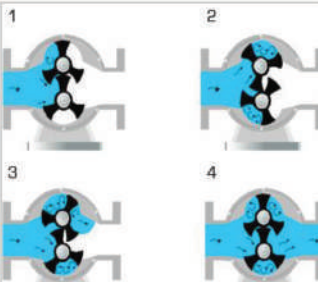


		
<p>http://www.lawrencepumps.com</p>	<p>http://www.hidrostal.co.uk</p>	<p>http://www.ib-pompen.nl/EN</p>
		
<p>http://pumps.kmspecialty.com</p>	<p>http://www.gobizkorea.com</p>	<p>http://www.chopperpumps.com</p>
		
<p>Vertical screw impeller mounting http://www.hidrostal.co.uk</p>	<p>Vertical screw centrifugal pump for primary clarifier sludge in CMWSSB Koyambedu STP in the 1990's</p>	
<p>The screw centrifugal impellers with non clog properties of the impellers (10)</p>		
		
<p>The liquid flows into the cavity and is forced through the outlet as the lobes engage. The rotary lobe pump. (8)</p>		<p>Archimedean screw pumps for (RS) at Koyambedu STP as in mid 1990's (2)</p>
<p>Illustrations are only for familiarity of explanations & not standalone endorsements</p>		

Figure 6.3 c Types of sludge pumps-continued

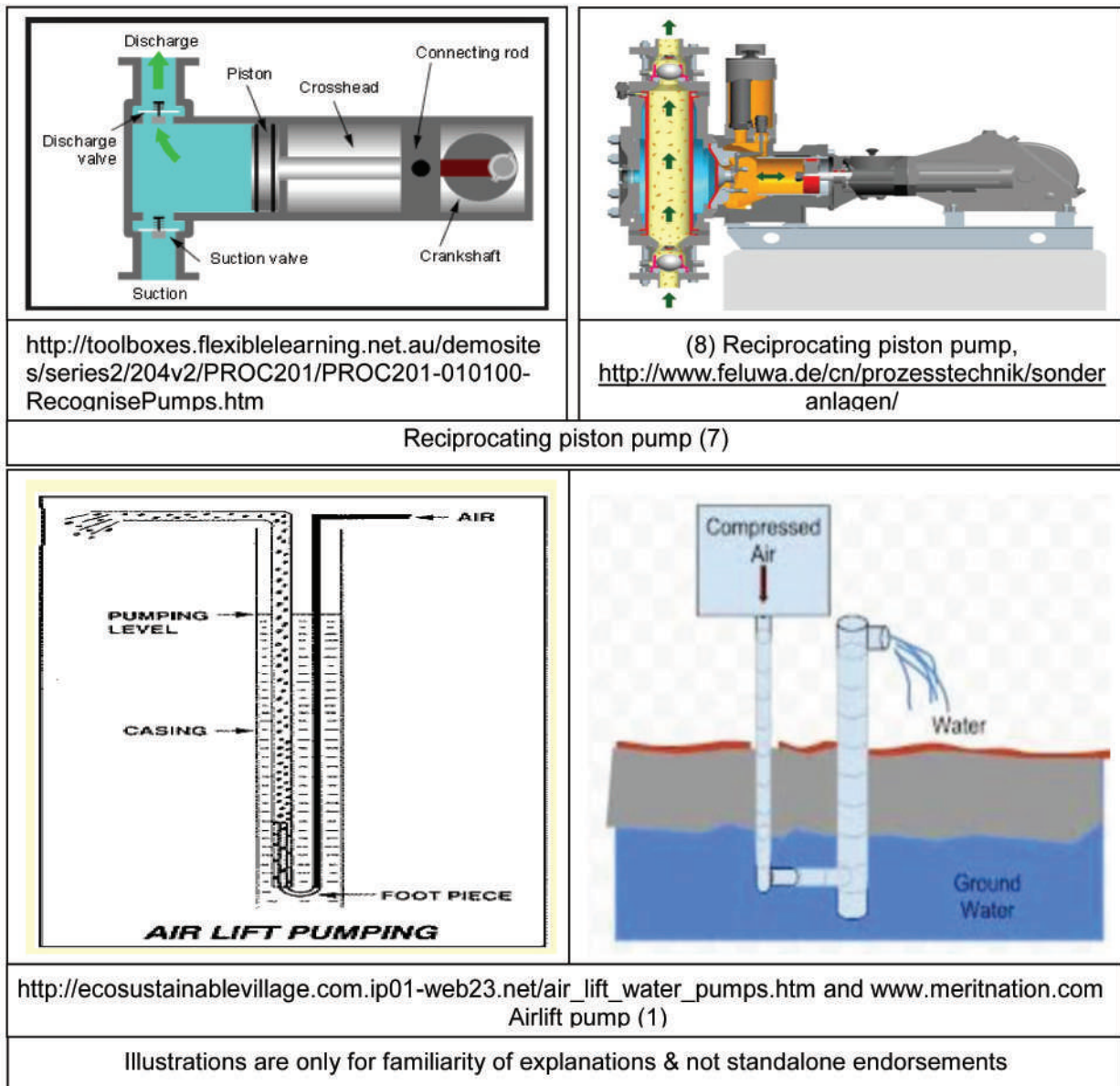


Figure 6.3 d Types of sludge pumps-continued

6.2.2.1 Centrifugal Pumps

Centrifugal pumps (as in notation 3 in Table 6.5 and Figure 6.3 a) for handling sludge must be of the non-clog type. They should be robust and should have easily accessible hand-holes for cleaning. Pumps of the macerator type impeller or additional cutters with a cutting ring whereby stringy rags and other fibrous material can get shredded are preferable. When the specific speed of the pump is low, non-clog impellers are designed with less number of blades than in impellers for handling clear liquids. In pumps of high specific speed, the mixed flow impeller should generally have wide passages. Centrifugal pumps with non-clog impellers have less efficiency than those of normal design for handling clear liquids. The rating for the drive motor has to be selected keeping this in mind. The specific speed of the pump also affects the suction-lift capability of the pump. This can be overcome by selecting a vertical centrifugal pump to be so installed that the impeller would be adequately submerged always. The impellers are best chosen as open impellers or semi open impellers or centrifugal screw impellers.

6.2.2.2 Air-Lift Pumps

Air lift pumps (as in notation 1 in Table 6.5 and Figure 6.3 d). These are used in small extended aeration plants to return the sludge and scum to the aeration tank. Small air bubbles are formed in the liquid, which makes the air-water mixing less dense to get lifted to the discharge point.

A compressor / blower supplies the air. Air-lift pumps and ejectors are pumping systems, which are though inherently inefficient, there are no moving parts inside and hence, their operation is fairly trouble-free.

6.2.2.3 Screw Pumps

These are three major variations of these as under

1. Archimedean Screw (as in notation 2 in Table 6.5 and Figure 6.3 c)
2. Stator-Rotor or Progressive Cavity (as in notation 6 in Table 6.5 and Figure 6.3 a)
3. Centrifugal Screw Impeller (as in notation 10 in Table 6.5 and Figure 6.3 c)

In the Archimedean screw pumps, the sludge enters the screw pump by a screw conveyor, which moves solids to an open impeller and lifts them to the point of discharge. The submerged lower bearing is of the enclosed and sealed type and the upper bearing is usually grease-lubricated with anti-friction bearing. The discharge rate plotted on x axis and head plotted on y axis will be a horizontal line in these pumps. In general, these are ideal for return sludge because it permits incidental additional aeration over the screws and rotates at gentle speeds of just about 20 or 30 rpm. They also permit visual inspection of the sludge.

A variation of the screw pump is the stator rotor or progressive cavity pump. The pumping element is a helical rotor of steel. It has a compressible stator or lining inside a cast iron body and is contoured to mesh with the helical rotor. Although the pump has some self-priming capability, the rotor must never run dry against the rubber stator. The pump can pump forward or reverse depending upon the direction of rotation. They are not advised for return sludge as the live organisms will be squeezed in the stator and rotor.

The centrifugal screw impeller has a shape of an Archimedean screw with widening diameter of each successive spiral. They can be mounted both vertically and horizontally. The impeller weight is usually heavier as compared to other screw pumps. They however, have the advantage of a truly non-clog design and are especially suited for sludge drawal from primary clarifiers because the possible fibrous materials or rags etc which might get into the clarifier sludge will be gliding over the impeller screw and are pushed out without choking the impeller. They are also useful in return sludge pumping as the live organisms do not get hit at the impeller or casing surfaces.

6.2.2.4 Reciprocating Plunger

Plunger type pumps (as in notation 5 in Table 6.5 and Figure 6.3 a) have a plunger reciprocating in a cylinder. A pump can have one or more plungers connected to common crankshaft, thereby obtaining arrangements called simplex, duplex, triplex, etc. Their capacities are of the order of 150 to 250 rpm per plunger. The pump speeds should be between 40 to 50 rpm.

They are self-priming and can usually work well with suction-lifts up to 3m. The suction-lift capability depends on the design of the pump, especially the suction valve. The pumps can develop high heads and are hence, suitable where accumulation of grease in piping can cause progressive increase in head.

However, if the delivery piping is likely to get choked, the pumps may develop very high pressures and this can cause a burst. A relief valve is provided to protect the pump in case of a clogged delivery piping after each use. The pump should be flushed so that no solids settle in the cylinder which could damage the pump during the next start. The suction and delivery valves are the main source of trouble. The valves should be easily accessible for quick cleaning, in case the valves fail to seat properly.

6.2.2.5 Diaphragm Pumps

The diaphragm pumps (as in notation 4 & 9 in Table 6.5 and Figure 6.3 b) have a flexible diaphragm, usually of rubber and actuated by a reciprocating movement. They can be either a single diaphragm or double diaphragm type.

The diaphragm is fastened peripherally to the casing, which also houses the suction and delivery valves. The interesting feature of the diaphragm pumps is that the components of the reciprocating mechanism, which are most prone to wear, are isolated from the path of the sludge. Pneumatic or hydraulic drives can also be employed for the reciprocating movement. These are suited for intermittent pumping of primary clarifier sludge.

6.2.2.6 Torque Flow Pumps

The torque flow pumps (as in notation 11 in Table 6.5 and Figure 6.3 a) can handle solids up to the full delivery bore size on the discharge side. The energy imparted to the liquid is by the principle of hydro-dynamic liquid coupling. The shape of the impeller helps to generate the necessary swirl inside the casing and this acts as a pumping impeller component.

It is stated as a non-clog concept in pumping. In essence, the sludge that is drawn on the suction side is made to pick up the energy and glide around the inside of the volute before going out with the delivery head.

6.2.2.7 Rotary Lobe pumps

Rotary Lobe Pumps (as in notation 8 in Table 6.5 and Figure 6.3 c). Liquid flows around the interior of the casing, but without making contact. This is prevented by external timing gears located in the gearbox. Pump shaft support bearings are located in the gearbox, and since the bearings are out of the pumped liquid, pressure is limited by bearing location and shaft deflection.

As the lobes come out of mesh, they create expanding volume on the inlet side of the pump. Liquid flows into the cavity and is trapped by the lobes as they rotate. Liquid travels around the interior of the casing in the pockets between the lobes and the casing. The liquid does not pass between the lobes. The meshing of the lobes forces the liquid through the outlet port under pressure.

6.2.2.8 Operational Problems

The gases like Hydrogen Sulphide often get liberated when the sludge, particularly the digested sludge, is subjected to suction. This hampers the proper operation of the pump. The pumps should be installed, as far as possible, with positive suction. If the suction arrangements are improperly designed, a vortex-cone or sink developing in the sludge blanket will cause the watery sludge or supernatant to be drawn instead of the sludge.

The suction pipe should not be too long, nor should the pumping be too long or too fast. It is better to pump more often than at reduced speed. When a pump is equipped with variable speed drive, it can be started at a relatively high speed and the speed can then be reduced.

Sludge from two settling tanks should not be connected to the suction of a common pump. The settling tank with the thinner sludge will get pumped and the thickened sludge in the other tank will not get pumped. Similar problem will happen, if the suction lines from the two tanks will have differential frictional losses.

The tank with higher frictional loss in its suction piping, which may be because of more length or because of choking, will not get pumped. The capacity of sludge pumps is required to be regulated according to the sewage load. Further, variable speed drives are more appropriate for regulation because delivery valves present in the sludge pumping system makes the system inefficient and prone to trouble.

6.2.2.9 Requirement of Standby Units

The number of pumping units required including the standby is determined by several factors like the particular function involved, the size of the plant and the arrangement of the units, especially having combination of more than one function. A standby capacity of 16 hours in 2 shifts, 7 days working 100% standby is recommended wherever mechanical thickening and mechanical dewatering is practised. However, these standby units are not required for gravity thickening with picket fence. Since sludge pumping is an important function, standby pumps are provided in equal numbers or by such arrangement that permits dual duty. The scum is usually mixed with primary sludge and pumped.

6.2.2.10 Pump Appurtenances

The performance of the sludge pumps can be more efficient and their control can be better if various appurtenances such as air chambers, sampling devices, measuring devices, valves, gauges are incorporated in the system and facilities such as revolution counters, gland seals, time clocks, etc., are kept available at the plant.

6.2.2.10.1 Air Chamber

An air chamber of adequate size is necessary for all plunger type sludge pumps on the discharge side of the pump as well as the suction side of the pumps, particularly where positive suction head exists. Such chambers absorb the shock of plunger pump pulsations.

6.2.2.10.2 Revolution Counter

Plunger-type sludge pumps should be equipped with revolution counters or integrating recorders to help the operator to determine the quantity of sludge pumped in duplicate pump installations. These pumps aid in equalizing the service and wear of each pump.

6.2.2.10.3 Gland Seals

In the case of centrifugal pumps, external sealing is provided in the stuffing box to prevent the ingress of air into the pump. The external sealing may be grease seal or water seal. The water seals are preferable, as it helps the grit and dirt to be washed away. The water to the water-seal has to be potable water. However, the connection of potable water should not be taken directly from supply lines.

6.2.2.10.4 Valves

When a dry pit pump has positive suction head in the wet well, there should be an isolating valve. Usually a gate-valve or a knife edge valve on the suction line, is used to facilitate isolating the pump for maintenance. On the delivery side of centrifugal pumps, a non-return valve is necessary, so that the pump would not experience the back-pressure from the delivery head when the pump has to be switched off. To minimize the pressure-drop across the valve during the running of the pump, the non-return valve should be of the swing-check or the ball-check type.

To avoid water-hammer, which is likely to be caused by the closure of the valve, the valve may be provided with an anti-slam device, either of the lever and dead-weight type or of the spring-loading type or of the dash pot type. Dual check valves are sometimes used, which gives more consistent operation and facilitates for the use of the pump as metering device. All the valves may be provided with drain plugs. In larger size plants, where pumps may run in parallel operation with different permutation of the standbys, isolation valves are required to isolate those pumps that may be idle. All valves should preferably be of the rising stem type, since they offer the advantage of visual indication of the valve-position.

For exterior underground locations, gate valves are generally used. Underground sludge valves should be avoided as far as possible by taking advantage of the hydrostatic pressure for sludge withdrawal through a slant pipe and valve.

6.2.2.10.5 Gauges

Pressure gauges should be provided on both the suction and delivery sides. For pumps having suction lift, the gauge on the suction side should be a composite vacuum-pressure gauge. The gauges should be with a cast iron bowl and an oil-resistant rubber diaphragm to keep the sludge away from the finer working parts of the gauges.

6.2.2.10.6 Sampling Devices

All sludge pumps shall be provided with sampling taps either within themselves or in the piping adjacent to the pump. These are usually plug valves, normally of size NS 40. Plug valves are simple and easy to operate for taking samples.

6.2.2.10.7 Washouts and Drains

Washout or flushing arrangements are provided for sludge pumps to facilitate easy and rapid cleansing. The drains on the pump body should be of ample size to ensure release of pressure and drainage of the liquid. The outlet of the drain should be connected to an adjacent floor drain to keep the floor clean.

6.2.2.10.8 Time Clocks

Time clocks, wired across the magnetic starters or motor leads of sludge pumps can be a valuable help to the operators. They help to keep an accurate record of the time taken to run the pump for observing the preventive maintenance schedules in respect to attending to the lubrication, equalization of wear and tear, etc.

6.2.2.10.9 Measuring Devices

While time clocks and counters are adequate for small plants, supplementary flow-metering arrangements, such as flow tubes with flushing provisions are used in large plants for measuring and recording the quantities of sludge handling. Magnetic meters are more suitable for sludge metering. Sludge density meters to be installed in the return sludge line of plants for more than 1 mld capacity and an advisory for small plants so that they can install if they want in STPs of less than 1 mld capacity.

6.2.2.11 Pump Drive Equipment

The prime movers for the pumps are usually the electric motors, which have been discussed in detail in Section 5.12.3 of Chapter 5. It is desirable to use flame-proof motors. I.C. engines can be used for standby services in the case of failure of electric power. Again, the I.C. engine is better used as prime mover for a standby generator than as a prime mover for the pump, because the standby generator can then provide the power for lighting and ventilation facilities. Gas engines using sludge gas as fuel would help not only as a standby power supply facility, but also as an effective energy conservation in the operation of the plants.

6.2.3 Physical Features of Sludge Piping for Pumps

After selecting the type of pump, the next important thing is to design the suction and delivery pipelines. The design is based on the sludge pumping rate, the velocity in the pipeline, a layout with minimum bends and a material that is corrosion and abrasion resistant.

Sewage sludge flows like a thin plastic material and hence, the formulae for the flow of water are not applicable. The velocity of flow should be in the critical range above the upper limit of the laminar flow and below the lower limit of the turbulent flow, in order to avoid clogging and deposition of grease, so that the application of the hydraulic formulae for flow of water becomes permissible. In general, velocities between 1.5 and 2.5 m/s are to be considered.

The diameter of sludge pipes is important to permit cleaning. Where sludge is drawn intermittently as in primary clarifiers, it is advisable that it should be at least 150 mm for suction drawal and 200 mm for gravity drawal.

Provision shall be mandatorily provided for periodical flushing of the pipeline. This can be made by inserting a “Y” branch double flanged special and closing the free side of the flange by a knife edge valve and then another double flange short pipe with blank flange. For flushing the pipeline, first the sludge pump shall be stopped or if it is by gravity, the delivery side valve should be closed. Thereafter, the delivery side of the service line of the plant air compressor or a branch line from the final treated sewage pump shall be suitably connected to the free flange of the short pipe after removing the blank flange. Thereafter, the knife gate valve shall be slowly opened and the air or treated sewage gradually allowed to dislodge any choked sludge back into the clarifier.

For smaller STPs the single diaphragm sludge pump arrangement can be used to advantage. In order to take care of thin sludge to flow by gravity for short distances within the STP, a 3% or greater slope should be adopted.

The suction and discharge piping shall be arranged in such a way that their lengths are as short as possible, straight and with minimum bends. Adequate provision shall be made to facilitate cleaning. Large radius elbows and sweep tees are usually adopted for change in direction. High points should be avoided, as far as possible, to prevent gas pockets. Suitable recess and sleeves are usually provided for all pipes passing through masonry. Double-flanged pipes are usually adopted for sludge lines with at least one 45 degrees double flanged joint in the line for easy dismantling and reassembling. Valves shall be provided at selected locations to clean the lines.

6.2.4 Adverse Effects of Heavy Metals and Sludge Components on Unit Processes

Heavy metals may have adverse effects upon the sludge digestion which is a biological process. If concentrations of certain materials (e.g., ammonia, heavy metals, light metal cations and sulphide) increase significantly, they can create unstable conditions in the anaerobic digester. A shock load of such materials in the plant influent or a sudden change in digester operation (e.g., overfeeding solids or adding excessive chemicals) can create toxic conditions in the digester.

Typically, excess concentrations of such toxicants inhibit methane formation, which leads to volatile acid accumulation, pH depression and digester upset. Depending on the concentration and type of toxics, the effect can be acute (e.g., instant process failure) or chronic (e.g., depressed performance). Chemicals can control the concentrations of dissolved toxics (e.g., using iron salts to control sulphide). A sound monitoring and control programme, and an understanding of toxic agents, can greatly improve the design of mitigation systems.

6.2.5 Sludge Digestion or Stabilization Requirements including Appropriate Pathogen and Vector Attraction Reduction

Processes that significantly reduce pathogen levels in sludge include aerobic and anaerobic digestion, air drying, alkaline stabilization and composting. Processes that further reduce pathogens include Beta or Gamma ray irradiation, composting, heat drying, heat treatment, pasteurization and thermophilic anaerobic digestion.

The STPs typically use the following four processes to reduce pathogen level in sludge.

- 1) Heat drying
- 2) Aerobic and anaerobic digestion
- 3) Composting
- 4) Alkaline stabilization

The pathogens in sludge pose risk only if there are routes by which these come into contact with humans or animals. The route for transport of pathogens is transmission by vectors such as insects, rodents and birds. These are capable of transmitting a pathogen from one organism to another either mechanically (by simply transporting the pathogen) or biologically by playing a specific role in the life cycle of the pathogen. Suitable methods for measuring vector attraction directly are not available.

Vector attraction reduction is accomplished by employing one of the following:

- i. Biological processes which breakdown volatile solids and thereby reducing the available food nutrients for microbial activities and odour potential
- ii. Chemical or physical conditions that stop microbial activity
- iii. Physical barriers between vectors and volatile solids in the sewage sludge

6.2.6 Return Flow Treatment Requirements

The thickened centrate, digested supernatant liquor, dewatered filtrate, etc., generated in each sludge treatment process are known by the general name “return flow” and this return flow is generally returned to the STP and treated. In this case, the water quality that requires to be checked in the return flow generated in each treatment stage is as follows:

- 1) Thickening: SS, nitrogen, phosphorous
- 2) Anaerobic digestion: Nitrogen, phosphorous, COD
- 3) Dewatering: although the items vary depending on the treatment process up to dewatering, the digestion process exits nitrogen and phosphorus

In a STP that treats only sludge generated from individual treatment plants, the return flow is generally assumed to have no adverse effect when designing the STP considering the return flow loads generated from the sludge treatment. However, when temporal changes in quantity or quality of the return flow are large, measures should be adopted such as installing a return flow storage tank, temporarily storing the return flow and returning the averaged return flow to the sewage treatment facilities. The return destination is taken as the grit chamber or the primary settling tank on the influent side, but in case of the former, considerations are necessary to sample influent sewage that does not include the return flow.

Sometimes, the return flow may be independently treated as a method of reducing the return flow load circulating between the STP and the sludge treatment facilities. When sludge is received from another treatment plant and anaerobic digestion is being performed, the BOD, SS, COD, nitrogen and phosphorus loads of the return flow will increase.

Therefore, independent return flow treatment or some other form of pre-treatment and returning to the STP may be considered. There are two methods for independently treating return flows so that the treated water quality is approximately the same as that of the influent and returning it to the secondary treatment facility; and the method of treating it as far as possible by direct discharge. However, the method should be decided after making an overall judgment considering economics including treatment cost and the stability of treated water.

6.2.7 Sludge Storage Requirements

Sludge storage tanks are installed when sludge is to be stored or transferred between various facilities when the sludge withdrawn intermittently from primary settling tank, secondary settling tank and gravity thickener is to be continuously loaded to the post treatment stages.

These tanks may sometimes be installed when sludge has to be stored for a comparatively long period such as when sludge dewatering equipment needs to be operated only during day time and sludge generated in a small-scale facility needs to be stored, or sludge has to be temporarily transported. A sludge storage tank should be decided as described below.

6.2.7.1 Capacity of Sludge Storage Tank

Tank capacity should be decided considering the amount of sludge loaded into and drawn off from the tank, the sludge transfer process (continuous, intermittent), and the storage time required for O&M.

6.2.7.2 Structure

Sludge storage tanks are generally located underground; therefore, reinforced concrete structure should be adopted as watertight structure with no permeation of groundwater.

Corrosive gases such as hydrogen sulphide may be emitted and hence, anti-corrosive coating should be applied on the internal surface of the tank to protect from corrosion.

6.2.7.3 Number of Tanks

A minimum of two tanks of each 50 percent capacity may be provided.

6.2.7.4 Agitator

When sludge is stored for a long period, it will decompose in accordance with Figure 5-2 in chapter 5. In this process, scum will form and sediments will form at the bottom. Hence, air should be blown as necessary or an agitator or scum skimmer should be installed.

6.2.7.5 Odours in Tank and Deodorization

In principle, odours should be captured and deodorized to prevent leakages.

When air agitation is used, the suction capacity should be greater than the blowing capacity.

6.2.8 Methods of Ultimate Disposal

The methods of ultimate disposal are as follows:

1. Dewatered sludge reused as it is in agricultural land or in landfills.
2. Agricultural land applications have the advantages of simplicity and low costs, but there are safety issues such as bacteria; therefore, introduction of a digestion stage and stabilization of quality are recommended. There are also issues related to generation of odours and transportation issues in this treatment process; thus, considerations for the surrounding environment are necessary. Special measures are necessary when sun-dried beds are adopted.
3. Method in which dewatered sludge is processed and used in agricultural land as fertilizer; sludge is dried in granular form by mechanical drying or solar drying or by composting to improve safety and handling ability. Hence, this form is recommended for agricultural land applications.
4. Dewatered sludge is incinerated or fused, and ash or slag is effectively used as building material, etc., or used as landfills.
5. Thermal or solar dried sludge can be used as low-grade fuel with the concurrence of PCB

6.2.9 Back-up Techniques of Sludge Handling and Disposal

It is necessary to prepare the back-up techniques of sludge handling and disposal for the case where sludge treatment and disposal cannot be performed due to failure of sludge treatment facilities. The following back-up techniques may be considered.

1. Storage of liquid sludge in vacant or unoccupied settling tanks, etc. and storage of solid sludge in open space at STPs if available.
2. Transportation of liquid sludge using a tanker lorry to other STPs.
3. Preparation of the mobile dewatering machine.

6.3 SLUDGE THICKENING

This is to thicken the concentration of sludge solids generated in the clarifier to make sludge digestion and sludge dewatering more effective. Sludge to be thickened may be primary sludge or combined sludge from primary and excess sludge. Thickening may be broadly classified into three types namely, gravity, centrifugal and floatation. The floatation can further be dissolved-air floatation or dispersed-air floatation. When the thickening of sludge is inadequate, the filtrate from dewatering will have large amounts of suspended solids returning to the STP and affect the water quality. Hence, excess sludge is increasingly being mechanically thickened using centrifugal thickening machines or floatation thickeners. Moreover, when performing sludge treatment for sludge collected from various STPs, sludge with varying properties is likely to be treated; therefore, forced sludge thickening process such as by using mechanical thickening equipment is indispensable.

Degritting and debris removal equipment preferably be installed as the pre-treatment process before thickening unless the STP itself has such facilities in the raw sewage stage.

6.3.1 Gravity Thickening

Gravity thickening is the most common practice for concentrating the sludge. It is adopted for primary sludge or combined primary and activated sludge, but is not successful in dealing with excess sludge independently. Gravity thickening of combined sludge is not effective when excess activated sludge exceeds 40% of the total sludge weight. In such cases, other methods of thickening of the excess activated sludge have to be considered. Gravity thickeners are either continuous flow or fill and draw type, with or without addition of chemicals. Use of slowly revolving stirrers improves the efficiency. Continuous flow tanks are deep circular tanks with central feed and overflow at the periphery. They are designed for a hydraulic loading of 20,000 to 25,000 lpd/m². Loading rates less than 12,000 lpd/m² are likely to give too much solids to permit this loading hence, it is necessary to dilute the sludge with plant effluent and it is referred to as dilution water. Better efficiencies can be obtained for gassy sludge by slow revolving stirrers.

The surface loadings for various types of sludge are given in Table 6.6 along with solid concentration of various types of thickened sludge.

Table 6.6 Surface loadings and solids concentration

Type of Sludge	Solids Surface Loading (kg/day/sqm)	Thickened Sludge Solids Concentration (%)
Separate Sludge		
Primary	90 - 140	5 - 10
Activated	25 - 30	2.5 - 3.0
Trickling filter	40 - 45	7 - 9
Combined Sludge		
Primary + activated	30 - 50	5 - 8
Primary + trickling filter	50 - 60	7 - 9

Continuous thickeners are mostly circular with a side water depth of about 3 m. Concentration of the underflow solids is governed by the depth of sludge blanket up to 1m beyond which, there is very little influence of the blanket. If underflow solids concentration is increased with increased sludge detention time, 24 hours is required to achieve maximum compaction. Sludge blanket depths may vary with fluctuation in solids production to achieve good compaction. During peak conditions, lesser detention times will have to be adopted to keep the sludge blanket depth sufficiently below the overflow weirs to prevent excessive solids carryover. It is necessary to ensure provisions for (a) regulating the quantity of dilution water needed; (b) adequate sludge pumping capacity to maintain any desired solids concentration, continuous feed and underflow pumping; (c) protection against torque overload and (d) sludge blanket detection.

6.3.1.1 Capacity

The tank capacity is decided considering the following:

- 1) Consider solids load as 60 to 90 kg.dry solids / (m².d) approximately.
- 2) Consider effective water depth as approximately 4m.

6.3.1.2 Shape and Number

The shape and number of tanks are decided considering the following:

1. In principle, the tank should be of circular shape.
2. Consider the slope of the tank bottom as follows:
 - i. A slope as 5/100 or greater if a sludge scraper is installed.
 - ii. If no sludge scraper is installed, assume hopper system and take a slope of 60 degrees or greater with respect to the horizontal.
3. In principle, the number of tanks should be two or more tanks.

6.3.1.3 Structure

The structure of the tank is decided after considering the following:

1. In principle, the tank should be of RCC with consideration given to anti-corrosion.
2. Provide sludge inlet pipes, sludge draw-off pipes and overflow weirs.

6.3.1.4 Appurtenances

Decide the appurtenances after considering the following:

1. The speed of the sludge scraper should not agitate the deposited sludge
2. In principle, draw off the sludge using a pump.
3. Use ductile or cast iron pipe as far as possible.
4. Provide backwash pipes at appropriate locations considering that the sludge draw-off pipe may be blocked.
5. If multiple tanks are present, install the distribution tank at the front end.
6. Install a scum skimmer on the liquid surface of tank. Take steps to ensure that the overflow weir can be cleaned.
7. If necessary, install de-gritting and debris removal equipment before thickening.
8. If necessary, cover the tank and install ventilation and deodorization equipment as dealt with in Chapter 5.

6.3.2 Centrifugal Thickening

Thickening by centrifugation is applied only when there is space limitation or sludge characteristics will not permit the adoption of the other two methods. This method involves high maintenance and power costs. Centrifuges employed are of either disc or solid bowl type. Disc centrifuges are prone to clogging while the latter gives a lower quality of effluent.

6.3.2.1 Centrifugal Thickener

1. In principle, two or more thickeners should be installed.
2. Take the water content of thickened sludge as 96% approximately, and the standard solids recovery rate as 85% to 95%.
3. Use durable material.

6.3.2.2 Sludge Feed Pump

Decide the sludge feed pump after considering the following:

1. Select a pump with adequate capacity.
2. Install separate pumps for each centrifugal thickener.

6.3.2.3 Appurtenances

Decide the appurtenances after considering the following:

1. If necessary, install de-gritting and debris removal equipment before thickening.
2. Install sludge feed tank.
3. Install thickened sludge storage tank.
4. Install water supply system for internal cleaning of the centrifugal thickener and for cooling the bearing.
5. Formulate measures against vibration and noise. Install ventilating equipment and deodorization equipment, if necessary.
6. Install equipment for controlling the water content of thickened sludge.
7. If necessary, install chemical dosing equipment.

6.3.3 Air Floatation Thickening

Air floatation units employ floatation of sludge by air under pressure or vacuum and are normally used for thickening the waste activated sludge. These units involve additional equipment, higher operating costs, higher power requirements, and more skilled maintenance and operation. However, the removal of oil and grease, solids, grit and other material as also odour control are distinct advantages.

In the pressure type floatation units, a portion of the subnatant is pressurized from 3 to 5 kg/cm² and then saturated with air in a pressurization chamber. The effluent from this is mixed with influent sludge immediately before it is released into the flotation tank. Excess dissolved air then rises up in the form of bubbles at atmospheric pressure attaching themselves to particles which form the sludge blanket. Thickened blanket is skimmed off while the un-recycled subnatant is returned to the plant.

The vacuum type employs the addition of air to saturation and applying vacuum to the unit to release the air bubbles which float the solids to the surface.

The efficiency of air floatation units is increased by the addition of chemicals like alum and polyelectrolytes. The addition of polyelectrolytes does not increase the solids concentration, but improves the solids recovery rate from 90% to 98%.

6.3.3.1 Dissolved-air Floatation Thickening

Dissolved-air floatation thickening refers to the process of making fine air bubbles stick to sludge particles, to reduce the apparent specific gravity of sludge with respect to water, and make the particles buoyant so as to separate solids and liquids. Systems include partial-flow pressurization, full-flow pressurization and return flow pressurization.

It is important that the appropriate size of fine air bubbles is generated and these attach effectively to sludge particles. The attachment of bubbles may be easy or difficult depending on the physical and chemical characteristics of the surface of particle; sometimes, addition of coagulant may be necessary depending on the particle. Dissolved-air floatation thickening equipment consists of dissolved-air floatation tank, pressurization pump and air dissolution tank.

Partial-flow pressurization is not used much for sludge treatment since the air dissolution level is low compared to other methods because a part of the loaded sludge is directly conveyed to the air dissolution tank by the pressurization pump.

Full-flow pressurization system is simpler than the return flow pressurization system, since the complete volume of loaded sludge is sent to the air dissolution tank by the pressurization pump. However, since there is a limit to air solubility, it is mostly used when the concentration of loaded sludge is comparatively small.

Return flow pressurization is one in which loaded sludge and pressurized water are mixed by an ejector. The power of the sludge pump can be reduced, but its suitability depends on the properties of sludge.

In recent years, the system of mixing and pressurizing loaded sludge in pressurized sewage (mixing under pressure) and the system of mixing loaded sludge immediately after reducing the pressure of pressurized sewage (mixing under reduced pressure) are being used. The return flow pressurization system uses centrate or treated water.

6.3.3.1.1 Capacity

The floatation tank capacity is decided considering the following:

1. Consider the solids load as 100 to 120 kg dry solids / (m².d) and the standard solids recovery rate as 85% to 95%.
2. Consider the standard effective depth of tank as 4.0 m to 5.0 m.

6.3.3.1.2 Shape and Number

The shape and number of floatation tanks are determined considering the following:

1. The shape of the tank is to be circular, square or rectangular.
2. In principle, the number of tanks should be two or more tanks.

6.3.3.1.3 Structure

The structure of floatation tank is decided considering the following:

1. The material should be watertight reinforced concrete or equivalent.
2. To adjust the water surface, install weir and other equipments.

6.3.3.1.4 Sludge Remover and Sludge Scraper

A froth remover that removes the froth and a sludge scraper that scrapes and collects the settled sludge are installed in the floatation tank.

6.3.3.1.5 Pressurizing Pump

Decide the pressurizing pump after considering the following:

1. Select discharge pressure in the range of 0.2 to 0.4 MPa (2 to 4 kgf/cm²).
2. The capacity is decided as follows:
 - i) In case of the partial-flow pressurization, consider the concentration of sludge and pressure so that the desired air-solid ratio is obtained.
 - ii) In case of the full-flow pressurization, take the loaded sludge amount.
 - iii) In case of the return flow pressurization, take the loaded sludge amount and decide the capacity after considering the concentration of sludge and pressure.

6.3.3.1.6 Air Dissolution Tank

The structure of air dissolution tank is decided considering the following:

1. The structure should comply with pressure vessel construction standards, and should be capable of giving good air dissolution efficiency.
2. The capacity should be decided based on a retention time of about 2 minutes.
3. Dispersion equipment, pressure gauge, safety valve, manhole for internal inspection, etc., should be provided.

6.3.3.1.7 Appurtenances

Decide the appurtenances after considering the following:

1. Install a sludge storage tank.
2. Install floatation sludge degassing tank.
3. Install thickened sludge storage tank.
4. Install sludge pump.
5. Install return flow tank (in case of return flow pressurization system).
6. If necessary, cover it and install ventilation and deodorization equipment.
7. If necessary, install chemical dosing equipment.

6.3.3.2 Dispersed-air Floatation Thickening

In this process, air bubbles generated by adding a foaming agent are attached to solids in the sludge, mixing equipment by adding a polymer coagulant and sludge is floated. The main equipment consists of floatation equipment, foaming equipment, mixing equipment, water level adjusting equipment and auxiliary equipment such as sludge pump and floatation sludge de-aeration tank.

Foaming agent and air mixed in water are agitated mechanically in foaming equipment and fine bubbles are generated under atmospheric pressure.

These bubbles are made to attach to the solids to which polymer coagulant is added and solids of bubbles and floc with strong bonding strength are formed.

The solids made of floc and bubbles are transferred to the floatation equipment and are floated, separated and removed, and the fine bubbles in sludge are mechanically agitated and removed. The centrate is drained out and it overflows from the water level adjusting equipment.

6.3.3.2.1 Capacity

The floatation tank capacity is determined considering the following:

1. The solids load is 25 kg dry solids/ (m²h) approximately, and the standard solids recovery rate is 95% and above.
2. Consider the effective water depth as approximately 4 m.

6.3.3.2.2 Shape and Number

The shape and number of floatation tanks are decided considering the following:

1. The standard shape of the tank is circular.
2. In principle, the number of tanks should be two or more tanks.

6.3.3.2.3 Structure

The structure of floatation tank is determined considering the following:

1. The standard material is durable and corrosion resistant steel.
2. To adjust the water surface, install weir and other equipments.

6.3.3.2.4 Sludge Remover and Sludge Scraper

A sludge remover that removes the froth and a sludge collector that scrapes and collects the settled sludge are installed in the floatation tank.

6.3.3.2.5 Control of Foaming

Sometimes sludge digesters are found to be foaming inside the digester. Technically this does not interfere with the treatment process and as long as it does not escape from the digesters into the atmosphere, this can be ignored. It tends to get controlled by itself. If the problem persists and foam is found in the sludge gas, commercially available anti-foaming chemicals can be briefly used as per the guidelines of respective manufacturers with proven track record in such applications.

6.3.4 Belt Type Thickening

When coagulant is loaded, the belt type thickener performs gravity filtering and thickening on a travelling belt, which may be a stainless steel belt or a plastic belt. While being transported to the discharge side, the sludge is filtered by gravity and thickened; it is separated by a scraper at the concentrated sludge discharge unit. The belt is subsequently washed with filtrate. Chemical conditioning equipment is used to mix sludge and polymer coagulant. In addition to the stand alone equipment, line mixing type equipment are also available.

6.3.4.1 Capacity

The capacity of belt filter press thickener is decided after considering the following:

1. The sludge volume is approximately 10 m³/hour to 100m³/hour.
2. The standard thickening performance is as given below.
 - i) Thickened concentration: 4-5% approx
 - ii) Chemical addition rate: 0.3% approximately (percent solid)
 - iii) SS recovery rate: 95% or greater

6.3.4.2 Shape and Number

The shape and number are decided after considering the following:

1. The standard shape is rectangular with the longer side being horizontal
2. In principle, the number should be two or more units

6.3.4.3 Chemical Dosing Equipment

Decide the chemical dosing equipment after considering the following:

1. Install coagulant dissolution tank
2. Install coagulant feeder
3. Install coagulant dosing pump

6.3.4.4 Appurtenances

Decide the appurtenances after considering the following:

1. Install sludge feed tank
2. Install thickened sludge storage tank
3. Install sludge pump
4. If necessary, cover it and install ventilation and deodorization equipment

6.3.5 Comparison of Different Types of Sludge Thickening

A comparison of different sludge thickening processes is presented in Table 6-7 overleaf.

6.4 ANAEROBIC SLUDGE DIGESTION

6.4.1 General

This is the biological degradation of organic matter in the absence of oxygen. In this process, much of the organic matter is converted to methane, carbon-dioxide and water and therefore, it is a net energy producer. Since, little carbon and energy alone is available to sustain further biological activity, the remaining solids are rendered stable.

6.4.1.1 Microbiology of the Process

Anaerobic digestion involves several successive biochemical reactions earned by a mixed culture of microorganisms. There are three degradation stages namely, hydrolysis, acid formation and methane formation. The reactions involved in anaerobic digestion are shown in Figure 6.4 overleaf.

In the first stage of digestion, complex organic matter like proteins, cellulose, lipids are converted by extra cellular enzymes into simple soluble organic matter. In the second stage, soluble organic matter is converted by acetogenic bacteria into acetic acid, hydrogen, carbon dioxide and other low molecular weight organic acids. In the third stage, two groups of strictly anaerobic methanogenic bacteria, are active. While one group converts acetate into methane and bicarbonate, the other group converts hydrogen and carbon-dioxide into methane. For satisfactory performance of an anaerobic digester, the second and third stages of degradation should be in dynamic equilibrium, that is, the volatile organic acids should be converted into methane at the same rate as they are produced.

Table 6.7 Comparative Evaluation of Different Sludge Thickening Processes

Evaluation Criteria	Gravity	Dissolved Air Flotation	Centrifugation	Gravity Belt	Rotating Drum
Space requirement	High	Medium	Low	Medium	Medium
Operation and maintenance	Simple	Medium	High	Medium	Medium
Typical Application	Primary and Combined	Waste activated sludge	Waste activated sludge	Waste activated sludge	Waste activated sludge
Conditioning Chemicals	None	High	High	Medium	Medium
Power requirement	Low	High	High	Medium	Medium
Capital Cost	Low	High	High	Medium	Medium
Operation Cost	Low	High	High	Medium	Medium
Thickened Sludge solids concentration	Medium	Low	High	Medium to high	Medium to high
Building corrosion if enclosed	High	Medium	None	Medium	Medium
Odour problem	Serious	Moderate	Low	Moderate	Moderate

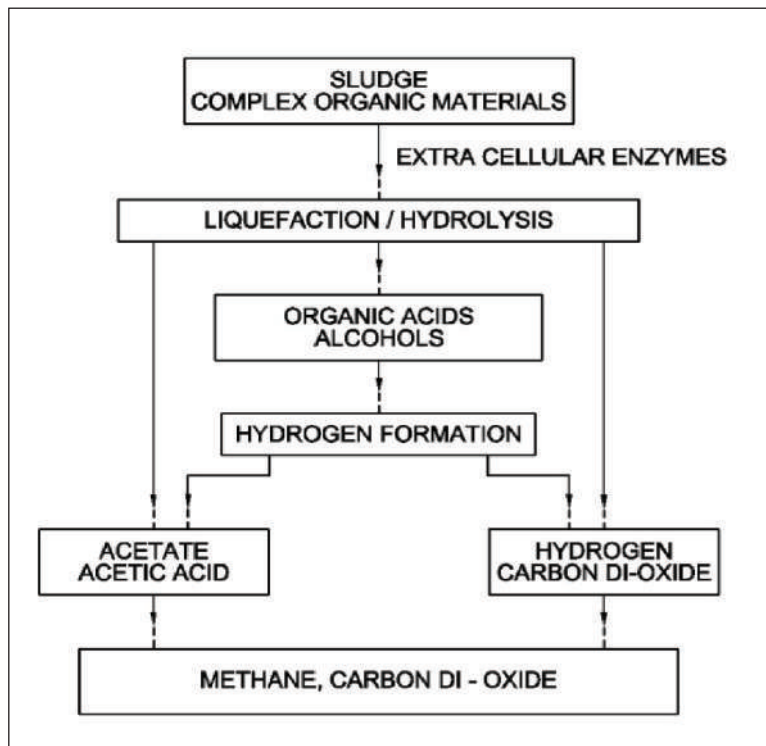


Figure 6.4 Anaerobic digestion mechanisms

However, methanogenic microorganisms are inherently slow growing compared with the volatile acid formers and they are adversely affected by fluctuations in pH, concentration of substrates and temperature. Hence, the anaerobic process is essentially controlled by the methanogenic microorganisms.

6.4.2 Digestion Types

Two different types in anaerobic sludge digestion processes are namely, low rate and high rate and are used in practice. The basic features are in Figure 6.5

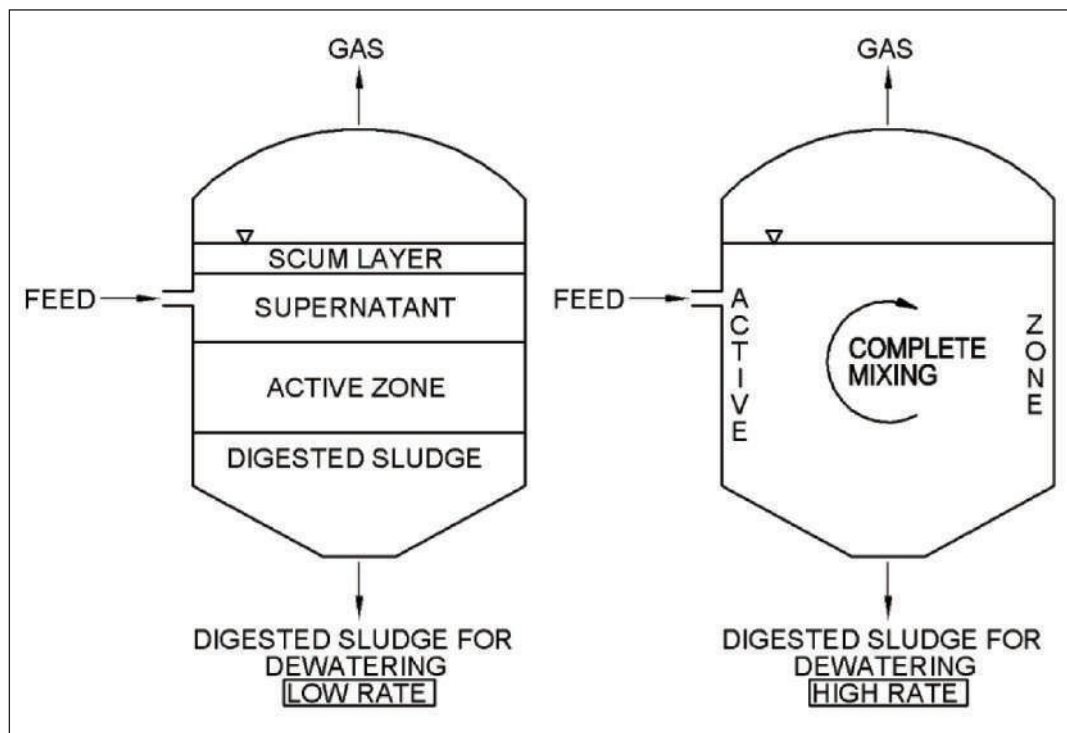


Figure 6.5 Sludge digestion system

6.4.2.1 Low Rate Digestion

Raw sludge is fed into the digester intermittently. Bubbles of sewage gas are generated and their rise to the surface provides some mixing. In the case of few old digesters, screw pumps have been installed to provide additional intermittent mixing of the contents, say once in 8 hours for about an hour. As a result, the digester contents are allowed to stratify, thereby, forming four distinct layers: a floating layer of scum, layer of supernatant, layer of actively digesting sludge and a bottom layer of digested sludge; essentially the decomposition is restricted to the middle and bottom layers. Stabilized sludge that accumulates and thickens at the bottom of the tank is periodically drawn off from the centre of the floor. Supernatant is removed from the side of the digester and returned to the treatment plant.

6.4.2.2 High Rate Digestion

The essential elements of high rate digestion are complete mixing and more or less uniform feeding of raw sludge.

Pre-thickening of raw sludge and heating of the digester contents are optional features of a high rate digestion system. All these four features provide the best environmental conditions for the biological process and the net results are reduced digester volume requirement and increased process stability.

Complete mixing of sludge in high rate digesters creates a homogeneous environment throughout the digester. It also quickly brings the raw sludge into contact with microorganisms and evenly distributes toxic substances, if any, present in the raw sludge.

Furthermore, when stratification is prevented because of mixing, the entire digester is available for active decomposition, thereby increasing the effective solids retention time.

Pre-thickening of raw sludge before digestion results in the following benefits:

1. Large reduction in digester volume requirements
2. The thickener supernatant is of far better quality than digester supernatant; thereby, it has less adverse impact when returned to the STP
3. Less heating energy requirements
4. Less mixing energy requirements

There is however, a point beyond which further thickening of raw sludge has the following effects on digestion:

- a) Solid concentration higher than 6% in the digester affects the viscosity, which in turn affects mixing, hence deserves special consideration.
- b) In case of highly thickened raw sludge, the concentration of salts and heavy metals present in the raw sludge and end products of digestion, such as volatile acids and ammonium salts, may exceed the toxic levels.

6.4.2.3 Sludge Temperature

Sludge temperature is one of the important environmental factors. Where the digester sludge temperatures are low, digester heating is beneficial because of the rate of microbial growth and therefore, the rate of digestion increases with temperature.

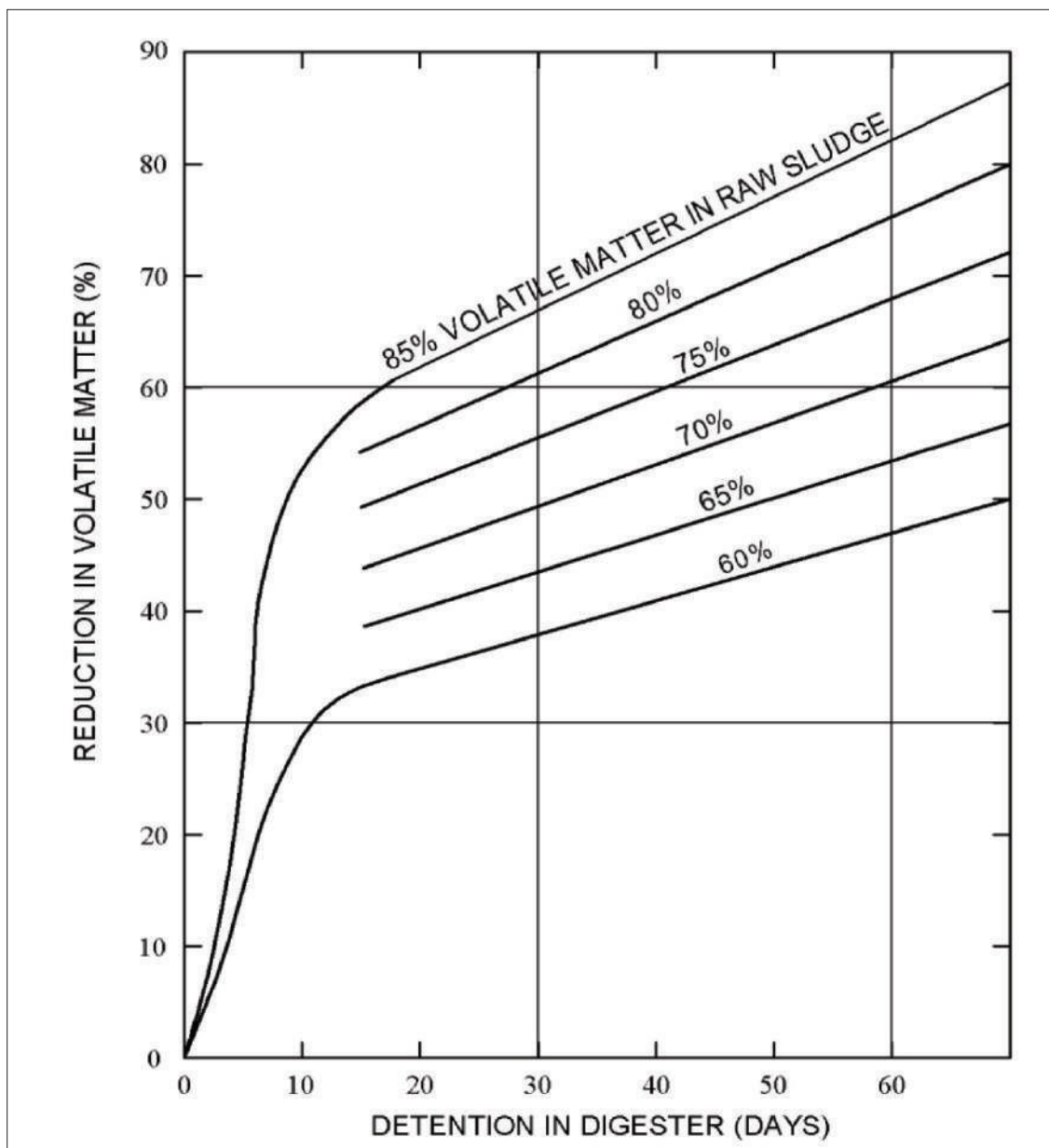
Depending upon the temperature, different kinds of microorganisms are active in the digester. For an operating temperature of 20° to 40°C, the range is known as mesophilic and for 40° to 60°C, the range is known as thermophilic.

The ambient temperature in our country is generally favourable for operation under mesophilic condition throughout the year. However, in special conditions such as hilly regions, where extremely low temperatures are likely to be encountered, it may be necessary to heat the digesters during specific periods of the year.

6.4.3 Digester Tank Volume

The determination of digester tank volume is a critical step in the design of anaerobic system. The digester volume must be sufficient to prevent the process from failing under all accepted conditions. Process failure is defined as accumulation of volatile acids that results in decrease in pH, when volatile acids/alkalinity ratio becomes greater than 0.5 and methane production stops. Once the digester turns sour, it usually takes several days to return to normal operation after the corrective actions are taken.

The digester capacity must also be large enough to ensure that raw sludge is adequately stabilized as discussed below in the section on solids retention time. The relationship between percentage volatile matter in the raw sludge, its reduction and detention time is shown in Figure 6.6.



Source: CPHEEO, 1993

Figure 6.6 Reduction of volatile matter as related to digester detention time

6.4.4 Sludge Loading Rate

6.4.4.1 Loading Criteria

Traditionally, volume requirements for anaerobic digestion have been determined from empirical loading criteria. Volatile solids loading rate (kg VSS/day/m³) criteria have been commonly used to size anaerobic digesters. Table 6.8 lists the typical loading rates used for design purpose. However, it is now recognized that process performance is better correlated to solids retention time (SRT), as shown in the table and is discussed subsequently.

Table 6.8 Typical design criteria for sizing mesophilic anaerobic sludge digesters

Parameters	Low Rate Digestion	High Rate Digestion
Volatile Solids Loading Rate, kgVSS/day/m ³	0.6 - 1.6	1.6 - 6.4
Solids Retention Time, days	(*)	10 - 20
Hydraulic Retention Time, days	30 - 40	10 - 20

Note: (*) Computation of actual SRT is difficult as it depends on the capacity utilization.

6.4.4.2 Solids Retention Time and Temperature

The most important consideration in sizing anaerobic digester is that the microorganisms must be given sufficient time to reproduce so that they can (a) replace the cells lost with the withdrawn sludge and (b) adjust the microbial mass to the organic loading and its fluctuation.

The key design parameter for anaerobic biological treatment is the biological solids retention time (SRT), which is the average time a unit of microbial mass is retained in the anaerobic digester without recycling. The SRT is equivalent to the hydraulic retention time, that is, volume of digester/volume of sludge withdrawn per day.

Experiments have proved that percentage of destruction of volatile solids and formation of methane decreases as the SRT is reduced. The SRT can be lowered to a critical point (SRT_c) beyond which the process will fail completely.

The temperature has an important effect on bacterial growth rates and accordingly changes the relationship between SRT and digester performance. The effect of temperature on volatile solids destruction is presented in Figure 6.7 overleaf.

The inset in Figure 6.7 shows that at SRT values greater than 30 days, fluctuations in temperature do not affect the digester stability, that is, no significant change in percentage volatile solids reduction. The size of anaerobic digester should be adequate enough to ensure that the solids retention time in the system is always well above the SRT_c. Typical solids retention time design criteria followed for high rate digestion design are given in Table 6.9 overleaf.

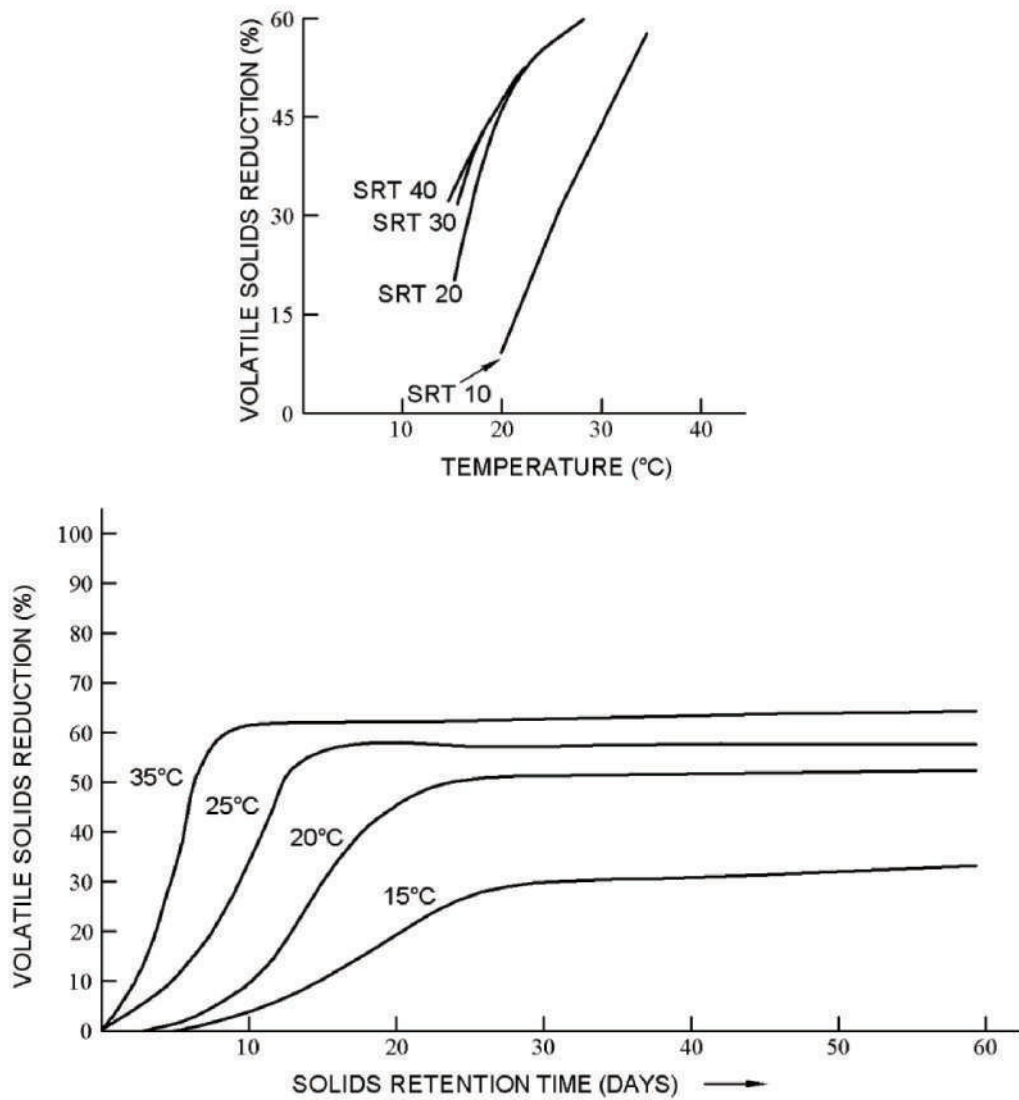


Figure 6.7 Effect of solids retention time and temperature on volatile solids reduction in a laboratory scale completely mixed aerobic digester

Table 6.9 Solids retention time at different temperatures (high rate digestion)

Operating Temperature, °C	Solids Retention Time, days		
	SRTc	Suggested for Design (SRTd)	Ratio
18	11	28	28/11 = 2.54
24	8	20	20/8 = 2.5
30	6	14	14/6 = 2.3
35	4	10	10/4 = 2.5
40	4	10	10/4 = 2.5

The SRT design criteria must be met under all anticipated conditions including:

1. Maximum grit and scum accumulations: Considerable amount of grit and scum may accumulate before a digester is cleaned. This reduces the active volume of the tank. Hence, about 0.6m to 1.0m additional depth for grit and scum accumulation must be provided.
2. Free Board: About 0.6 to 0.8m free board (from rim of the digester wall to the highest liquid level) must be allowed for differences in the rate of feeding and withdrawing and to provide reasonable operational flexibility.

6.4.4.3 Storage for Digested Sludge

Storage capacity for digested sludge is required in places where digested sludge is applied to drying beds for dewatering, and use of sludge drying beds is interrupted during monsoon periods.

This additional capacity requirement can be met either by increasing the digester capacity or by providing a separate digested sludge holding tank. Normally, an additional 10-15 days digested sludge storage capacity can be sufficient. However, if local meteorological data is available, such data should be used to determine the capacity of storage.

6.4.5 Sizing

6.4.5.1 Sizing of Low Rate Digesters

Lack of proper mixing in the conventional digesters leads to stratification, and gives rise to distinct layers of scum, supernatant, actively digesting sludge and digested sludge. The supernatant is withdrawn periodically and returned to the influent of the treatment plant, while the sludge is added at mid depth and withdrawn from the bottom. Since the supernatant is removed during digestion resulting in a decrease in digested sludge volume, the capacity of the digester is given by the expression:

$$V = [V_f - 2/3(V_f - V_d)]T_1 \quad (6.1)$$

Where,

V : Volume of digester, m^3

V_f : Volume of fresh sludge m^3 added per day

V_d : Volume of digested sludge m^3 withdrawn per day

T_1 : HRT, days

Sometimes sludge drying beds alone are used and left in the open under the sky. In such cases, the rainfall in monsoon times results in many environmental problems. Hence, sludge storage facilities for the monsoon season are to be provided. The volume is given by the expression:

$$\text{Additional monsoon storage volume} = V_d T_2 \quad (6.2)$$

Where, T_2 is the storage in days, during monsoon

The digester can be a single unit or two units – the primary and the secondary, the former being provided with the needed time for digestion and the latter to meet the requirements of monsoon storage. As discussed in the above Subsection 6.4.3, further additional capacity to compensate for grit accumulation and free board should be provided.

6.4.5.2 Sizing of High Rate Digester

Due to good mixing, there is no stratification hence, no loss of capacity due to scum or supernatant layers. By adopting more or less continuous addition of raw sludge and resorting to pre-thickening of the raw sludge to a solid content of about 6%, the digester volume can be designed for 10-15 days retention time.

When the digested sludge is to be dewatered on sludge drying bed, a second stage digester is normally provided where separation of supernatant and reduction in volume of sludge due to gravity thickening take place and digestion is completed. Additional storage capacity needed for the monsoon period can also be provided in the second stand digester. Capacities for high rate digestion may be determined by:

$$V' = V_f T_h \quad (6.3)$$

$$V'' = [V_f - 2/3(V_f - V_d)]T - V_d T_2 \quad (6.4)$$

Where,

V' : Volume of first stage digester, m^3

V'' : Volume of second stage digester, m^3

V_f : Volume of fresh sludge m^3 added per day

V_d : Volume of digested sludge m^3 withdrawn per day

T_h : Detention time in the high rate digester, days

T : Detention time in the second stage digester which is of the order of 10 days and

T_2 : Storage in days, during monsoon

As discussed in the above subsection 6.4.3, while computing the digester volume, additional volume to compensate for grit accumulation and free board should be provided.

The mass balance calculation in the 1993 edition in word has since been converted to M S Excel format and is presented as Appendix A.6-1. An example of digester sizing is presented in Appendix A.6.4.

6.4.6 Structure

6.4.6.1 Number of Units

Conventional digesters are designed as single units for plants treating up to 4 MLD. For larger plants, units are provided in multiples of two, the individual capacity not exceeding 3 MLD. High rate digesters are designed comprising primary and secondary digestion tanks, each unit generally capable of handling sludge from treatment plants up to 20 MLD.

6.4.6.2 Digester Shape and Size

The most common digester shape is a low, vertical cylinder with diameter ranging from 6 to 38 m and with height ranging from 6 to 12 m. Digester mixing is effective when the ratio of digester diameter to sludge depth is between 1.5 and 4. Computational Fluid Dynamics (CFD) to decide on structural design is used. Figure 6.8 shows typical Low height cylindrical, Egg shaped and tall form cylindrical digesters.




		
<p>Low Height Cylindrical Source: Perungudi STP- Chennai Metropolitan Water Supply & Sewerage Board</p>	<p>Egg Shaped Location: Kanazawa STP, Yokohama City, Japan, Source: Kajima Corporation</p>	<p>Tall form Cylindrical Source: Article on Biomethanation by A K Dhussa and V K Jain, Newsletter, National Bioenergy Board, MNRE, March 2002.</p>

Figure 6.8 Typical low height cylindrical, egg shaped and tall form cylindrical digesters

6.4.6.3 Free Board and Depth

The free board is dependent upon the type of cover and the maximum gas pressure. For fixed dome or conical roofs, free board between the liquid level and the rim of the digester wall should not be less than 0.6m. For flat covers, the free board between water level and the top of the tank wall should preferably be not below 0.6 m. For fixed slab roofs, a free board of 0.8m is recommended. Sludge depth in a digester has to be carefully worked out. Too deep a digester causes excessive foaming, which may result in choking of the gas pipes and building up high pressures in the digester. In case of conventional low rate digester, when gas production reaches, a figure of about $9 \text{ m}^3/\text{day}/\text{m}^2$ of top surface of sludge foaming becomes noticeable. Therefore, before the tank depth and surface area of a digester are worked out, maximum gas production rate should be determined. An average of about 0.9 m^3 of gas is produced per kg of volatile solids destroyed. The optimum diameter of depth of digester is calculated such that at the average rate of daily gas production, the value of 9 m^3 per m^2 of tank area is not exceeded.

6.4.6.4 Floor Slope

The floor slope should be in the range of 1 in 6 to 1 in 10 to facilitate easy withdrawal of sludge. The digester floor should be designed for uplift pressure due to the subsoil water or suitably protected by anchoring.

6.4.6.5 Roofing

Sludge digesters can have either fixed or floating roofs. Reinforced concrete domes, conical or flat slabs are used for fixed roof and steel domes are used for floating cover. Steel floating covers may either rest on the liquid or act as gas holders in the digesters themselves. If a floating cover is used for gas holder in a digestion tank, an effective vertical travel of 1.2 to 2m should be provided.

6.4.6.6 Digester Control Room

Normally a control room is provided near the digesters to house the piping and the process control equipment, which are principally the sludge heating units (if used), sludge transfer and recirculation pumps, sludge sampling sinks, thermometers, blowers for ventilation and electrical control equipment. Where heating of sludge digesters is practiced, the operation could be managed by locating conveniently the necessary valves for supernatant and sludge withdrawal in the digester wall itself. However, in sewage treatment plants having more than four digesters, it is advisable to have a separate operation control room to house the necessary control equipment for convenient operation.

6.4.7 Mixing System

A certain amount of natural mixing occurs in anaerobic digester caused by both the rise of sludge gas bubbles and the thermal convection currents created by the addition of fresh or heated sludge. This effect of natural mixing is significant, particularly in case of high rate digesters fed continuously. However, this natural mixing is not sufficient to ensure stable performance of the digestion process. Therefore, methods used for mixing include external pumped circulation, internal mechanical mixing and internal gas mixing.

External pumped circulation while relatively simple is limited in application because of large flow rates involved. However, this method can achieve substantial mixing, provided sufficient energy in the range of 5 to 8 watts/m³ is dissipated in the digester. More energy will be required if piping losses are significant. Pumped circulation allows external heat exchanges to be used for heating the digester contents and uniform blending of raw sludge with heated circulating sludge prior to the raw sludge entry to the digester.

Internal mechanical mixing by means of propellers, flat-bladed turbines, or draft tube mixers are also often used. Mechanical mixers can be installed through the cover or walls of the digester.

Substantial mixing can be effected with about 5 to 8 watts/m³ of digester content is dissipated in the digester.

Internal gas mixing types normally used for digesters are

1. The injection of a large sludge gas bubble at the bottom of a 30 cm diameter tube to create piston pumping action and periodic surface agitation
2. The injection of sludge gas sequentially through a series of lances suspended from the covers to as great a depth as possible, depending on cover movement

3. The free or unconfirmed release of gas from a ring of spargers mounted on the floor
4. The confined release of gas within a draft tube positioned inside the tank

The first method generally has a low power requirement and consequently, produces only a low level of mixing. As a result, the major benefit derived from its use is in scum control. Lance free gas lift and draft tube gas mixing, however, can be scaled to induce strong mixing of the digester contents.

The circulation patterns produced by these two mixing methods differ. In the free gas lift system, the gas bubble velocity at the bottom of the tank is zero, accelerating to a maximum as the bubble reaches the liquid surface. Since the pumping action of the gas is directly related to the velocity of the bubble, there is no pumping from the bottom of the tank with a free gas lift system.

In contrast, a draft tube acts as a gas lift pump which, by the law of continuity, causes the flow of sludge entering the bottom of the draft tube to be the same as that exiting at the top. Thus, the pumping rate is largely independent of height.

The significance of this difference is that draft tube mixers induce bottom currents to prevent or at least reduce accumulations of settling material. Another difference among internal gas mixing systems is that the gas injection devices in a free gas lift system are fixed on the bottom of the digester and thus, cannot be removed for cleaning without draining the tank.

To reduce clogging problems, provisions should be made for flushing the gas lines and diffusers with high pressure water.

With the lance and draft tube systems, the gas diffusers are inserted from the roof and, therefore, can lie withdrawn for cleaning without removing the contents of the tank.

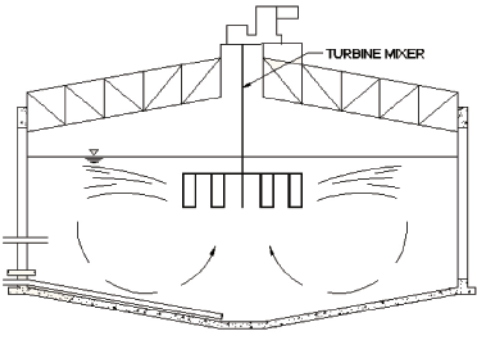
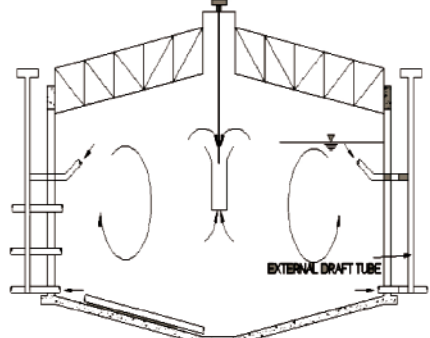
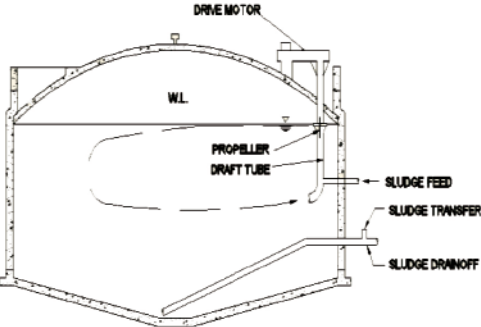
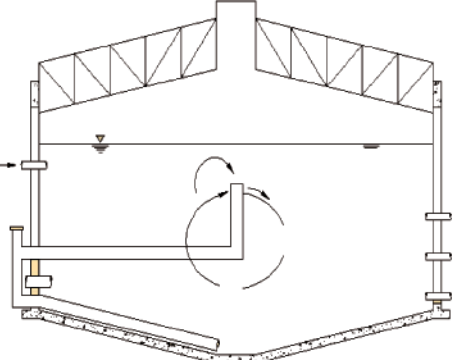
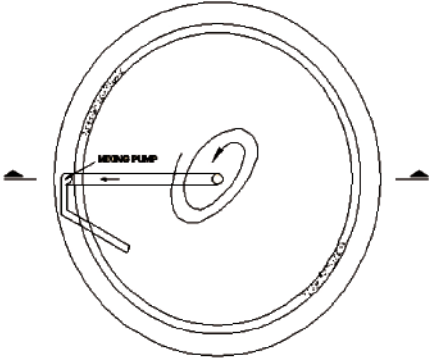
A drawback in these systems, is that the draft tube and gas lines inside the tank may foul with rags and debris in the digesting sludge. Some of these are compiled in Figure 6-9 and Figure 6-10.

There are many types of sludge mixing arrangements in tandem with the shape of digesters. However, as far as India is concerned, the cylindrical digesters with either mechanical agitator mixers or externally sludge recirculated pump sets are more common.

The cylindrical digester with the upper and lower compartments and gas induced central draft tube mixing system is in use in cattle dung, abattoir waste and vegetable market waste biomethanation plants with subsidy from the Ministry of New and Renewable Energy (MNRE).

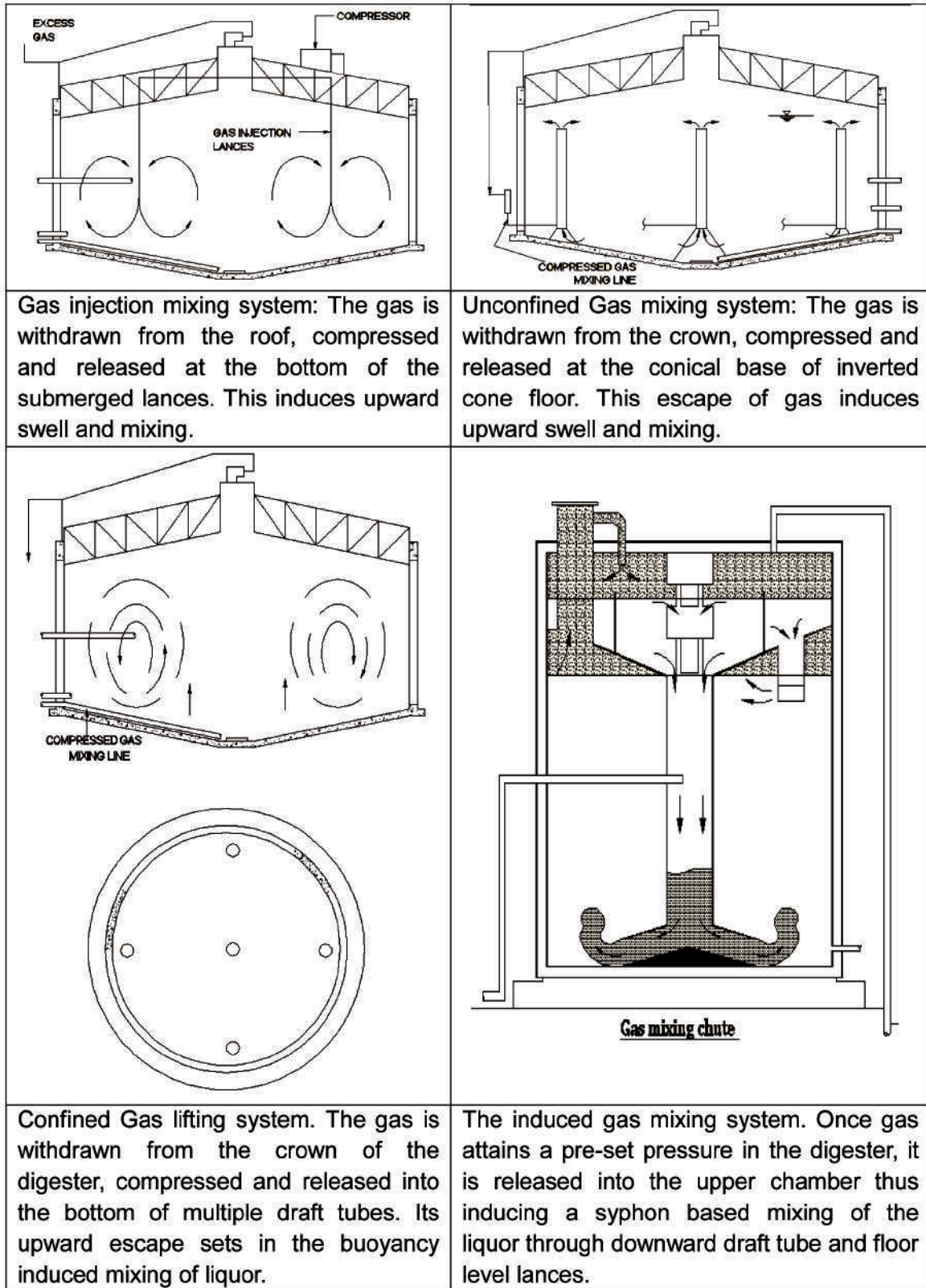
However, there is very limited information either in India or elsewhere on the effectiveness of their geometry Vs the efficiency of mixing system. Recently, this had engaged the attention and Computational Fluid Dynamics (CFD) modelling approach is being explored to optimize the degree of mixing for the energy put in.

The usefulness of this type of modelling can be seen from the documentation of a reported study as reproduced in Figure 6.11.

	
<p><u>Mechanical mixing system:</u> The entire digester contents are subjected to a central vortex based uplift and its all round throw of the liquor at the surface. This results in a hydraulic mixing in all the vertical planes.</p>	<p><u>Mechanical mixing system:</u> A combination of a central draft tube with downward turbine & external draft tubes relying on downward hydraulic energy dissipated in the draft tube.</p>
	<p><u>Mechanical mixing system:</u> A combination of multiple downward draft tubes along inner rim with spouted ends to suck in the feed sludge and pump towards the centre and in turn the upward circulation to draft tubes.</p>
	
<p><u>Pumped feed system:</u> The liquor is withdrawn by pumped suction from the tip of the digester conical floor and/or near the upper zone and is pumped back in multiple tangential pumped ends to sustain mixing.</p>	

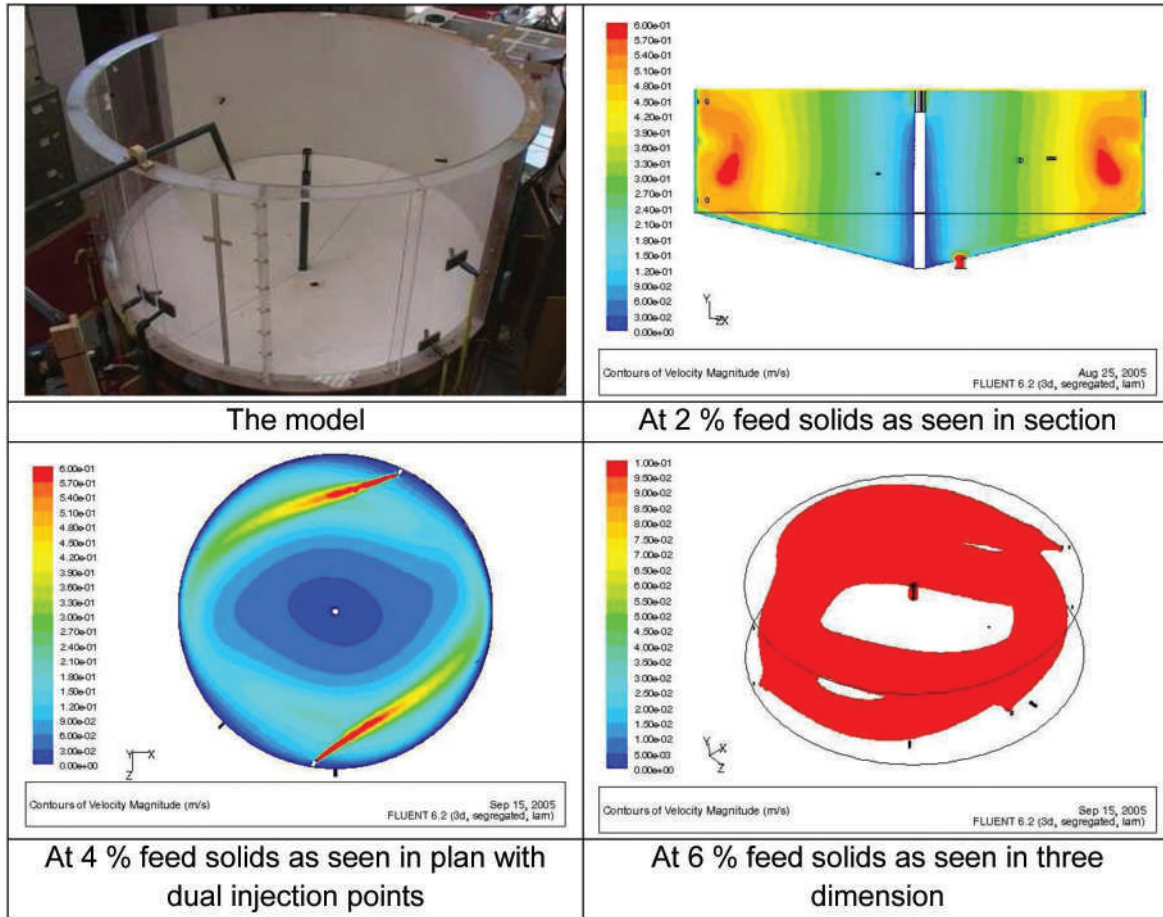
Source: WEF Manual of Practice 8

Figure 6.9 Some of the mechanical mixing systems in digesters



Sources: (1) WEF Manual of Practice-8,
 (2) Article on Biomethanation by AK Dhussa and VK Jain, Newsletter, National Bioenergy Board, MNRE, March 2002.

Figure 6.10 Some of the gas based mixing systems in digesters



Source: D Harrison et. al., 2006

Figure 6-11 CFD Modelling results of digester mixing efficiency

CFD is a mathematical modelling technique that solves fundamental flow equations for each cell in a mesh, 1.6 million in this instance, to form a construct of the equipment being investigated. The flow field within the equipment is simulated and flow patterns, velocities, residence time distributions, additive blend times, pressure drops and other relevant parameters can be determined. Many single and some multi-phase flows can be modelled. Knatz. et. al. (2010).

To assess this effect a CFD model of the digester is stated to have been constructed at the Orange County Sanitation District STP in USA using both physical and CFD models. The mixing system is stated to have been simulated at 2 percent, 4 percent and 6 percent dry solids concentration. At 2 percent dry solids concentration, the mixing was shown to be very effective with over 90 percent of the digester volume being actively mixed and the feed blend time being calculated as 1.7 hours. At 4 percent digested solids concentrations the active volume was calculated as 45 percent with a blend time of 8.5 hours and at 6 percent dry solids concentration the active volume was greatly reduced to less than 28 percent and blend time was in excess of a day.

It was inferred that doubling the dry solids concentration within the digester will be more than halve the active volume provided by the digester mixing system.

The CFD model is not just a tool to evaluate the effect of increasing viscosity on digester mixing performance. Once constructed and calibrated, the CFD model can also be used to test modifications to the digester mixing system to improve performance at elevated dry solids concentrations.

Accordingly, it is to be recognized that investigating the integrated approach to size, shape and mixing efficiency is to be given its due importance in firming up future digester systems.

6.4.8 Heating System

Heating and boiler systems are decided after considering the following:

1. Heating method

- i. Direct heating method (steam blow-in system). This consists of blowing high-temperature steam directly into the sludge in the tank. As long as agitation is satisfactory, the degradation of biotic action due to steam is small, both equipment and operation are simple, so this method is widely used. This requires boiler make-up water equivalent to the steam blow-in quantity.
- ii. Indirect heating system (system using heat exchanger) - The indirect heating system consists of a heat exchanger installed outside the tank. The sludge that circulates around the tank and heat exchanger are heated by the hot water circulating around the heat supply source and the heat exchanger. The heat exchanger may be of two types – double tube and spiral type.

The double tube heat exchanger consists of an inner tube in which the sludge flows and an outer tube around which hot water flows in the opposite direction.

The spiral type heat exchanger consists of heat transfer plate wound in spiral form within the cylindrical pipes in which sludge and hot water flow in opposite directions.

The indirect heating system has more equipment such as circulating pump and heat exchanger, compared to the steam blow-in system, but since digested sludge circulates, agitation of the sludge is facilitated.

2. Heat required for heating consists of the heat required for the loaded sludge, and the radiation heat loss to surrounding from the heating pipes and tank.
3. The boiler capacity is decided after considering the maximum heat of the sludge digestion tank, the operating hours and the number of boilers. The number of boilers should be two or more in principle.
4. The construction of the boiler should be based on relevant laws and standards, and should be such that boiler can be operated in a stable manner.
5. Steam pipes should be covered by insulating material; steam trap and vacuum breaker should be installed in the steam piping system. Liquid depth at blow-off and shape of blow-in part should be considered so as to prevent abnormal noise and vibration in the steam blow-in pipes.

6.4.9 Sludge Inlets and Draw-offs

Sludge inlets and draw-offs are decided after considering the following:

1. Thickened sludge inlet pipe should be installed at such a position that sludge is dispersed uniformly in the tank.
2. The sludge withdrawal pipe should be at least 150 mm in suction drawal and 200 mm in gravity drawal.
3. Consideration should be given to preventing clogging of sludge pipes.
4. Considerations should be given to power outages for sludge draw-off valve.

6.4.10 Supernatant Withdrawal and Treatment

For withdrawal and treatment of supernatant liquor, the following should be considered.

6.4.10.1 Supernatant Liquor Draw-off Pipe

The supernatant liquor draw-off pipes should be laid such that supernatant liquor can be drawn off at varying water depths. In a secondary tank for two-stage digestion, supernatant liquor with small SS concentration occurs between the concentrated digested sludge at the bottom and the layer with a major concentration of floating solids near the water surface. The water depth at which satisfactory supernatant liquor is generated differs depending on the digestion level; therefore, draw-off pipes should be installed at 3 to 4 different locations from half the depth of the tank, and the best location from these should be selected.

The draw-off of supernatant liquor in the secondary tank should be performed from the overflow pipe. Piping to bypass the overflow pipe should be kept ready, considering operation by controlling the liquid level during transfer to secondary tank, draw-off of supernatant liquor and withdrawal of digested sludge. The pipe diameter should be minimum 150 mm.

6.4.10.2 Supernatant Liquor Return Piping

After directly treating the supernatant liquor, piping should be laid such that it can be returned to the grit chamber or primary settling tank and so on.

The quantity of supernatant liquor is small compared with the influent sewage, but consideration should be given from the beginning so that high load does not act temporarily on sewage treatment. Although it is common to return the supernatant liquor to the grit chamber and primary settling tank and treated, it may be returned and treated independently if necessary. If discharge piping within the premises is used as return piping, it becomes difficult to understand the quality of influent sewage because of its mixing in the grit chamber.

In case of combined sewerage system, issues of effluent delivery during rainfall exist; therefore, it is preferable to use dedicated piping that is separate from the discharge piping within the premises.

Treatment of supernatant liquor containing highly concentrated COD, phosphorous, nitrogen, etc., should be studied in conjunction with the return flow from other sludge treatment facilities. Measures for return flow with the aim of removing phosphorous include the MAP method developed recently (crystallization of MAP granules). Although the generated MAP granules include potassium, it also includes components and has properties that are suitable for fertilizer, such as nitrogen and phosphorous.

6.4.11 Guidelines for Sludge Piping Architecture

The following guidelines taken from “Design Guidelines for Sewage Works, 2008, Ministry of the Environment, Ontario, PIBS 6879” are considered useful.

1. Digested sludge withdrawal piping should have a minimum diameter of 200 mm (NPS-8) for gravity and 150 mm (NPS-6) for pump suction and discharge lines.
2. Clearance between the end of the withdrawal line and the hopper walls should be sufficient to prevent bridging of the sludge.
3. Adequate provisions should be made for rodding or back-flushing pipe lengths.
4. Where withdrawal is by gravity, the available head on the discharge pipe should be at least 120 cm and more. The same is good for pumped deliveries also.
5. Gravity piping should be laid on uniform grade and alignment.
6. Slopes on gravity discharge piping should be at least 3 percent for primary sludge and at least 2 percent for aerobically digested sludge
7. Where gravity sludge transfer is proposed, provision should be made for a pumped transfer on a regular basis to remove deposits and clean out the lines.
8. Valves should be provided to allow for both gravity and pumped transfer. Cleanouts should be provided for all gravity sludge piping.
9. The section of piping between isolation valves should have drain and vent valves or other means to relieve built-up pressure, due to gas formation, prior to dismantling the piping for cleaning or repairs.
10. Special consideration should be given to the corrosion resistance and permanence of supporting systems for piping located inside the digestion tank.
11. Adequate provisions should be made for rodding or back-flushing individual pipe runs. Piping should be provided to remove sludge for further processing.
12. Air-lift pumps are not recommended for the removal of primary sludge.
13. The tank bottom should slope to drain toward the withdrawal pipe. For tanks equipped with a suction mechanism for sludge withdrawal, a bottom slope not less than 1 to 12 is required.

14. Where the sludge is to be removed by gravity a 1 to 4 slope is recommended.
15. Maximum flexibility should be provided in terms of sludge transfer (a) from primary and secondary units to the digesters, (b) between primary and secondary digesters and (c) from digesters to subsequent treated sludge or biosolids handling operations.
16. An unvalved vented overflow should be provided to prevent damage to the digestion tank and cover in case of accidental overfilling.
17. This emergency overflow should be piped to an suitable point and at an suitable rate to the STP liquid train or side stream treatment facilities to minimize the impact on process units.
18. Many clean outs and plugged tees or crosses should be provided. Elbows and sharp turns should be avoided.
19. If the sludge flow is small, large capacity pumping with a timer should be used to flush the line during the pumping cycle. The pump should have sufficient head to move the settled solids.
20. Provision for high-pressure water jet, pipe rodding and cleaning devices is needed.
21. Long sludge lines should have bypass lines for cleaning and maintenance.

6.4.12 Gas Collection and Storage

6.4.12.1 Gas Collection

Sludge gas is normally composed of about 60% to 70% methane and 25% to 35% carbon dioxide by volume, with smaller quantities of other gases like hydrogen sulphide, hydrogen, nitrogen and oxygen. The combustible constituent in the gas is primarily the methane.

Depending upon the sulphate content of the sewage and the sludge, the concentration of hydrogen sulphide in the gas varies. Hydrogen sulphide in addition to its corrosive properties imposes a limit on the usability or causes nuisance during the burning of the gas.

The gas can be used as heat energy in a gas engine to generate electricity for in plant consumption or piped to nearby institutions like the case of the Dadar STP at Mumbai or merely flared.

Minimum or maximum rates of gas production will however, depend upon the mode of feeding of raw sludge into the digester, when batch feeding is practiced, the minimum and maximum gas production rates may vary from 45% to more than 200%.

In the continuous feeding system, the difference between the maximum and the minimum is considerably reduced. Intermittent mixing of digester contents is also responsible for wide fluctuations in gas production rates.

It is, therefore, desirable to feed the high rate digesters with raw sludge and run the mixing device as continuously as possible to obtain not only a uniform rate of digestion, but also uniform production of gas.

Sludge gas should be collected under positive pressure to prevent its mixing with air and causing explosion. The explosive range of sludge gas is between 5% and 15% by volume of gas with air. The gas may be collected directly from under a floating cover on the digester or from the fixed cover by maintaining a constant water level. Where primary and secondary units are provided to operate in series with the primary having a fixed cover and the secondary with a gas holding or floating cover, the gas piping from each digester should be interconnected. A separate gas holder may be provided to collect the gas from the primary unit where the secondary units are kept open.

A fixed integrally built gas dome above the digester roof is advantageous for gas take off. The velocity in sludge gas piping should not exceed 3.5 m/s to prevent carryover of the condensate from the condensation traps and avoid high pressure loss and damage to meters or flame traps and other appurtenances of the system.

An integrating meter made of corrosion resistant material should be used to measure gas production from the digesters. Removal of condensate from the meter is also desirable. Pressure release valves are provided for controlling the gas in the digester by releasing gas pressure exceeding 200 to 300 mm of water and also preventing partial vacuum and possible cover collapse during rapid withdrawal of sludge or gas.

A mandatory distance of at least 30 m should be kept between a waste gas burner and a digestion tank or gas holder to avoid the possibility of igniting the gas mixture. Waste gas burners should be located in the open for easy observation. A pilot device should also be provided with the waste gas burners. Condensate traps, pressure release valves and flame traps should also be provided ahead of waste gas burners. Manometers indicating the gas pressure in cm of water may be used on the main gas line from the digester or ahead of the gas utilization device. A common open end U tube manometer should not be used for such purposes as it may be hazardous.

6.4.12.2 Storage (Gas Holder)

The primary purpose of a gas holder is to adjust the difference in the rate of gas production and consumption as well as to maintain uniform pressure at the burner. When gas holders are also used for storage of gas for utilization, a storage capacity of at least 25% of the total daily gas production should be provided. The gas holders may be of the following types:

1. A bell shaped cylindrical tank submerged in water installed either on the top of a digester or as a separate unit. The structure holding the water may be made of RCC. As the gas enters or leaves, the holder rises or falls.
2. A pontoon cover type that floats on the liquid content of the digester consisting of steel ceiling, skirt plates, a gas dome and steel trusses
3. Dry type gas holder consisting of a cylindrical steel tank in which a disc-shaped piston makes contact at its periphery with the inside of the tank. The gas enters the holder from beneath the piston which floats on the gas. Leakage of gas is prevented by either tar or a felt seal around the edge of the piston. A suitable roof should be provided if this type of dry gas holder is installed.

4. A high pressure holder either cylindrical or spherical in shape and made of either welded or netted steel, for storing the gas under high pressure. This type of gas holder is seldom used for sewage treatment plants unless the gas has to be utilized for special purposes.
5. A relatively trouble-free gas holder is the flexible inflatable fabric top, as it does not react with the H₂S in the biogas and is integral to the digester. These types of covers are often used with plug-flow and complete-mix digesters. Flexible membrane materials commonly used for these gas holders include high-density polyethylene (HDPE), low-density polyethylene (LDPE), linear low density polyethylene (LLDPE), and chlorosulfonated polyethylene covered polyester.

The appurtenances for gas holders include ladders, condensate drains, pressure gauges and safety valves. Typical drawings and photographs are as in Figure 6.12 and Figure 6.13.

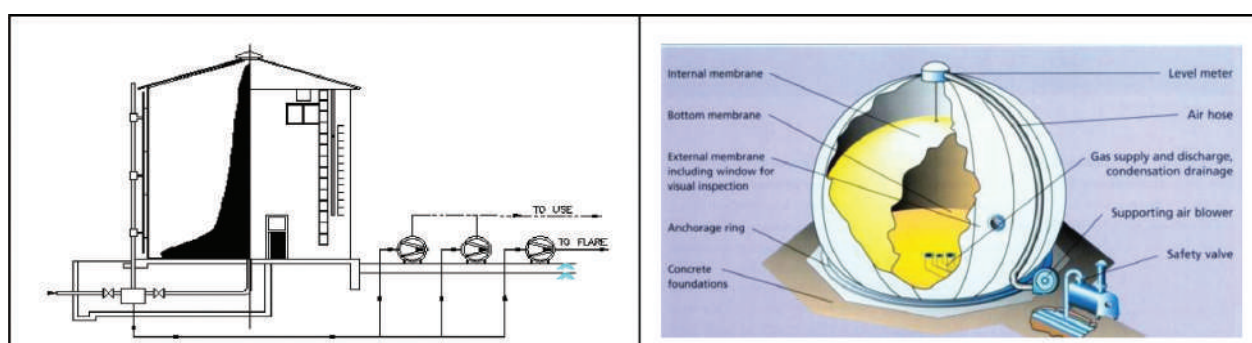


Figure 6.12 Illustrative flexible gas holder configurations.

At left in Figure 6.12 is a top held holder. It expands in the shape of a cone and is housed inside a structure. The left half shows the inside and the right half is the outer with doorway, vents and ladder. At right in Figure 6.12 is a bottom held holder. It expands as a sphere and is protected by another outer sphere. The filling and withdrawal of gas is at the bottom. Lightning arresters are mandatory. (There are many other configurations and the ones shown here are only illustrative).



Figure 6.13 A view of the gas holders.

6.4.13 Piping

Cast iron is commonly used for pipelines carrying sludge including fittings and joints. Pipes should be well supported and be capable of being drained. Vents should be provided at high points in order that the gas generated by the digesting sludge does not accumulate in these pipelines.

Adequate number of flanges and flexible couplings should be provided on exposed sludge lines to facilitate dismantling and insertion of cleaning equipment whenever necessary. In long pipe runs, tees with flanges equipped with 40 to 60 mm hose connectors should be provided for easy cleaning and flushing of the pipe. Flushing is an important requirement and arrangements should be provided for flushing with water or treated sewage.

A minimum diameter of 200 mm should be used for the sludge pipelines for both gravity withdrawal and suction to pumps. Velocities of 1.5 to 2.4 m/s should preferably be maintained to prevent solids deposition and accumulation of grease.

Primary and digested sludge have different hydraulic characteristics from those of water, though the secondary sludge is almost similar to water in its characteristics. The head loss in sludge pipes increase with the increase in percentage of solids and as such 'C' values of 40 to 50 in the Hazen William formula should be used for designing the pipelines.

For gas lines CI, GI or HDPE are commonly used. Galvanized steel may also be used for exposed gas piping. Flanged joints may be provided for exposed gas piping of sizes 100 mm and above in diameter while screw or welded type joints are recommended for pipe less than 100 mm. Mechanical joints should be used for underground piping. It is necessary that all gas piping be located at a level that will allow proper draining of the condensate. It is desirable to maintain a gas pipe slope of 1 in 50 with a minimum of slope of 1 in 100 for adequate drainage. Gas pipes should preferably be painted with bituminous coating. For a diameter of 100 mm and above, CI with flanged joints or flexible mechanical joints are used.

Adequate pipe supports should be provided to prevent breakage. It is desirable to provide a flanged pipe bypass before a gas meter, a firm foundation should also be laid below the pipe and caution must be exercised during back filling to prevent any disturbance of the alignment and grade. In highly acidic or alkaline soils, the pipe must be wrapped with either asbestos or some other protective material. Coal tar enamel may also be used in some cases. Cathodic protection is not generally needed on gas lines.

Adequate number of drip traps must be provided in gas pipelines, especially at the downward bends. Suitable number of tees should also be provided with removable screwed plugs or flanges for cleaning purposes. A drip trap of 1 litre capacity would be satisfactory. Trap outlets should run to floor drains wherever convenient. It is preferable to use positive type traps, which prevent gas from escaping while emptying the condensate.

6.4.14 Appurtenances

6.4.14.1 Sampling Sinks and Valves

A sink should be provided for each digester unit for drawing the supernatant liquor and sludge from various levels in the digester. Sinks should either be of white enamelled cast iron or of stainless steel. They should be made at least 30 cm deep. The supply of adequate water for flushing the sinks should also be provided. The sludge sampling pipes of SS should be short and 40 to 50 mm in diameter and arranged to draw samples from at least three levels at 0.6 m intervals. Sink valves should be brass plug type or CI flanged type.

6.4.14.2 Liquid Level Indicator

The digester may be designed for a fixed liquid level. Alternatively, a liquid level indicator with gauge board or any other device may be used for each digester.

6.4.15 Corrosion Prevention

The temperature and humidity of digester gas are high, and the gas contains hydrogen sulphide, hence, it is strongly corrosive. Therefore, preventive measures are necessary for parts in contact with sludge including digester gas. The following should be considered in relation to preventing corrosion:

6.4.15.1 Material of Equipment and Piping Parts in Contact with Sludge and Digester Gas before Desulphurization

Stainless steel and ductile cast iron coated with epoxy powder coating, etc., should be used as the material of equipment and piping parts in contact with sludge and digester gas before desulphurization. If the use of carbon steel is unavoidable, adequate measures such as preventing corrosion by providing a lining, etc., should be considered. Corrosion resistant synthetic rubber should be used in gaskets of flanges. Natural rubber should not be used.

6.4.15.2 Coating of Parts of Piping and Equipment in Contact with Digester Gas and Sludge

Epoxy resin-based paints and coating should be used considering resistance to heat and chemical action for coating on parts in contact with digester gas and sludge. To prevent rise in temperature of gas holder due to sunlight, the coating on the outside should preferably be in a colour that absorbs very little light from the sun.

6.4.15.3 Stripping of Hydrogen Sulphide in Digester Gas

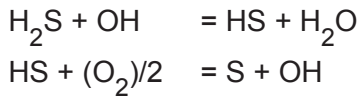
Typically, the digester gas contains Methane (CH_4), Hydrogen Sulphide (H_2S) and Carbon Di-oxide (CO_2). Standard requirements for dealing with digester gas are either electricity generation by using appropriate engines or flaring in the atmosphere. In the case of flare, the auto ignition temperature of H_2S is 260°C and that for CH_4 is 595°C thus, well before ignition of CH_4 the H_2S is disintegrated and the foul odour aspect is not relevant.

In the case of feeding into engines, the H_2S in the presence of moisture gets converted to sulphurous acid, which is corrosive and damages the burner hence, the removal of this, is essential before using the gas in engines. It is not that it has to be eliminated fully. Engines can generally tolerate up to about 200 ppm of this gas volume by volume. The permissible concentration of sulphates in drinking water is 200 mg/l and the limit permissible when alternate sources are not available is 400 mg/l. Thus, wherever STPs are planned, the issue of sulphates in raw sewage would appropriately dictate the need for the removal of sulphide in case the biomethanation route and electricity generation from engines is contemplated.

The CMWSSB has installed and is operating three different types of stripping facilities for digester gas in three different STPs. The operating principle of each of these and a summary of observations is compiled in the following section.

6.4.15.3.1 Biochemical Process

The raw biogas containing H_2S is passed through a scrubbing tower from the bottom and the process liquid containing thiobacillus is sprayed from the top. The tower is filled with raschig rings for enhancing the contact between biogas and process liquid whereby, the H_2S is washed and carried away in the liquid and circulated via a reactor tank. The reactions are

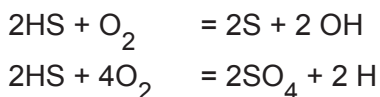


The regeneration of process liquid involves (a) Caustic solution, (b) Nutrient for thiobacillus, (c) Oxygen by way of air and (d) Demineralized water. The process liquid is transferred to a settling tank where the sulphur is stated to be settled and the supernatant flows back to the reactor tank. The settled sulphur is to be pumped to drying beds for recovering elemental sulphur. The controlling parameters are pH, Redox potential and TDS of process liquid. The process units are scrubber tower, reactor tank, settling tank and drying beds.

The process machineries are biogas blower, air blower, spray pump, caustic dosing pumps, measuring pumps and sludge recirculation pumps. An issue is the sludge, which if not used as recovered sulphur would become a hazardous sludge and need secure landfill.

6.4.15.3.2 Biological Process

The biogas containing H_2S is stated to be oxidized to Sulphate according to the equations by using the sulphur oxidizing thiobacillus organisms grown on fluidized media in the tower.



The process units involved are packing media in the tower for growth of thiobacillus, air supplying blower, recirculation pump to provide moisture for the bacteria and nutrient feed pump for maintaining the nitrogen, potassium and phosphorous balance. The removed H_2S ends up as the dissolved sulphate in the product residue stream which is returned to the inlet of the STP.

The issue of importance is the Stoichiometric increment in SO_4 hence, the TDS in the final treated sewage may not be significant as the H_2S itself is derived from the SO_4 present in the raw sewage. The system is provided with its SCADA.

6.4.15.3.3 Chemical Process

The biogas containing the H_2S is first passed through a venturi scrubber sprayed with caustic solution at two or three stages under pressure followed by a second in a counter current packed bed tower filled with porous raschig rings and the H_2S gets dissolved into the caustic and water.

The water coming out of the scrubber will be acidic and is treated with caustic solution which is re-circulated again.

The scrubbed gases are drawn through induced draft fan and forced into the downstream engines. The venturi as well as the packed towers is mounted on the same reservoir and the two liquids are segregated by compartments and individual recirculation pumps are provided, which circulate the liquids till they reach saturation.

The units are venturi scrubber, packed bed tower, water circulation tank, water circulation pump, chemical dosing system comprising dosing pumps and pH controller, dosing pumps for chemical storage tanks, water circulation pipe with valves, fittings and controls. The system has a custom built instrumentation unit for control.

6.4.15.3.4 Observations of the Systems

The results of performance of the three systems as functioning at the STPs of CMWSSB are compiled in Table 6.10. The installations are shown in Figure 6-14 overleaf.

Table 6.10 Observed performances of the three systems for removing H₂S gas

No.	Parameter	Inlet	Representative values in the processes
1	CH ₄ %	60 to 63	64.00 to 70.20
2	CO ₂ %	20 to 28	20.51 to 27.20
3	Hydrogen %	Nil to 2	Trace to 7.20
4	Nitrogen %	1.3 to 6.4	1.1 to 6.8
5	Oxygen %	0.5 to 1.2	0.40 to 2.25
6	H ₂ S ppm	200 to 500	10 - 20 ppm
7	Moisture %	varying	About 50 ppm
8	Calorific value	4,400 to 4,800	5,500 to 5,800 kcal/nm ³

6.4.15.3.5 Appraisal of the Systems in Terms of O&M

The chemical system is the oldest and the bio chemical system is the next generation with the biological system as the recent system. In terms of relative comparison, the biological system has least residues, but has to be maintained and managed carefully for the thiobacillus biomass to be maintained with respect to its nutrient requirements and the avoiding of the media getting too much growth thereon and getting clogged.

The bio-chemical system uses the porous raschig rings and to that extent, its excessive growth and clogging is a matter of concern and nutrient addition is also to be maintained.

The recovery of elemental sulphur, for example, if the raw sewage has a SO₄ concentration of 300 mg/l, the elemental sulphur recovery even at 100% can be about 100 kg/MLD, but the aspects of its purity and consistent yield are to be critically rated.

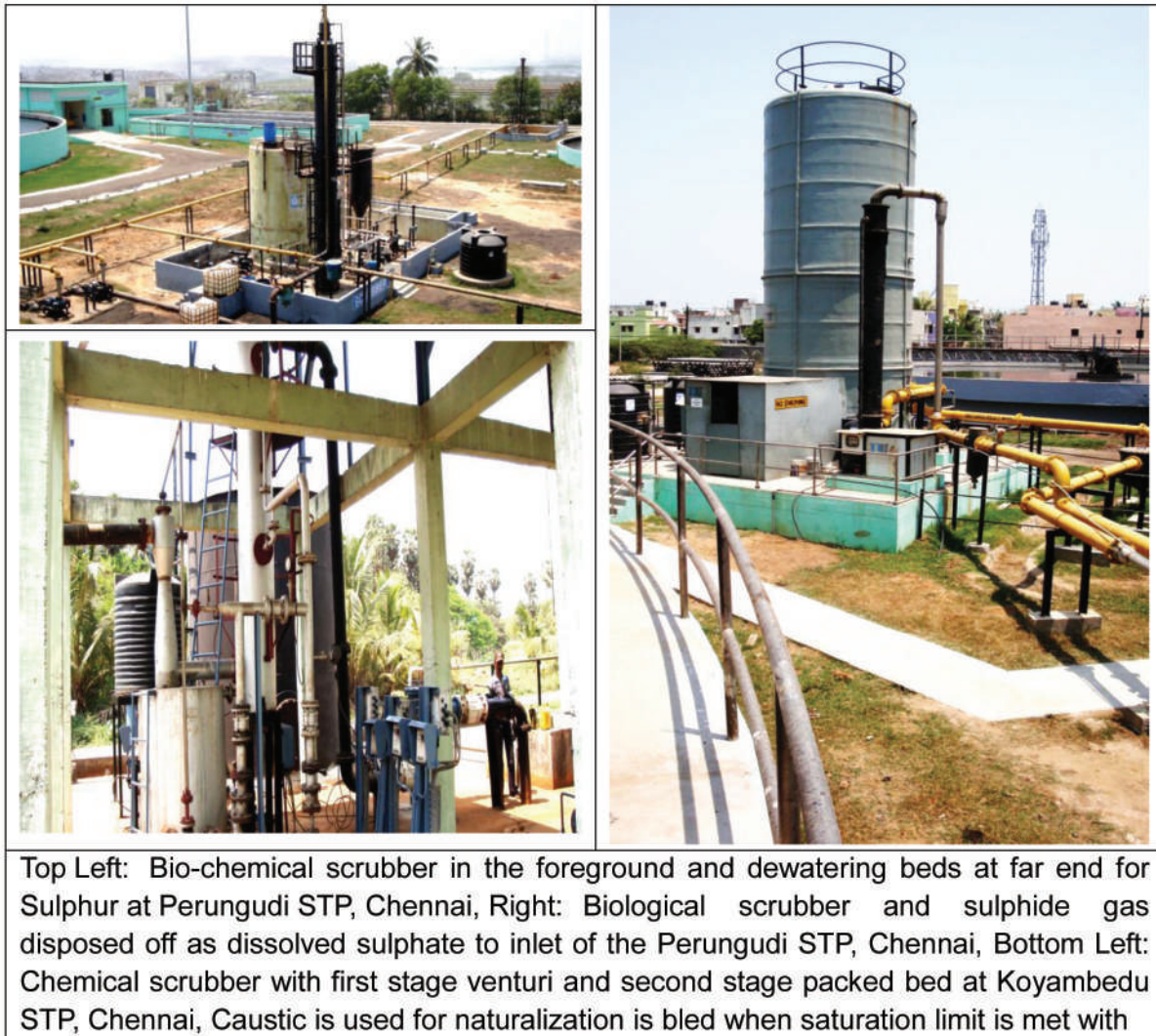


Figure 6.14 Digester gas stripping systems in use for stripping hydrogen sulphide.

Moreover, if the H_2S cannot be reduced fully the foul odour may persist. Upsets in biological sustainability is a common factor for both these processes. The chemical process has the advantage of not relying on the microbial population and its control, but the potential to achieve a 100% stripping of H_2S demands a continuous monitoring and day-to-day adjustments of chemical dosages, which is further compounded by variations in raw sewage quality and hence, variations in sludge gas produced.

Between the biological and chemical processes, relatively higher electrical consumption and feed of caustic are to be considered. Each system needs to be evaluated for the given project on hand.

6.5 AEROBIC SLUDGE DIGESTION

6.5.1 General

Aerobic digestion is also a useful method of stabilizing sewage sludge. It can be used for secondary tank humus or for a mixture of primary and secondary sludge, but not for primary sludge alone. The advantages of aerobic digestion over the anaerobic digestion are listed overleaf:

- 1) lower BOD concentration in digester supernatant
- 2) odourless and easily de-watered biologically stable digested sludge
- 3) recovery of more basic fertilizer value in the digested sludge
- 4) lower capital cost and
- 5) fewer operational problems

Due to these advantages, aerobic digesters are being increasingly used particularly in small STP. However, operating cost in terms of the power cost is much higher than for anaerobic digesters.

The factors that should be considered in designing an aerobic digester include detention time, loading criteria, oxygen requirement, mixing and process operation. The volatile solids destroyed in aerobic digestion in 10 to 12 days at a temperature of 20°C would be 35 to 45%.

Higher temperature will result in reduction in the period of digestion. Oxygen requirements normally vary between 1.7 to 1.9 gm / gm of volatile solids destroyed. It is also desirable to maintain the dissolved oxygen between 1 to 2 mg/l in the system. Operational difficulties may be expected if compressed aeration is practiced. Extended aeration system including oxidation ditches are examples of aerobic digestion. Mechanical or jet aerators or sparger systems are preferable.

6.5.2 Tank Capacity

6.5.2.1 Volume Required

The following digestion tank capacities are based on a solids concentration of 2% with supernatant separation performed in a separate tank. If supernatant separation is performed in the digestion tank, a minimum of 25% additional volume is required. These capacities shall be provided unless sludge thickening facilities are utilized to thicken the feed solids concentration to greater than 2%. If it is provided, the digestion volumes may be decreased proportionally. The sludge source and volume/population equivalent is in Table 6.11.

Table 6.11 Sludge source and volume/population equivalent

Sludge Source	(m ³ /P.E.)
Waste activated sludge - no primary settling	0.13 (A)
Primary plus waste activated sludge	0.11 (A)
Waste activated sludge excluding primary sludge	0.06 (A)
Extended aeration activated sludge	0.09
Primary & attached growth biological reactor sludge	0.09

Note: (A) These volumes also apply to waste activated sludge from single stage nitrification with less than 24 hours detention time based on design average flow;

P.E.-population equivalent as design flow divided by per capita sewage flow.

6.5.2.2 Effect of Temperature on Volume

The volumes in Section 6.5.2.1 are based on digester temperatures of 15°C and a solids retention time of 27 days. Aerobic digesters should be covered to minimize heat loss for colder temperature applications. Additional volume or supplemental heat may be required if the land application method is used. Refer to Section 6.5.9 for necessary sludge storage.

6.5.3 Mixing

Aerobic digesters shall be provided with mixing equipment which can maintain solids in suspension and ensure complete mixing of the digester contents.

6.5.4 Air Requirements

Sufficient air shall be provided to keep the solids in suspension and maintain dissolved oxygen between 1 mg/l and 2 mg/l. For minimum mixing and oxygen requirements, an air supply of 0.5 l/(m³ s) of tank volume shall be provided with the largest blower out of service. If diffusers are used, the non-clog type is recommended and they should be designed to permit continuity of service.

If mechanical turbine aerators are utilized, at least two turbine aerators per tank shall be provided to permit continuity of service.

Mechanical aerators are not recommended for use in aerobic digesters where freezing conditions will cause ice build-up on the aerator and support structures.

6.5.5 Supernatant Separation

Facilities shall be provided for effective separation or decanting of supernatant. Separate facilities are recommended; however, supernatant separation may be accomplished in the digestion tank provided additional volume is provided as per Section 6.5.2. The supernatant draw-off unit shall be designed to prevent return of scum and grease back to plant process units. Provision should be made to withdraw supernatant from multiple levels of the supernatant withdrawal zone.

6.5.6 Scum and Grease Removal

Facilities shall be provided for the effective collection of scum and grease from the aerobic digester for final disposal and to prevent its return to the plant process and to prevent long term accumulation and potential discharge in the effluent.

6.5.7 High Level Emergency Overflow

A high level overflow without any valve and all necessary piping shall be provided to return the digester overflow to the head of the plant or to the aeration process in case of accidental overfilling.

Design considerations related to the digester overflow shall include waste sludge rate and duration during the period the plant is unattended, potential effects on plant process units, discharge location of the emergency overflow and potential discharge of suspended solids in the plant effluent.

6.5.8 Aerobic Digestion Sludge Production

For calculating sludge handling and disposal needs, sludge production values from aerobic digesters shall be based on a maximum solids concentration of 2 % without additional thickening.

The solids production on dry weight basis shall be as follows.

Primary plus waste activated sludge - at least 0.07 kg/(Population Equivalent per day).

Primary plus fixed film sludge - at least 0.05 kg/(Population Equivalent per day).

6.5.9 Digested Sludge Storage Volume

6.5.9.1 Sludge Storage Volume

Sludge storage must be provided in accordance with Section 6.2.7 to accommodate daily sludge production volumes and as an operational buffer for unit outage and adverse weather conditions. Designs utilizing increased sludge age in the activated sludge system as a means of storage are not acceptable.

6.5.9.2 Liquid Sludge Storage

Liquid sludge storage facilities shall be based on the following values unless digested sludge thickening facilities are utilized (refer to Section 6.3) to provide solids concentrations of greater than 2%. The sludge source and volume / population equivalent is given in Table 6.12.

Table 6.12 Sludge source and volume/population equivalent

Sludge Source	m ³ /(P.E.)
Primary plus waste activated sludge (WAS), extended aeration WAS	0.004
Waste activated sludge exclusive of primary sludge	0.002
Primary plus attached growth biological reactor sludge	0.003

P.E.-population equivalent as design flow divided by per capita sewage flow.

6.6 SLUDGE DRYING BEDS

6.6.1 Applicability

This method can be used in all places where adequate land is available and dried sludge can be used for soil conditioning. Where digested sludge is deposited on well drained bed of sand and gravel, the dissolved gases tend to buoy up and float the solids leaving a clear liquid at the bottom, which drains through the sand rapidly.

The liquid drains off in a few hours after which drying commences by evaporation.

The sludge cake shrinks producing cracks, which accelerates evaporation from the sludge surface. The areas having greater sunshine, lower rainfall and lesser relative humidity, the drying time may be about two weeks while in other areas, it could be four weeks or more. Covered beds are not generally necessary.

6.6.2 Unit Sizing

The sludge drying process is affected by weather, sludge characteristics, system design (including depth of bed) and length of time between scraping and lifting of sludge material. High temperature and high wind velocity improve drying, while high relative humidity and precipitation retard drying.

6.6.2.1 Area of Beds

The area needed for dewatering and drying the sludge is dependent on the volume of the sludge, cycle time required to retain sludge for dewatering, drying and removal of sludge and making the sand bed ready for next cycle of application and depth of application of sludge on drying bed. The cycle time between two drying cycles of sludge on drying beds primarily depends on the characteristics of sludge including factors affecting its ability to allow drainage and evaporation of water, the climatic parameters that influence evaporation of water from sludge and the moisture content allowed in dried sludge. The cycle time may vary widely, lesser time required for aerobically stabilized sludge than for anaerobically digested sludge and for hot and dry weather conditions than for cold and/or wet weather conditions.

The area of land required for sludge can be quite substantial with values of 0.1 to 0.25 m³/capita being reported for anaerobically digested sludge under conditions that are unfavourable for dewatering and drying. The average cycle time for drying may range from a few days to 2 weeks in warmer climates to 3 to 6 weeks or even more in unfavourable ones. The worked out example is presented at Appendix A.6.5.

6.6.3 Percolation Type Bed Components

A sludge drying bed usually consists of a bottom layer of gravel of uniform size over which, a bed of clean sand is laid. Open jointed tile under drains are laid in the gravel layer to provide positive drainage as the liquid passes through the sand and gravel.

6.6.3.1 Gravel

Graded gravel is placed around the under drains in layers up to 30cm with a minimum of 15 cm above the top of under drains. At least 3 cm of the top layer shall be gravel of 3 mm to 6 mm.

6.6.3.2 Sand

Clean sand of effective size of 0.5 mm to 0.75 mm and uniformity coefficient not greater than 4.0 is used. The depth of sand may vary from 20 cm to 30 cm. The finished sand shall be levelled.

6.6.3.3 Under Drains

Under drains are made of vitrified clay pipes or tiles or other suitable materials of at least 10 cm diameter laid with open joints. Under drains shall not be more than 6 m apart.

6.6.3.4 Walls

Walls shall preferably be of masonry and extend at least 40 cm above the sand surface. Outer walls should be kerbed to prevent washing outside soil on to beds.

6.6.3.5 Dimensions

Drying beds are commonly 6 m to 8 m wide and 30 to 45 m long. A length of 30 m away from the inlet should not be exceeded with a single point of wet sludge discharge, when the bed slope is about 0.5 %. Multiple discharge points may be used with large sludge beds to reduce the length of wet sludge travel.

6.6.3.6 Sludge Inlet

All sludge pipes and sludge inlets are so arranged to easily drain and have a minimum of 200 mm diameter terminating at least 30 cm above the sand surface. Splash plates should be provided at discharge points to spread the sludge uniformly over the bed and to prevent erosion of the sand.

6.6.3.7 Cover

Sludge drying bed in high rainfall areas in the country needs cover with FRP etc., in accordance with requirement.

6.6.3.8 Drainage

Drainage from beds should be returned to the primary settling units if it cannot be satisfactorily disposed of otherwise.

6.6.4 Sludge Removal

6.6.4.1 Preparation of Bed

Sludge drying beds should be prepared well in advance of the time of application of a fresh batch of sludge. All dewatered sludge, which has formed a cake, should be removed by rakes and shovels or scrapers, care being taken not to pick up sand with the sludge.

After the complete removal of sludge cake, the surface of the bed is cleaned, weeds and vegetation removed, the sand levelled and finally the surface properly raked before adding the sludge. The raking reduces the compaction of the sand and improves the filterability of the bed.

Only properly digested sludge should be applied to the drying beds.

Poorly digested sludge will take a much longer time for dewatering. Sludge containing oils, grease and floating matter clog the sand and interfere with percolation.

Sludge samples from the digester should be examined for the physical and chemical characteristics to ensure that it is ready for withdrawal.

6.6.4.2 Withdrawal of Sludge

Sludge should be withdrawn from the digester at a sufficiently high rate to clear the pipeline. Rodding and back-flushing of the inlet pipe may sometimes become necessary to make the material flow easily. Valves must be opened fully to start with and later adjusted to maintain regular flow. The flow may be regulated to keep the pipe inlet from being submerged. Naked flames should be prohibited while opening sludge valves and exposed discharge channels.

6.6.4.3 Removal of Sludge Cake

Dried sludge cake can be removed by shovel or forks when the moisture content is less than 70 %. When the moisture content reaches 40 % the cake becomes lighter and suitable for grinding. Some sand always clings to the bottom of the sludge cake and results in loss of sand thus reducing the depth of the bed. When the depth of the bed is reduced to 10 cm, clean coarse sand that matches the original sand already in the bed should be used for replenishment to the original depth of the bed.

6.6.4.4 Hauling and Storage of Sludge Cakes

Wheel barrows or pickup trucks are used for hauling of sludge cakes. In large plants mechanical loaders and conveyors may be required to handle large quantities of dried sludge. Sludge removed from the bed may be disposal of directly or stored to make it friable, thereby improving its suitability for application to soil.

6.7 SLUDGE DEWATERING

6.7.1 General

Most of the digested primary or mixed sludge can be compacted to a water content of about 90% in the digester itself by gravity, but mechanical dewatering with or without coagulant aids or prolonged drying on open sludge drying beds (SDB) may be required to reduce the water content further. The dewatering of digested sludge is usually accomplished on SDB, which can reduce the moisture content to below 70% or by mechanical equipment. However, excess oil or grease in the sludge will interfere with the process. Where the required space for SDB is not available, sludge conditioning, followed by mechanical dewatering in vacuum filters, filter presses or centrifugation followed by heat drying or incineration can be adopted. In most parts of the country, the climate is favourable for open SDB, which is economical and easy to manage.

Dewatering methods include filtration and mechanical separation. Filtration may be performed by pressure filtration or filtration by belt press filter, pressure filter, vacuum filter, screw press dewatering equipment and multi disc dehydrator. Of these, the dewatering performance and operability and maintainability (especially increase in dewatered sludge) of pressure filter and vacuum filter are inferior compared to those of other systems; therefore, instances of using these together have reduced, and in recent years, there are practically no instances of adoption of new pressure and vacuum filters.

In recent years, modifications have been made to screw press dewatering equipment, and these are being used in small-scale facilities.

6.7.2 Features

Vacuum filtration is the most common mechanical method of dewatering, with filter presses and centrifugation being the other methods. Chemical conditioning is normally required prior to mechanical methods of dewatering. Mechanical methods may be used to dewater raw or digested sludge preparatory to heat treatment or before burial or landfill. Raw sludge is more amenable to dewatering by vacuum filtration because the coarse solids are rendered fine during digestion. Hence, filtration of raw primary mixture of primary and secondary sludge permits slightly better yields, lower chemical requirement and lower cake moisture contents than filtration of digested sludge. When the ratio of secondary to primary sludge increases, it becomes more and more difficult to dewater in the filter. The feed solids concentration has a great influence, the optimum being 8% to 10%. Beyond 10% sludge becomes too difficult to pump and lower solids concentration would demand unduly large filter surface. In this method, conditioned sludge is spread out in a thin layer in the filtering medium, the water portion being separated due to the vacuum and the moisture content is reduced quickly.

6.7.3 Dewatering Principle

Belt press filter comprises two mechanisms; filtering and dewatering by compression. The gravity dewatering part in a belt press filter corresponds to the filter, while the compression part corresponds to dewatering by compressing the sludge. The centrifugal dewatering machine performs dewatering by solid-liquid separation by centrifugal force.

The filtration rate can be expressed by the flow rate of the filtrate. The filtration rate per unit filter area can be expressed by pressure and filtration area.

Dewatering by compression between rolls consists of compressing air gaps in the dewatered sludge and squeezing out the pore water.

The centrifugal separation characteristics vary according to the diameter of particles in sludge, density and mixing action. Centrifugal dewatering machines may be classified according to the solids separating function and the dewatering function that reduces the water content of solids that are settled and separated.

6.7.4 Sludge Conditioning

Thickened sludge and digested sludge includes large amount of organic matter with high affinity to water; moreover, the sludge has particles of various sizes and shapes, so the sludge is difficult to compress and dewatering the sludge as-is, is difficult.

To improve dewatering of the sludge, the quality of sludge should be improved physically and chemically before dewatering it and sludge should be conditioned with the aim of stabilizing its properties and coagulating it. In recent years, treatment plants have been adopting the so-called separation and thickening method in which, the primary sludge is thickened by gravity with mechanical thickening method used for excess sludge.

This method is being increasingly used because of the difficulty in thickening sludge generated from treatment systems. In such cases also, sludge conditioning is necessary for stabilizing sludge properties by uniformly mixing two kinds of sludge with varying properties. Sludge conditioning includes mixing of sludge, elutriation of sludge and adding of coagulant. Sludge mixing refers to the quantitative mixing of two or more kinds of sludge with varying properties based on the generated solids volume ratio to achieve consistency.

For elutriation of sludge, the digested sludge is elutriated with secondary treated water and the alkalinity of sludge is reduced so that the usage of coagulants can be reduced. It is often omitted when organic coagulants are used in the dewatering process. Chemical addition combines fine particles in sludge and makes solid-liquid separation easy, generates floc, and improves dewatering of sludge. Coagulants used may be organic or inorganic.

Coagulants are determined by the kind of dewatering machine used. That is, inorganic coagulants are used in vacuum filters and pressure filters, while organic coagulants are used in belt press filters, centrifugal dewatering machines and screw press dewatering machines. In recent years, belt press filters and centrifugal dewatering machines are mostly adopted and organic coagulants are widely used.

Prior conditioning of sludge before application of dewatering methods renders it more amenable to dewatering. Chemical conditioning and heat treatment are the two processes normally employed.

6.7.4.1 Chemical Conditioning

Chemical conditioning is the process of adding certain chemicals to enable coalescence of sludge particles facilitating easy extraction of moisture. The chemicals used are ferric and aluminium salts and lime, the more common being ferric chloride with or without lime. Digested sludge, because of its high alkalinity exerts a huge chemical demand and therefore, the alkalinity has to be reduced to effect a saving on the chemicals. This can be accomplished by elutriation.

Polyelectrolyte is useful for sludge with finely dispersed solids. The choice of chemical depends on pH, ash content of sludge, temperature and other factors. Optimum pH values and chemical dosage for different kinds of sludge has to be based on standard laboratory tests.

The dosage of ferric chloride and alum for elutriated digested sludge is 1.0 kg/m^3 of sludge.

Alum when vigorously mixed with the sludge reacts with the carbonate salts and release CO_2 , which causes the sludge to separate and water drains out more easily. Hence, for effective results, alum must be mixed quickly and thoroughly. The alum floc, however, is very fragile and its usefulness has to be evaluated vis-a-vis ferric chloride before resorting to its application.

Feeding devices are necessary for applying chemicals. Mixing of chemicals with sludge should be gentle, but thorough, taking not more than 20 to 30 seconds. Mixing tanks are generally of the vertical type for the small plants and of the horizontal type for large plants. They are provided with mechanical agitators rotated at 20 rpm to 80 rpm.

6.7.4.2 Use of Polyelectrolytes

In the use of mechanical dewatering of digested sludge, equipment such as filter press and centrifuge are relatively popular in usage. The performance of these would however be enhanced if the feed sludge is conditioned by use of polyelectrolyte. It is difficult to specify any formula suitable for a polyelectrolyte. Even though there are quite a few such polyelectrolytes in the market, it is best to carry out an actual laboratory scale testing before launching into the procurement. In general, polyelectrolytes are available in both powder form and viscous liquid form. In essence both are same as far as usage is concerned, because the powder immediately on being added to water will also become viscous. Usually the dosage needed is expressed as kg of polyelectrolyte needed for ton of dry solids in the sludge to be conditioned for subsequent mechanical dewatering.

The solution for dosing is mostly a 0.1% solution and is injected into the feed line to dewatering equipment with adequate length and velocity ahead of the dewatering equipment. The type of pump which can be generally suitable is the diaphragm pump powered by a reciprocating shaft of a push-pull motion, which injects the calculated dosages as intermittent jets. Peristaltic pump sets are also used sometimes when the viscosity of the feed sludge solution is not very high. In all cases, actual on-site treatability evaluation is called for in respect of choice of polyelectrolytes.

6.7.4.3 Elutriation

The purpose of elutriation of sludge is to reduce the coagulant demand exerted by the alkalinity of the digested sludge, by dilution with water of lower alkalinity followed by sedimentation and decantation. Some end products of digestion such as ammonium bicarbonate, which exert increased demand of chemicals in conditioning, are removed in the process.

There are three methods of elutriation: single stage, multi-stage and counter-current washing, the water requirement being dependent upon the method used. For a given alkalinity reduction, single stage elutriation requires 2.5 times as much water as the two stage and 5 times as much water as counter-current washing. Hence, single stage washing is used only in small plants.

Counter-current washing, although higher in initial cost, is adopted in all large plants. Water requirement also depends on alkalinity of dilution water, alkalinity of sludge and desired alkalinity of elutriated sludge. Sludge and water are mixed in a chamber with mechanical mixing arrangement, the detention period being about 20 seconds. The sludge is then settled in settling tanks and excess water decanted. A maximum surface loading on settling tank of about $40\text{m}^3/\text{m}^2/\text{day}$ and a detention period of about 4 hours are adopted.

Counter-current elutriation is generally carried out in twin tanks similar to sedimentation tanks, in which sludge and wash water enter at opposite ends. Piping and channels are so arranged that wash water entering the second stage tank comes first in contact with sludge already washed in the first stage tank. The volume of wash water required is roughly 2 to 3 times the volume of sludge elutriated.

The dosage of chemicals detention period and flow of conditioned sludge to mechanical dewatering units are automatically controlled by float switches, so that these variables are adjusted on the basis of performance and the quality of sludge cake coming out.

6.7.4.4 Heat Treatment

In this process, sludge is heated for short periods of time under pressure. Sludge is preheated in a heat exchanger before it enters a reactor vessel where steam is injected to bring the temperature to 145°C to 200°C at a pressure of 10 to 15kg/cm². After a 30-minute contact time, the sludge is discharged through the heat exchanger to a sludge separation tank. The sludge can be filtered through a vacuum filter to a solid content of 40% to 50% with filter yields of 100 kg/m³/hr.

6.7.5 Screw Press

There are presently two major types of screw presses used in municipal dewatering applications: horizontal and inclined. Inclined screw presses are at angles 15 to 20 degrees from the horizontal. Other areas of difference pertain to sludge inlet configuration, screen basket design (wedge wire), basket cleaning from the inside and outside (brushes and rotating wash system) and filtrate water collection.

The major elements of a screw press dewatering system are the sludge feed pump, polymer makeup and feed system, polymer injection and mixing device (injection ring and mixing valve), flocculation vessel with mixer, sludge inlet headbox or pipe, screw driver mechanism, shafted screw enclosed within a screen, a rectangular or circular cross-section enclosure compartment, and an outlet for dewatered cake. Some horizontal screw press systems (e.g., the combined dewatering and pasteurization process) include a rotary screen thickener before the screw press, which may be desirable for reducing the hydraulic load to the screw press given certain feed sludge characteristics in conventional applications.

A screw press is a simple, slow moving device that achieves continuous dewatering. Polymer is combined with sludge in flocculation vessels upstream of the screw press to enhance the sludge's dewatering characteristics. Screw press dewater sludge first by gravity drainage at the inlet section of the screw and then by squeezing free water out of the sludge as they are conveyed to the discharge end of the screw under gradually increasing pressure and friction. The increased pressure to compress the sludge is generated by progressively reducing the available cross-sectional area for the sludge. The released water is allowed to escape through perforated screens surrounding the screw, while the sludge is retained inside the press. The liquid forced out through the screens is collected and conveyed from the press and the dewatered sludge is dropped through the screw's discharge outlet at the end of the press. The screw speed, configuration, screen size and orientation can be tailored for each application. The machine is shown in Figure 6.15 overleaf.

Advantages

- 1) Low rotational speed results in low maintenance and noise.
- 2) Low operating energy consumption
- 3) Containment of odours and aerosol, low building corrosion potential
- 4) Simple operation with low operator attention
- 5) Wash water demand and pressure requirements lower than belt presses.



Source: ISHIGAKI COMPANY, LTD

Figure 6.15 Screw press dewatering machine

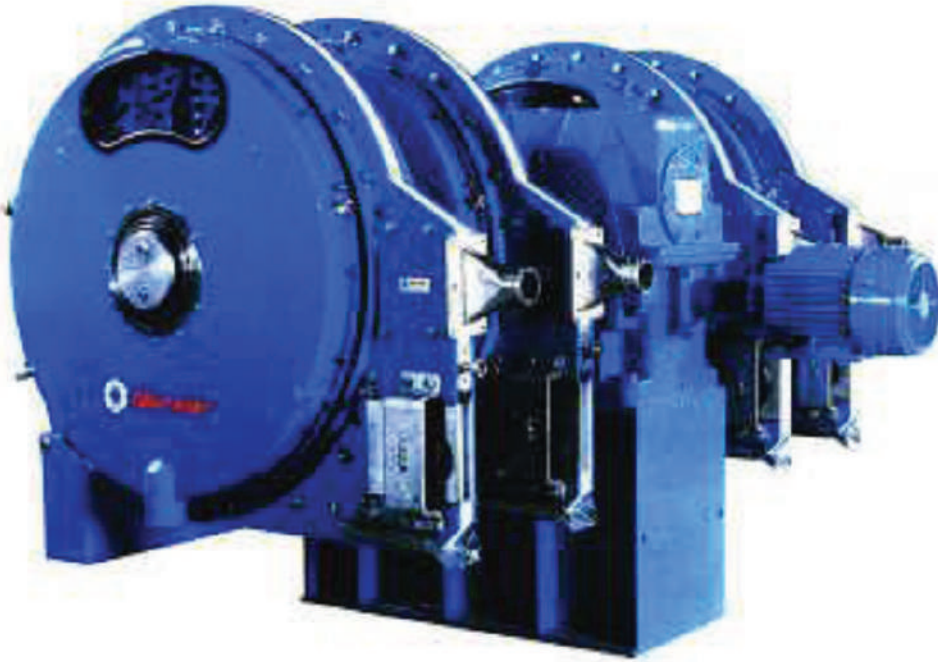
Disadvantages

- 1) Cake concentration may be relatively low when there are no primary clarifiers.
- 2) Larger footprint
- 3) Only few manufacturers are available and equipment cannot be specified “as-equal.” It must be sole-sourced or pre-purchased.
- 4) Requires wash water
- 5) Lower solids capture than other dewatering processes in some cases.

6.7.6 Rotary Press

Rotary press dewatering technology relies on gravity, friction, and pressure differential to dewater sludge. Sludge is dosed with polymer and fed into a channel bound by screens on each side. The channel curves with the circumference of the unit, making a 180° turn from inlet to outlet. Free water passes through the screens, which move in continuous, slow, concentric motion. The motion of the screens creates a “gripping” effect toward the end of the channel, where cake accumulates against the outlet gate, and the motion of the screens squeezes out more water. The cake is continuously released in pressure-controlled outlet.

The major elements of a rotary press are the polymer feed and mixing system, parallel filtering screens, a circular channel between the screens, the rotation shaft and a pressure-controlled outlet. The screens consist of two layers of perforated stainless steel, with each layer having different sieve size. The rotary press drive configuration allows up to six rotary press channels to be operated on a single drive. Each channel has bearings and the combined unit has an outboard bearing cantilevered on one end. The rotary press dewatering machine is shown in Figure 6.16 overleaf.



Source: Sanki Engineering Co., Ltd.

Figure 6.16 Rotary press dewatering machine (1,200φ, 4 channels)

Advantages

- 1) Uses less energy than centrifuges or belt filter presses
- 2) Small footprint
- 3) Odours contained
- 4) Low shear
- 5) Minimal moving parts
- 6) Minimal building requirements
- 7) Minimal start-up and shutdown time
- 8) Uses less wash water than belt filter presses
- 9) Low vibration, low noise
- 10) Modular design

Disadvantages

- 1) May be more dependent on polymer performance than centrifuges or belt filter presses
- 2) Low throughput compared to other mechanical dewatering processes
- 3) Screen clogging potential
- 4) Need for heavy rated overhead crane to lift and maintain channels
- 5) High capital cost

6.7.7 Belt Press

Belt filter presses continuously dewater sludge using two or three moving belts and a series of rollers. The filter belt separates water from sludge via gravity drainage and compression. Sludge sandwiched between two tensioned porous belts is passed over and under rollers of various diameters. Increased pressure is created as the belt passes over rollers which decrease in diameter. Many designs of belt filtration processes are available, but all incorporate the following basic features: polymer conditioning zone, gravity drainage zones, low pressure squeezing zone and high pressure squeezing zones.

Each belt press manufacturer produces machines with slightly different mechanical features and operating characteristics. Presses are available in widths ranging from about 0.5 m to 3.5 m. Most belt filter press in municipal STP use belts of 1 m to 2 m width. The main components of a belt filter press include feed equipment and piping frame, belts, belt-tracking and tensioning systems, belt wash system, rollers and bearings, cake-discharge blades, chutes, cake conveyance, drive system, belt-speed control and chemical conditioning and flocculation as in Figure 6.17.

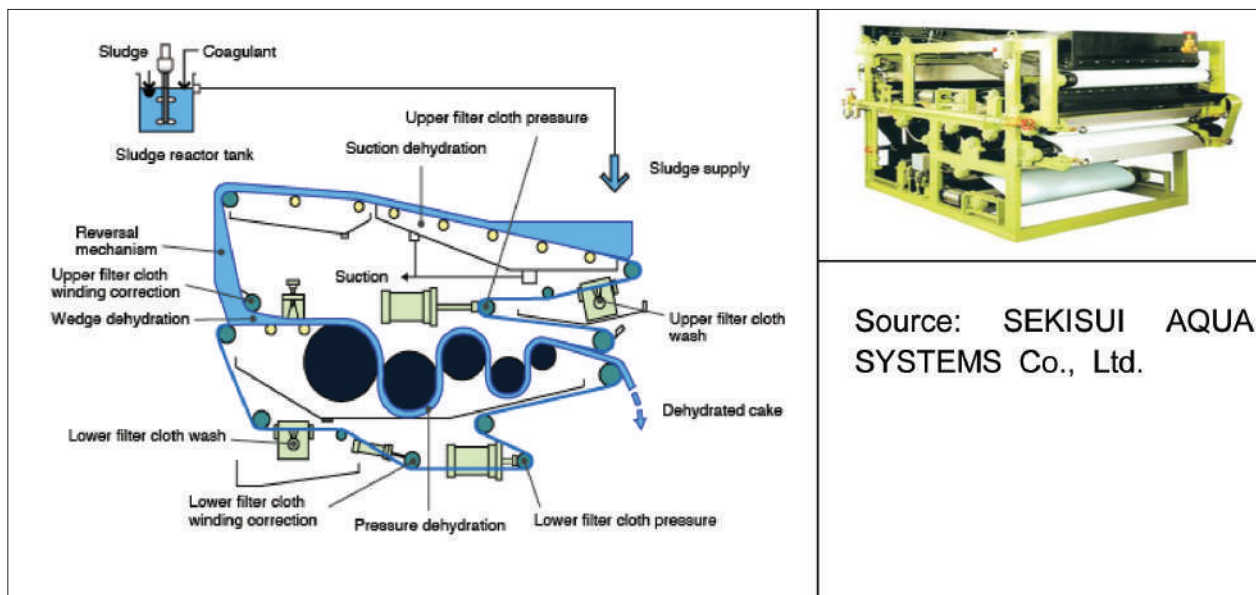


Figure 6.17 Belt press dewatering machine

Personnel safety must be fully considered and incorporated into the design. The design must provide for and facilitate maintenance, provide safety stops, for instance with ultraviolet sensor and trip wires around the belt press and any cake conveyors, convenient and safe equipment access, drainage and spill containment, non-slip walkways and floors, sufficient lighting, noise reduction, ventilation and odour control. System interlocks should be provided to stop the solids and polymer feed pumps when the press is shut down.

Advantages

- 1) Staffing requirements are low, especially if the equipment processes the solids in one shift

- 2) Maintenance is relatively simple and can usually be completed by a sewage treatment plant maintenance crew.
- 3) Energy requirements are relatively low compared to some other types of dewatering equipment
- 4) Belt presses can be started and shut down quickly compared to centrifuges, which require up to an hour to build up speed
- 5) There is less noise associated with belt presses compared to centrifuges

Disadvantages

- 1) Because of the open nature of a belt press, there is a significant potential for odours and sprays. Workers in the belt press areas can be exposed to aerosols from the belt-wash spray nozzles, as well as pathogens and hazardous gases (e.g., hydrogen sulphide).
- 2) Belt presses require more operator attention if the feed sludge varies in the solids concentration or organic matter. This should not be a problem if the belt presses are fed from well-mixed digesters.
- 3) Sludge with higher concentrations of oil and grease can result in blinding the belt filter and lower solids content cake.
- 4) Sludge must be screened and/or ground to minimize the risk of sharp objects damaging the belt.
- 5) Belt washing at the end of each shift, or more frequently, can be time consuming and require large amounts of water. An automatic belt washing system and the use of effluent can minimize these costs.
- 6) Replacing the belt is the major maintenance cost

6.7.8 Filter Press

Pressure filtration uses a positive pressure differential to separate suspended solids from liquid slurry. Recessed-chamber filter presses are operated as a batch process. Solids pumped to the filter press under pressure ranging from 100 to 300 psi force the liquid through a filter medium, leaving a concentrated solids cake trapped between the filter cloths that cover the recessed plates. The filtrate drains into internal conduits and collects at the end of the press for discharge. Then the plates separate and the cake falls into a conveyor to the collection truck. Two types of filter presses typically are used to dewater sludge.

The most common is the fixed-volume, recessed-chamber filter press. The other is the variable volume, recessed-chamber filter press (also called the diaphragm filter press).

The main mechanical components of filter press include the structural frame, filter press plates, diaphragms, filter cloths and plate sifters. Various options are available for each component.

Advantages

- 1) The main advantage of a pressure filter press system is that it typically produces cakes that are drier than those produced by other dewatering equipments.
- 2) If the cake solids content are more than 35%, then filter presses can be a cost-effective dewatering option.
- 3) Filter press can adapt to a wide range of sludge characteristics.
- 4) Filter press produce a high-quality filtrate that lowers recycle stream treatment requirements.
- 5) Pressure filter press are cost-effective when the dewatered cake are incinerated.

Disadvantages

- 1) The main disadvantages of filter press are their high capital cost, relatively high O&M costs and substantial quantities of treatment chemicals.
- 2) The periodic adherence of cake to the filter medium must be manually removed. This problem may indicate the need to wash the filter media or increase conditioner dosages.
- 3) It requires significant amounts of energy to pressurize the units. Typical energy requirements are in order of 0.04 to 0.07 kWh per kilogram of dry sludge processed.

6.7.9 Centrifugal Dewatering Machine

The process of high speed centrifuging has been found useful to reduce the moisture in sludge to around 60 %. Usually the liquor from the centrifuge has higher solids content than filtrate from sand drying beds. Return of this liquor to the treatment plant may result in a larger recalculated load of these fine solids to the primary settling and sludge system and also in reduced effluent quality.

Advantages

- 1) Centrifuge may offer lower overall operation and maintenance costs and can outperform conventional belt filter presses.
- 2) Centrifuge require a small amount of floor space relative to their capacity.
- 3) Centrifuge require minimal operator attention when operations are stable.
- 4) Low exposure to pathogens, aerosols, hydrogen sulphide or other odours.
- 5) Centrifuge are easy to clean.
- 6) Centrifuge can handle higher than design loadings and the percent solids recovery can usually be maintained with the addition of a higher polymer dosage.
- 7) Major maintenance items can be easily removed and replaced. Repair work is usually performed by the manufacturer.

Disadvantages

- 1) Centrifuge have high power consumption and are fairly noisy.
- 2) Experience of operating the equipment is required to optimize performance.
- 3) Performance is difficult to monitor because the operator's view of centrate and feed is obstructed.
- 4) Special structural considerations must be taken into account. As with any piece of high speed rotary equipment, the base must be stationary and level due to dynamic loading.
- 5) Spare parts are expensive and internal parts are subject to abrasive wear.
- 6) Start-up and shut-down may take an hour to gradually bring the centrifuge up to speed and slow it down for clean out prior to shut-down.

6.7.10 Vacuum Filter

The vacuum filter consists of a cylindrical drum over which a filtering medium of wool, cloth or felt, synthetic fibre or plastic, or stainless steel mesh or coil springs is fixed. The drum is suspended horizontally so that one quarter of its diameter is submerged in a tank containing sludge.

Valves and piping are arranged to apply a vacuum on the inner side of the filter medium as the drum rotates slowly in the sludge. The vacuum holds the sludge against the drum as it continues to be applied as the drum rotates out of the sludge tank. This pulls water away from the sludge leaving a moist cake mat on the outer surface.

The sludge cake on the filter medium is scraped from the drum, just before it enters the sludge tank again. Vacuum pumps, moisture traps, filtrate pumps, filtrate receivers, conveyors and pipes and valves are necessary adjuncts to the filter.

Operating costs of vacuum filters are usually higher than for sludge drying beds. However, they require less area since dewatering is rapid. The operation is independent of weather conditions and it can be used for dewatering raw or partially digested sludge requiring drying or incineration.

The capacity of the filter varies with the type of sludge being filtered and in calculating the size of filter the desired moisture content of the filter cake is a factor.

If wet cake is acceptable, higher filtration rates and lower coagulant dosage can be used. The filtration rate is expressed in kg of dry solids per square meter of medium per hour. It varies from 10 kg/m²/hr for activated sludge alone to 50 kg/m²/hr for primary sludge.

A design rate of 15 kg/m²/hr is a conservative figure that can be used when the quality of the sludge and the type of the filter to be used are not known.

Filter drums are rotated at a speed of 7 rpm to 40 rpm with a vacuum range of 500 mm to 650 mm of mercury. The filter run does not exceed 30 hours per week in small plants to allow time for conditioning, clean up and delays. At larger plants, it may work for 20 hours a day. The moisture of the filtered cake varies normally from 80% in case of raw activated sludge to 70% for digested primary sludge.

Filters should be operated to produce a cake of 60% to 70% moisture if it is to be heated, dried or incinerated. At the end of each filter run, the filter fabric is cleaned to remove sticking sludge.

A high pressure stream of water is used to clean the filter cloth. The filters are usually located in a separate room or building with adequate light and ventilation.

Advantages

- 1) Operation is easy to understand because formation and discharge of sludge cake are easily visible.
- 2) Does not require highly-skilled operator
- 3) Will continue to operate even if the chemical conditioning dosage is not optimized, although this may cause discharge problems
- 4) Has low maintenance requirement for a continuously operating piece of equipment, except in certain cases with lime conditioning

Disadvantages

- 1) Consumes a large amount of energy per unit of sludge dewatered
- 2) Vacuum pumps are noisy.
- 3) Lime and Ferric chloride conditioning can cause considerable maintenance cleaning problems.
- 4) The use of lime for conditioning can produce strong ammonia odours with digested sludge.
- 5) Best performance is usually achieved at feed solids of 3 to 4%. However, some well-conditioned sludge are filtered successfully at concentrations of <2%.
- 6) Ferric chloride and lime conditioning costs are higher than polymer conditioning costs. Polymer conditioning is not always effective on vacuum filters.

6.7.11 Comparison of Dewatering Systems

The advantages and disadvantages of dewatering systems are compared in Table 6.13 overleaf.

6.8 SLUDGE DISINFECTION

6.8.1 Heat Drying

The purpose of heat drying is to reduce the moisture content and volume of dewatered sludge, so that it can be used after drying without causing offensive odours or risk to public health.

Several methods such as sludge drying under controlled heat, flash drying, rotary kiln, multiple hearth furnaces, etc., have been used in combination with incineration devices. Drying is brought about by directing a stream of heated air or other gases at about 350°C.

Table 6.13 Comparison of advantages and disadvantages of dewatering systems

	Advantages	Disadvantages
Screw Press	<ol style="list-style-type: none"> 1) Low rotational speed results in low maintenance and noise. 2) Low operating energy consumption 3) Containment of odours and aerosol, 4) Low building corrosion potential 5) Simple operation with low operator attention 6) Lower wash water and pressure than belt presses. 	<ol style="list-style-type: none"> 1) Cake concentration may be relatively low for primary sludges. 2) Larger footprint 3) Few indigenous manufacturers available as of this time 4) Requires wash water 5) Lower solids capture than other processes in some cases. 6) More dependency on supplier for repairs
Rotary Press	<ol style="list-style-type: none"> 1) Uses less energy than centrifuges or belt filter presses 2) Small footprint, minimum building size, Odours contained, 3) Minimal moving parts, less vibration 4) Minimal start-up and shutdown time 5) Uses less wash water than belt filter presses 	<ol style="list-style-type: none"> 1) More dependent on polymers than centrifuges / belt filter presses 2) Low throughput than other mechanical dewatering processes 3) Screen clogging potential 4) Heavy rated overhead crane to lift and maintain channels 5) Higher building requirements in structural
Belt Press	<ol style="list-style-type: none"> 1) Staffing requirements are less. 2) Maintenance is relatively simple. Belt change is the major cost. 3) Energy is relatively low than some other dewatering equipment. 4) Can be started and shut down quickly compared to centrifuges. 5) Less noise compared to centrifuges. 6) The rotary speed is lesser as compared to centrifuges. 	<ol style="list-style-type: none"> 1) A significant potential for odours and sprays 2) More operator attention when feed sludge contents varies 3) High oil & grease causes blinding the belt and lesser cake solids 4) Sludge to be screened / ground as sharp objects damage to belt 5) Belt washing time consuming and requires more wash water. 6) Roller alignments requires skilled setting in repairs

	Advantages	Disadvantages
Filter Press	<ol style="list-style-type: none"> 1) Produces drier cakes than other dewatering equipment 2) For solids of more than 35 % in cake, they can be cost-effective 3) Can adapt to a wide range of sludge characteristics 4) Produces a high-quality filtrate. Lowers recycle stream treatment 5) Cost-effective when the dewatered cake must be incinerated. 	<ol style="list-style-type: none"> 1) Relatively high O&M costs. 2) Treatment chemicals required 3) Needs periodic manual removal of adherence of cake to the filter 4) Increased washing of filter media or higher conditioner dosages. 5) Requires significant amounts of energy to pressurize the units.
Centrifuges	<ol style="list-style-type: none"> 1) Lower O&M costs and can outperform conventional belt presses 2) Require a small amount of floor space relative to their capacity 3) Require minimal operator attention when operations are stable 4) Low exposure to pathogens, aerosols and odours for operators. 5) Relatively easier to clean in situ 6) Can handle higher than design loadings 7) Solids recovery can be sustained by higher polymer dosage 8) Major maintenance items can be easily removed and replaced. 	<ol style="list-style-type: none"> 1) High power consumption and fairly noisy 2) Experience of operating is required to optimize performance. 3) Difficult to monitor as view of centrate and feed is obstructed. 4) The base must be stationary and level due to dynamic loading. 5) Spare parts are supplier oriented 6) Internal parts are subject to abrasive wear. 7) Start-up and shut down may take an hour. 8) Heavy dependence on supplier for repairs
Vacuum Filter	<ol style="list-style-type: none"> 1) Formation and discharge of sludge cake is easily visible. 2) Operation is easily understood visually 3) Does not require highly-skilled operator attention 4) Will operate even if the chemical dosage is not optimized, 5) Has a low maintenance requirement for a continuously operation 6) Certain cases with lime conditioning may cause O&M issues. 	<ol style="list-style-type: none"> 1) Higher energy per unit of sludge Vacuum pumps are noisy. 2) Lime / Ferric chloride conditioning causes cleaning problems. 3) Lime use can produce strong ammonia smell in digested sludge. 4) Polymer conditioning is not always effective on vacuum filters. 5) Heavy dependence on supplier for repairs to filter medium 6) Alignment of filter medium is crucial after repairs.

The hot gases, dust and ash released during combustion are to be removed by suitable control mechanisms to minimize air pollution. The dried sludge removed from the kilns is granular and clinker-like, which may be pulverized before use as soil conditioner.

6.8.2 Incineration

The purpose of incineration is to destroy the organic material, the residual ash being generally used as landfill. During the process all the gases released from the sludge are burnt off and all the organisms are destroyed. Dewatered or digested sludge is subjected to temperatures between 650°C to 750°C. Cyclone or multiple hearth and flash type furnaces are used with proper heating arrangements with temperature control and drying mechanisms. Dust, fly ash and soot are collected for use as landfill.

It has the advantages of freedom from odours and a great reduction in volume and weight of materials to be disposed of finally, but the process requires high capital and recurring costs, installation of machinery and skilled operation. Controlled drying and partial incineration have also been employed for dewatering of sludge, before being put on drying beds.

6.9 SLUDGE COMPOSTING

6.9.1 Outline

Sludge composting is a method, in which microorganisms decompose the degradable organic matter in sludge under the aerobic condition and create stable material that is easy to handle, store and use for farmland. Sludge compost is humus-like material without detectable levels of pathogens that can be applied as a soil conditioner and fertilizer to gardens, food and feed crops and farmland.

Sludge compost provides large quantities of organic matter and nutrients such as nitrogen and potassium to the soil. It improves the soil texture, elevates soil cation exchange capacity (an indication of the soil's ability to hold nutrients), all characteristics of a good organic fertilizer. Sludge compost is safe to use and generally has a high degree of acceptability by the public.

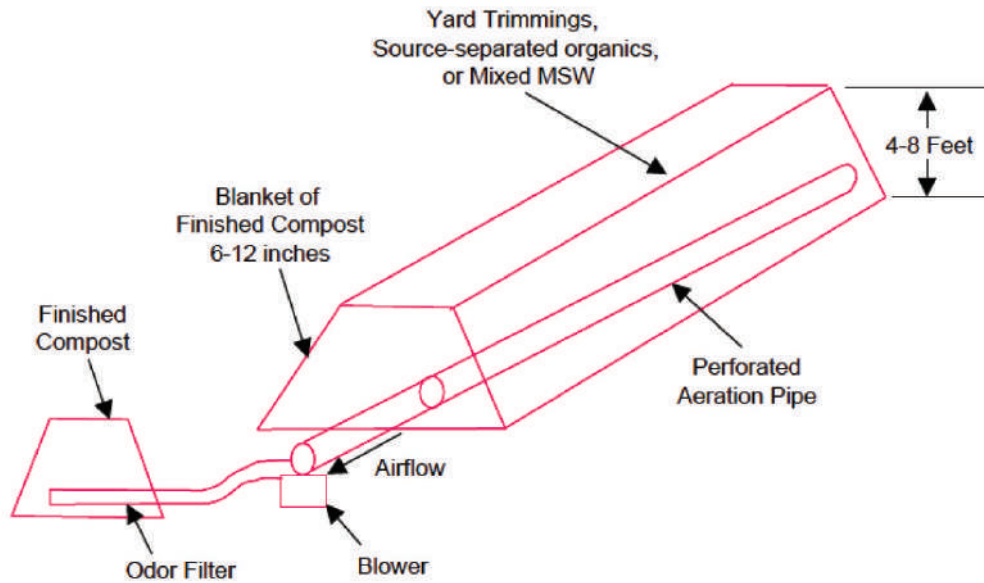
Sludge composting involve mixing dewatered sludge with a bulking agent to provide carbon and increase porosity. The resulting mixture is piled or placed in a vessel where microbial activity causes the temperature of the mixture to rise during the first phase active composting period. The specific temperatures that must be achieved and maintained for successful composting vary based on the method and use of the end product. After the first phase, active composting period of the material is cured and in the second phase, it becomes compost and is distributed.

6.9.2 Types of Composting Methods

Sludge composting methods are divided into, aerated static pile, windrow and in-vessel.

a. Aerated static pile

Figure 6.18 (overleaf) shows an aerated static pile composting method.



Source:Hickman Jr., H.Lanier, 1999

Figure 6.18 Configuration of an aerated static pile composting method

Dewatered sludge cake is mechanically mixed with a bulking agent and stacked into long piles over a bed of pipes, through which air is transferred to the composting material. After the first phase composting i.e., active composting, as the pile is starting to cool down, the material is moved into the second phase composting i.e., a curing pile. The bulking agent is often reused in this composting method and may be screened before or after curing so that it can be reused.

b. Windrow

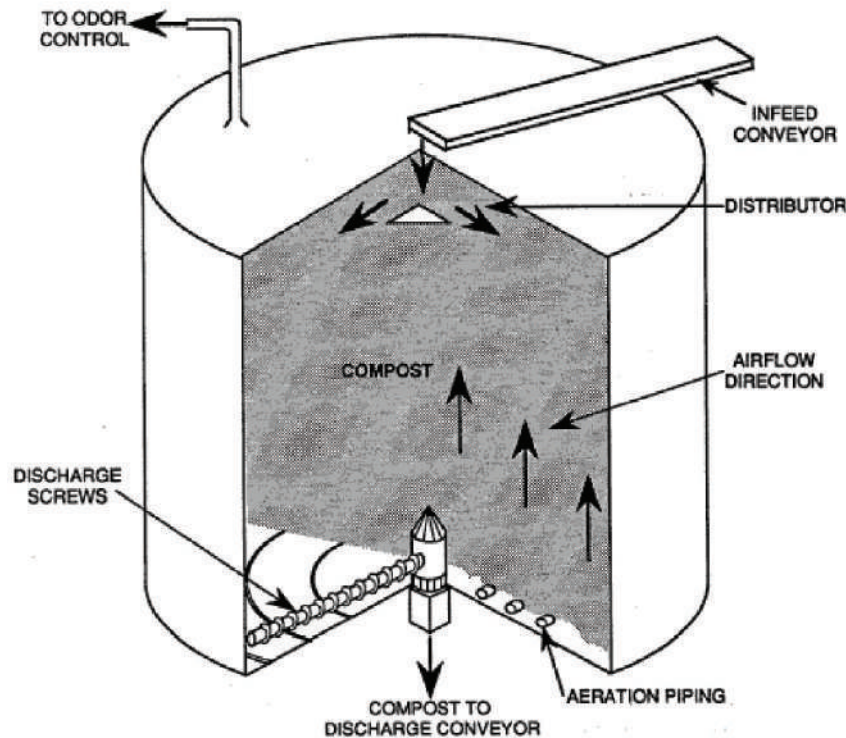
Dewatered sludge cake is mixed with bulking agent and piled in long rows because there is no piping to supply air to the piles; they are mechanically turned to increase the amount of oxygen. This periodic mixing is essential to move outer surfaces of material inward so they are subjected to the higher temperatures deeper in the pile. A number of turning devices are available. As with aerated static pile composting, the material is moved into the second phase composting i.e., curing piles after the first phase composting, it is active composting. Several rows may be placed into a larger pile for curing

c. In-Vessel

There are two types of In-Vessel composting reactor, a vertical type and a horizontal type.

Figure 6-19 (overleaf) shows an example of vertical type In-Vessel composting reactor.

A mixture of dewatered sludge cake and bulking agent is fed into a silo, tunnel, channel, or vessel. Augers, conveyors, rams, or other devices are used to aerate, mix and move the product through the vessel to the discharge point. Air is generally blown into the mixture. After the first phase composting i.e., active composting, the finished product is usually stored in a pile for the second phase composting i.e., curing prior to distribution.



Source: USEPA, 1989

Figure 6.19 In-Vessel composting reactor - Taulman composting system

All the three composting methods require the use of bulking agents; wood chips, saw dust, and shredded tires are commonly used, but many other materials are suitable.

6.9.3 Applicability

The physical characteristics of most sewage sludge allow for their successful composting. However, many characteristics (including moisture content, volatile solids content, carbon content, nitrogen content, and bulk density) will impact design decisions for the composting method. Both digested and raw solids can be composted, but some degree of digestion (or similar stabilization) is desirable to reduce the potential for generation of foul odours from the composting operation. This is particularly important for aerated static pile and windrow operations.

Carbon and nitrogen content of the sewage sludge must be balanced against that of the bulking agent to achieve a suitable carbon to nitrogen ratio of between 25 and 35 parts carbon to one part nitrogen.

Site characteristics make composting more suitable for some sewage treatment plants than others. An adequate buffer zone from neighbouring residents is desirable to reduce the potential for nuisance complaints. In urban and suburban settings, in-vessel technology may be more suitable than other composting technologies because the in-vessel method allows for containment and treatment of air to remove odours before release.

The requirement for a relatively small amount of land also increases the applicability of in-vessel composting in these settings.

6.9.4 Advantages and Disadvantages

The advantages and disadvantages of sludge composting are as follows:

a. Advantages

- Sludge composting reduces landfill space of sludge by utilizing sewage compost as a soil conditioner or fertilizer.
- Sludge compost has market value and revenue is expected by selling it.
- Sludge compost is easy to store, handle and use.
- Addition of sludge compost to soil increases the soil's phosphorus, potassium, nitrogen and organic carbon content.

b. Disadvantages

- Odour is produced at the composting site.
- Pathogens possibly survive and exist in sludge compost.
- Sludge compost lacks consistency in product quality with reference to metals, stability, and maturity.

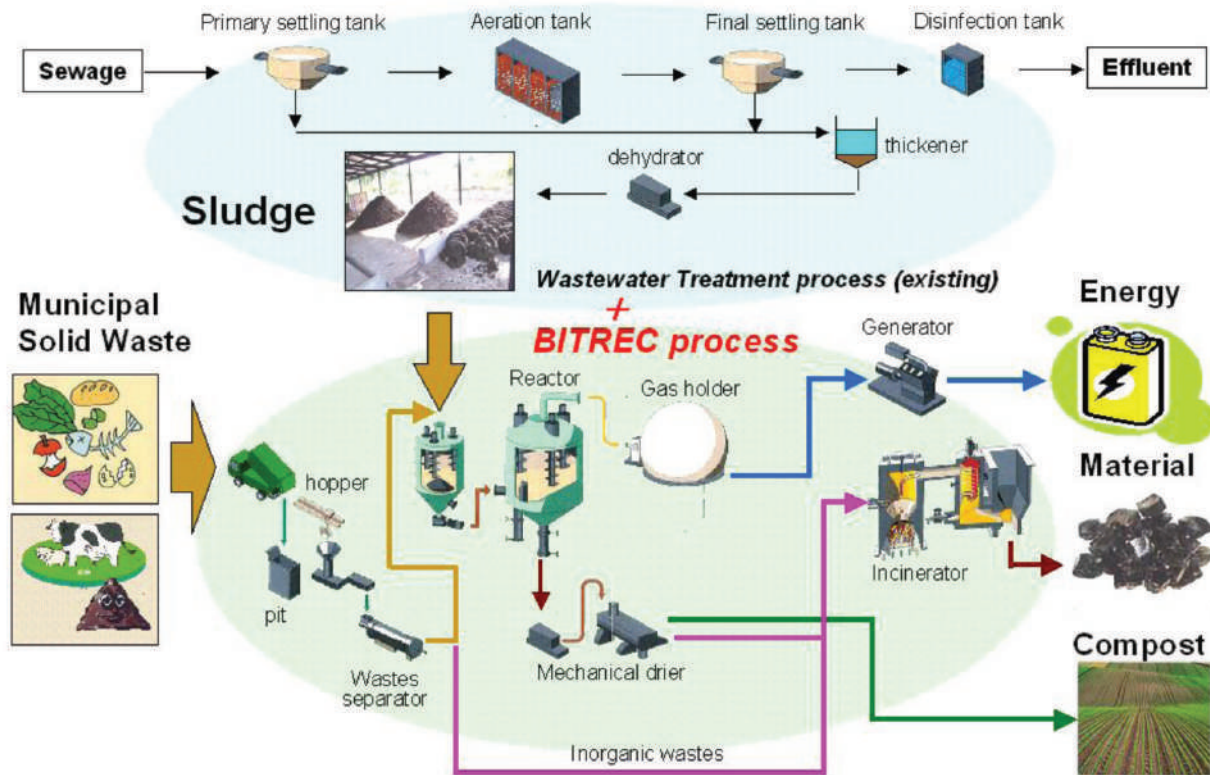
6.9.5 Design Considerations

The important matters related to design of sludge composting system are as follows:

- Sewage sludge characteristics such as moisture content, volatile solids content, carbon content, nitrogen content, and bulk density are to be considered when designing a composting system.
- It is essential for sludge composting to maintain uniform aerobic conditions during composting. Proper air supply procedures are required such as turning of piles or adequate aeration and selection of proper bulking agent is also necessary.
- Compaction of the composting mass should be avoided to maintain sufficient pore space for aeration.
- Bulking agent appropriate for sludge characteristics should be selected considering its characteristics such as size, cost/availability, recoverability, carbon availability, pre-processing requirements, porosity and moisture content.
- Metal content of the sewage sludge should be considered in the design to ensure a market for the final product.
- An odour control system should be considered especially for an in-vessel composting system.
- Composting detention time and temperature are determined considering the quality of product compost. For an aerated static pile or an in-vessel system, it should be kept at 55°C for at least 3 days and for windrow, 55°C for at least 15 days with 5 turns.

6.9.6 Mixed Composting of Sewage Sludge and Municipal Solid Waste

Dewatered sludge could be mixed with grounded organic municipal solid waste and could be used as a good soil conditioner (compost). However, this process needs proper policy guidelines, stringent regulations, standards and above all community awareness. Figure 6.20 shows a flow chart example of mixed composting of sewage and municipal solid waste.



Source: Ebara Engineering Service Co., Ltd. (there are many others also)

Figure 6.20 Mixed composting of sewage and municipal solid waste

6.10 SLUDGE DISPOSAL

6.10.1 Sludge Storage

6.10.1.1 General

Sludge storage facilities shall be provided at all mechanized STP. Appropriate storage facilities may consist of any combination of drying beds, separate tanks, additional volume in sludge stabilization units, pad areas or other means to store either liquid or dried sludge. The design shall provide for odour control in sludge storage tanks and sludge storage yard, covering, or other appropriate means.

6.10.1.2 Volume

Rational calculations justifying the number of days of storage to be provided shall be submitted and shall be based on the total sludge handling and disposal system.

Refer to Section 6.4 and 6.5 for anaerobic and aerobic digested sludge production values. Sludge production values for other stabilization processes should be justified on the basis of design. If the land application method of sludge disposal is the only means of disposal utilized at a STP, storage shall be provided based on considerations including at least the following items:

- 1) Inclement weather effects on access to the application land
- 2) Temperatures including frozen ground and stored sludge cake conditions
- 3) Haul road restrictions including spring thawing conditions
- 4) Area wise seasonal rainfall patterns
- 5) Cropping practices on available land
- 6) Potential for increased sludge volumes from industrial sources
- 7) Available area for expanding sludge storage
- 8) Appropriate pathogen reduction and vector attraction reduction requirements.

A minimum range of 120 to 180 days storage should be provided for the design life of the plant unless a different period is approved by the reviewing authority.

6.10.2 Disposal

Sludge is usually disposed of on land as manure to soil, or as a soil conditioner, or barged into sea. Burial is generally resorted to for small quantities of putrid sludge. The most common method is to utilize it as a fertilizer. Ash from incinerated sludge is used as a landfill. In some cases, wet sludge, raw or digested, as well as supernatant from digester can be constructed as lagoons as a temporary measure, but such practice may create problems like odour nuisance, groundwater pollution and other public health hazards. Wet or digested sludge can be used as sanitary landfill or for mechanized composting with city refuse. Disposal of sludge shall have to be as per the hazardous waste (handling and management) rules of MoEF if Table 6.14 and faecal coliform limits are violated.

6.10.2.1 Sludge as Soil Filler

The use of raw sludge as a soil filler directly on land for raising crops as a means of disposal is not desirable since it is fraught with health hazards. Application of sewage sludge to soils should take into consideration the following guiding principles:

1. Sludge from open air drying beds should not be used on soils where it is likely to come into direct contact with the vegetables and fruits.
- 2) Sludge from drying beds should be ploughed into the soil before raising crops. Top dressing of soil with sludge should be prohibited.
- 3) Dried sludge may be used for lawns and for growing deep rooted cash crops and fodder grass where direct contact with edible part is minimized.

- 4) Heat dried sludge is the safest from public health point of view. Though deficient in humus, it is convenient in handling and distribution. It should be used along with farmyard manure.
- 5) Liquid sludge either raw or digested is unsafe to use. It is unsatisfactory as fertilizer or soil conditions. If used, it must be thoroughly incorporated into the soil and land should be given rest, so that biological transformation of organic material takes place. It should be used in such a way as to avoid all possible direct human contact.

6.10.2.1.1 Heavy metal and Faecal coliform ceiling concentration in treated sewage sludge

The ceiling concentration of the heavy metals in the treated sewage sludge should not exceed the values mentioned in Table 6.14.

Table 6.14 Ceiling concentration of heavy metals in treated sewage sludge for use in agriculture

No.	Chemical	Ceiling concentration (A)	No.	Chemical	Ceiling concentration (A)
1	Arsenic	75	6	Chromium	500(total)
2	Cadmium	85	7	Selenium	100
3	Copper	4300	8	Zinc	7500
4	Mercury	57	9	Molybdenum	75
5	Nickel	420	10	Lead	840

(A)-Expressed as mg/kg on dry weight basis

If the concentrations in the treated sewage sludge exceed the values as in Table 6.14 land application shall not be permitted and the sludge shall have to be disposed or contained as per the hazardous waste (handling and management) rules of MoEF. In addition to the above heavy metal limits, the faecal coliform limit for sewage sludge shall be as under.

At least seven sewage sludge samples should be collected at the time of use or disposed and analyzed for faecal coliforms during each monitoring period. The geometric mean of the densities of these samples will be calculated and should meet the following criteria.

Less than 20,00,000 most probable number per gram of total dry solids (20,00,000 MPN / gTS)

Or

Less than 20,00,000 colony forming units per gram of total dry solids (20,00,000 CFU / gTS)

In general, digested sludge is indelicate, but definite value as a source of slowly available nitrogen and some phosphate.

It is comparable to farmyard manure except for its deficiency in potash.

It also contains essential elements to plant life and minor nutrients, in the form of trace metals.

The sludge humus also increases the water holding capacity of the soil and reduces soil erosion making it an excellent soil conditioner especially in arid regions by making available needed humus content which results in greater fertility.

6.10.2.2 Sludge Storage Yard

Dewatered cake typically is stored before additional treatment (e.g., heat drying) or being hauled off-site for use or disposal. Most flammable liquids would have been removed during dewatering and methane-generating microorganisms do not thrive in dry aerobic environments.

The amount of storage needed depends on the end use of the sludge cake. Often, biosolids will only be held for a few days or weeks before being treated further or hauled off-site. In this case, they are typically stored in large roll-off containers, 18 wheel dump trailers, concrete bunkers with push walls, or bins with augurs. However, if the biosolids will be applied on land or surface disposed, long-term storage may be required. In these cases, they often are stockpiled on concrete slabs or other impervious pads. When designing long-term storage facilities, it is needed to consider buffering, odour control, and accessibility. It is also needed to determine whether the storage facility should be open or covered.

Dried solids typically are stored either on-site or at a land-application site before disposal or beneficial use. They may be stored in stockpiles or silos. Because dried solids contain a significant amount of combustible organic material that can be released as dust, temperature control is important. If silos are used, it should be designed to promote cooling and maximize heat dissipation. Therefore, tall, narrow silos are better than wide ones. Narrow silos also make fires easier to control. However, if the silo is too narrow, it will make relief venting problematic. If multiple silos are used, there should be procedures to ensure that they are emptied cyclically to avoid exceeding safe residence times. Also, it is needed to consider the stored product's thermal stability in case a prolonged plant shutdown or if silo blockage occurs.

6.10.2.3 Sanitary Land Fill

When organic solids are placed in a landfill, decomposition may result in odour if sufficient cover is not available. Besides surface water contamination and leaching of sludge components to the groundwater must be considered. Decomposition may result in soil settlement resulting in surface water pond above the fill. Typical depths of soil cover over the fill area are 0.2m after each daily deposit and 0.6m over an area that has been filled completely.

Surface topography should be finished to allow rainfall to drain away and not allow it to infiltrate into the solid landfill. Land fill leachate requires long term monitoring and should satisfy the relevant water pollution control standards for land applications. Vegetation must be established quickly on completed areas to provide for erosion control. It is general practice not to crop the landfill area for a number of years after completion.

Land fills are not usually recommended for disposal of STP sludge. In case they are adopted, the above points should be considered.

6.10.2.4 Disposal in Water or Sea

This is not a common method of disposal because it is contingent on the availability of a large body of water adequate to permit dilution at some sea coast sites. The sludge, either raw or digested, may be barged to sea far enough to make available the required dilution and dispersion. The method requires careful consideration of all factors including flora and fauna for proper design and siting of outfall to prevent any coastal pollution or interference with navigation.

6.11 CORROSION PREVENTION AND CONTROL

6.11.1 Anaerobic Sludge Digesters

In sludge digestion tank, digestion of sludge is carried out under anaerobic conditions for a long period. During the normal functioning of the digester, and more so, during faulty operations, various acids are produced for a temporary period. The waste may contain appreciable quantity of sulphates due to seepage of sea water in coastal regions or due to industrial wastes. Under anaerobic conditions in digester the sulphate will be converted to hydrogen sulphide. The corrosion due to hydrogen sulphide is in fact due to sulphuric acid formed in the presence of moisture. This will attack the digester walls and also the mechanical equipment to such an extent that breakdown may occur ultimately. Cement that is resistant against H_2S , such as blast furnace slag cement, should be used in the construction of digesters.

It is observed that the draft tubes inside the digester are sometimes provided of mild steel. This is not a good practice, since the life of such metallic tubes in the highly corrosive interior will be very limited. Hume or concrete pipes of thicker cross section are therefore, recommended for use as draft tubes. Use of guy ropes inside the digesters should also be discouraged. Screw pumps are provided in the digester for proper circulation of the tank contents. The blades of this screw pump should be of corrosion resistant materials. In many installations the sludge gas is collected and burnt or utilized for other purposes. If the gas contains H_2S , this will be very corrosive under moist conditions to the gas engines, gas meters and all the equipment and piping. It is therefore, necessary to remove H_2S by scrubbing in such cases.

6.11.2 Sludge Pumps

For pumps and pumping equipment, proper material selection is of paramount importance. The pump casing is normally of close grained cast iron capable of resisting erosion on account of abrasive material in the waste.

For handling corrosive sludge, the impeller is generally made of high grade phosphor bronze or equivalent materials. The wearing rings for impeller should be of good corrosion resistant material such as bronze. The shafts are normally made of high tensile steel and replaceable shaft sleeves are recommended.

For pumps and pumping equipments, painting is the usual protective measure. Both the interior and exterior surfaces of pumps should be painted after rust scale and deposits are removed by sand blasting, wire brushing or rubbing with sand paper.

6.11.3 Piping Requirements in Treatment Plants

Piping in STP would be required in sewage and sludge conduits, drains and water lines to chemical process piping. Materials for various pipe line applications are mentioned in Table 5-27 of chapter 5 in Part A Manual.

6.11.4 Modification of Materials

Normally, the materials that are most suitable under the circumstances likely to be encountered should be used to be commensurate with economy. If justified economically, corrosion resistant construction material can be used initially. This may not require any additional protective coating frequently. Stainless steel, aluminium and plastics are examples of materials of this nature. It is possible that the use of such corrosion-resistant materials would be cost-effective in the long run. However, in STP, it is found that it is usually less expensive to use ordinary structural steel to which protective coatings are applied.

6.12 UPGRADING AND RETROFITTING OF SLUDGE FACILITIES

Over a passage of time, systems need to be upgraded and retrofitted. Keeping this in view, plants which have (a) SDB can implement mechanical dewatering methods, (b) gravity thickening can implement mechanical thickening. The area occupied by the SDB are needed for reconstruction and rehabilitation of sludge facilities and hence, in places of land shortage, SDB can be demolished and mechanical dewatering be adopted in those areas. However, as a matter of providing standby SDB for about 15 % requirement should be provided so that they can be used in case of any accidental breakdown of mechanical sludge dewatering equipment, but the width of the SDB shall be restricted to 3 m to enable its covering if required during times such as monsoons, etc.

The reconstruction of the sludge treatment facility should take each of following into consideration.

1) Study of basic policy

When reconstructing a sludge treatment facility, after studying the basic policy synthetically from the following viewpoint, it is necessary to determine details such as (a) Independent treatment or intensive treatment, (b) Simple reconstruction or improvement in functional use (addition, change, etc. of sludge treatment process), (c) Package of handling process, or reconstruction in each process and series unit, (d) Treatment of return flow from sludge treatment facility, (e) The future amount of sludge treatment, (f) The effective use (final disposal) method, (g) Energy saving, (h) Degree of aging, (i) Earthquake-proof, (j) Degradation of function, (k) Ease with maintenance and (l) Environment

2) Confirmation of space for reconstruction

In cases where space in the existing building and at site is adequate for the needs without being able to remove existing facilities, it can be constructed in the space. In cases where there is no space, removal and reconstruction is done for every series and process, or construction in another land is considered.

3) Intensity confirmation of existing building

In cases where it uses existing building, after taking the load of apparatus into consideration, intensity calculation of building is done. In cases where it extends [altering building and], seismic capacity evaluation and earthquake-proof construction may be needed.

4) Reconstruction procedure

In the following case, reconstruction procedures differ.

a) Independent treatment or intensive treatment

b) The whole sludge treatment process reconstruction, or each process and series unit

During construction period, reduction of the amount of sludge treatment and taking out the sludge to other facilities may be needed.

After considering the safety and economical efficiency, the reconstruction procedure is studied so that construction period can be shortened as much as possible.

5) The necessity for temporary facilities

In cases where it cannot perform reduction of the amount of sludge treatment, and another treatment, or in cases where safety, economical efficiency, and O & M are advantageous, sludge treatment by temporary facilities is carried out.

The necessity for temporary facilities of each process is based on the following as reference.

a) Thickening

Is taking out of sludge possible by vacuum vehicle etc. to other facilities or not?

b) Digestion

Is taking out of sludge possible to other facilities or not?

c) Dewatering

In cases where reconstruction is in a small scale and for a short period of time, can mobile dewatering system be used or not?

In addition, to installing temporary facilities, it needs careful adjustment of the amount of sludge treatment, operation stop time at the time of change, installation period of adjustment of facilities, etc.

6.12.1 Energy Saving Measures

The following is related to energy-saving technologies in sludge treatment process.

According to reconstruction stage, energy-saving equipment is introduced intentionally, and also it is desirable to save the energy of the whole system.

- 1) Thickening
 - a) Improvement in thickening performance
 - b) Improvement in solid recovery rate
 - c) Reduction of machine thickening power
- 2) Digestion tank
 - a) Management of injection sludge concentration to digestion tank
 - b) Temperature management of digestion tank
 - c) Strengthening of keeping warm of digestion tank
 - d) Low motorization of stirrer of digestion tank
 - e) Strengthening of heat insulation to steam piping (warming facilities)
 - f) Automatic control of boiler for warming and automatic control of hot water heater
- 3) Dewatering
 - a) Management of supply sludge concentration
 - b) Reduction in moisture content of dehydration sludge
 - c) Control of series of dehydrator also including conveyance facilities
 - d) Reduction of mechanical dehydration power

6.13 BIOMETHANATION AND ENERGY RECOVERY (CARBON CREDIT)

6.13.1 General

Sewage sludge includes organic matter made of carbon, hydrogen, sulphur, and so on, and is a potential energy source of high value. Energy utilization methods include the method of recovering digester gas as energy and using it as heating fuel or in power generation, and the method of using it as fuel after drying. The water content in sludge has a major effect on energy consumption and energy recovery aspects with regard to utilization of sludge as energy. Therefore, water content should be reduced as far as possible starting from the sludge thickening stage to the dewatering and incineration stages. It is important to improve the overall energy utilization rate. Overall energy utilization of sludge has just made a beginning. Henceforth, the energy self-sufficiency of STP will need to be enhanced and stability in operation of STPs will need to be ensured over the long term. Moreover, these energy uses need to be promoted so as to contribute to the protection of the global environment. Utilization of digester gas, dried sludge and carbonized sludge is described hereafter.

6.13.2 Digester Gas Utilization

The utilization of digester gas from an operating STP at Nesapakkam in Chennai is presented in Section 5.16.1.2, Table 5-28. Generally, digester gas is used as fuel in boilers for heating sludge digestion tanks; surplus gas is incinerated in biogas combustion units and discharged to the atmosphere. When surplus gas exists in large amounts, the energy possessed by the gas can be effectively utilized and energy savings can be achieved in the entire system.

When considering the effective utilization of this unused energy, if there is a demand for heat for direct use such as auxiliary fuel for incinerating sludge, fuel for boiler (for hot water supply, for cooling and heating), a simple and highly efficient system is preferable. In recent years, power generating equipments using heat engines including gas engines have been on the rise. Moreover, there are practical instances of heat recovered from exhaust gas as well as cooling water in addition to power generation from gas engines. However, as the system becomes complex, studies from the viewpoint of construction cost and O & M are necessary. When digester gas obtained from anaerobic fermentation of sewage sludge is to be used for power generation, siloxane included in minute quantities in the digester gas sticks to the internal surface of cylinders and gas engine plugs causing accidents due to misfiring and abnormal ignition; therefore, measures against siloxane need to be adopted. Silicone, which is the source from which siloxane is generated, is included in major proportion in shampoo and rinse, used in the bathroom.

For this reason, siloxane have often been found in sewage in recent years. Siloxane gets volatilized at room temperature. If the temperature is higher, larger amount of siloxane gets volatilized. A large amount of siloxane moves to the digester gas in the digestion tank during heating, and its concentration becomes 10-100 mg/Nm³ approximately. Research on this feature has been carried out in recent years. It has been verified that the major part of siloxane can be removed by activated carbon adsorption and high pressure water absorption.

Other policies for effective energy utilization are fuel cells, microgas turbine power generation, and automotive fuel gas applications, which have been practically realized. The features of fuel cell are its high efficiency and no rotating parts. Thus, there is no noise, O & M are easy and exhaust is also clean. Although it is necessary to study the effects of construction cost, life of fuel cells, sulphur included in digester gas, effective utilization of digester gas may be anticipated in the future. Figure 6.21 is an example of flow of power generated from digester gas (gas engine).

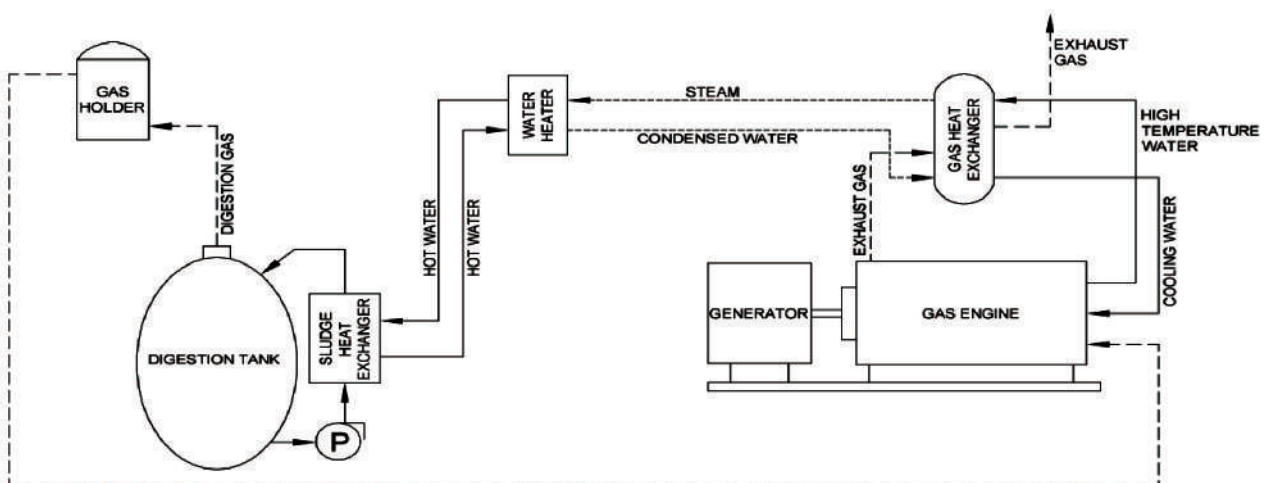


Figure 6.21 Example of flow of power generated from digester gas

It is important to study thoroughly the construction cost, quantity of digester gas generated outside of O & M cost, quantity of gas required for heating digester tank, quantity of surplus gas, and the temporal and seasonal variations of these and to confirm whether operation can be carried out at a high operating rate and at high efficiency.

6.13.3 Utilization of Dried Sludge

The utilization of dried sludge is mentioned in Section 6.14.2.

6.14 RECENT TECHNOLOGIES IN SLUDGE TREATMENT

6.14.1 Necessity of Sludge Treatment

With the progress of sewerage systems in urban areas, the amount of sewage volume increases and the amount of sludge generated during sewage treatment also increases naturally. Sewage treatment necessarily generates sludge and the bottom line of sewage treatment is effective, stable and lasting sludge treatment.

At present, in India, sludge is treated mainly by drying in sludge drying beds and dried sludge is utilized as soil filler. However, the increase in sludge volume, progress in urbanization and rise in the environmental awareness of people, etc., call for the adoption of new technologies such as mechanical dewatering, incineration, melting, etc., which are technologies for treating sludge more efficiently and reducing the sludge volume. The sludge volume is reduced gradually in each step of sludge treatment process. The sludge volume reductions in case of each step are roughly estimated as under in Figure 6.22.

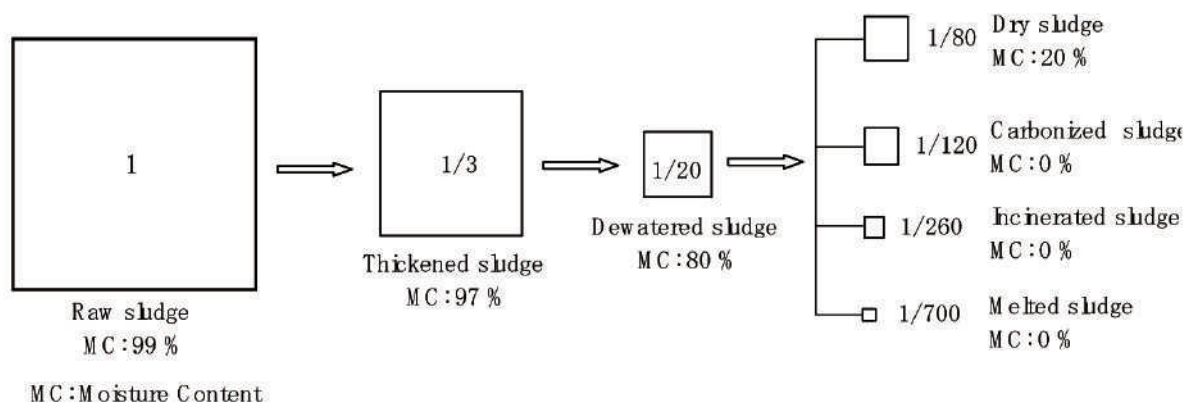


Figure 6.22 Sludge volume reduction of each step of sludge treatment process

On the other hand, sewage sludge is a useful resource, which consists of organic matter that can be used as fertilizer and inorganic substances like a soil-sludge that is used as immobilized bricks. Dry solids of sewage sludge also have calorific value near to coal. Therefore, it is desirable to use the sludge effectively as green farmland soil filler, construction materials, energy sources, etc. Proper utilization of sludge enables reduction of the quantity of sludge to be disposed off. Furthermore, adoption of measures against global warming is an important topic. Since sewage sludge is one of the typical biomass with carbon neutral character, its utilization is likely to contribute to reduction of greenhouse gas. This section describes new sludge treatment technologies based on the above viewpoints.

6.14.2 Types of Sludge Treatment Technologies

The new sludge treatment technologies are summarised in Table 6.15 overleaf.

Table 6.15 Types of sludge treatment technologies

Process	Objectives	Description
Soil sludge immobilization	Utilisation as material for immobilized blocks	This implies a well dried sludge which is non-volatile and mixing with controlled amount of clay and clinker or fly ash or cement and burning like bricks. These are suitable only for chemical precipitated sludge and which are fully dried and volatilized before use. The immobilized blocks are used as paver blocks in walkways or compound walls where these are only panel fillers and not load bearing.
Sludge Drying	Utilisation as Soil filler, Fuel	Sludge drying system is one of several methods that can be used to reduce the moisture content and volume and improve the quality of sewage sludge. Dried sludge is usually used as soil conditioner and soil filler, and is recently being used as fuel. These are also used as pre-treatment in sludge incineration, melting and carbonization.

6.14.3 Heat Drying

6.14.3.1 Description

Sludge drying methods include heat drying and solar drying. Heat drying systems are described in this section. Heat drying system is one of several methods that can be used to reduce the moisture content and volume and improve the quality of sewage sludge. Dried sludge is usually used as soil conditioner and fertilizer and is recently being used as fuel. Heat drying systems are also used as pre-treatment for sludge incineration, melting and carbonization. Heat drying systems are divided broadly into direct drying and indirect drying, according to the heating method. The two systems differ in the process flow and drying characteristics. In order to select a drying system, it is necessary to consider the desirable moisture content of dried sludge. The technology is to spread on concrete platforms on a side open with roofed sludge shed and blow hot air over the width by a moving facility with arm extending to full width and with downward air diffusers and the to and fro movement controlled by trip switches. The air heater is integral to the pipeline and the cable alone travels to and fro. The quantity of air, heat and the rate of travel are tapered as the heating progresses. Cross ventilation of the shed and surrounding farm forestry in two layers are needed.

6.14.3.2 Advantages and Disadvantages

The advantages and disadvantages of this process are as follows:

a. Advantages

- It produces a sludge that can be easily transported to point of use without spillages.

b. Disadvantages

- Requires careful on-site adjustments to prevent dried sludge from being blown up and stopping the drying when the moisture content reaches about 25%.
- High O&M cost due to power requirement for heat generation.

6.14.3.3 Design Considerations

These are situation specific and the only guideline is to apply sludge in not less than 20 cm layers and not over 30 cm layers. To start with, and include a tiller in the hot air arm that can be used once in a while by manipulating the control as a level arm and a length of pipelines over the bed not exceeding 3 m.

6.14.3.4 Applicability

Heat drying is an effective sewage sludge management option for many facilities that need to reduce sewage sludge volume while also producing an end product that can be beneficially reused.

Heat drying is applicable to urban settings because it requires a relatively small amount of land and facility design allows process air to be captured for treatment. These are not yet applicable in India. When India has a huge agrarian base it is not correct to destroy the biological sludge which is a good soil filler.

6.14.4 Solar Drying

6.14.4.1 Description

The main reason for drying the sludge is the high cost of sludge disposal. Hence, every ton of water extracted from the sludge lowers the disposal cost for the STPs. Drying of the filter cake through thermal means, is one of the technically viable schemes. However, the energy requirement of the thermal drying process makes the operating cost prohibitively high.

Since solar radiation is the cheapest form of thermal energy, solar drying is a techno economic solution for sludge drying.

6.14.4.2 Main Components of Solar Sludge Drying System

The main components of a solar sludge drying system are as follows:

a. Sludge Drying Hall

This is like a Greenhouse, trapping solar radiation and ensures that the rain is kept out.

b. "TURNING" machine

The solar radiation warms the sludge's surface. The rise in the temperature forces the water molecules out into the surrounding air. The moist air transports the water and has to be evacuated. However, while the surface dries the lower parts remain moist and have to be turned. This is achieved by a machine, which turns and also conveys the sludge across the floor of the drying hall. This also eliminates anaerobic areas that generate bad odour during sludge drying.

c. Control Panel

A PLC based control panel to ensure that the sludge drying process is monitored and controlled so that sufficient dryness is achieved in the final product.

d. Instruments

Various instruments to monitor parameters like Temperature, Humidity, Wind, Rain, etc., are provided to monitor the drying process.

The schematic of the process and infrastructure are shown in Figure 6.23 and Figure 6.24.

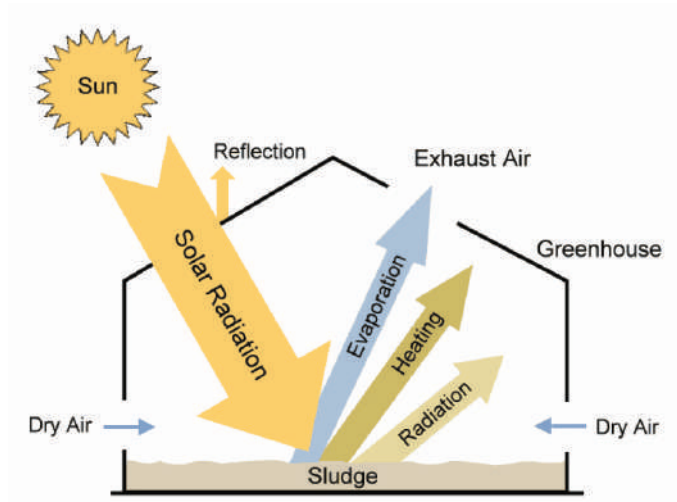
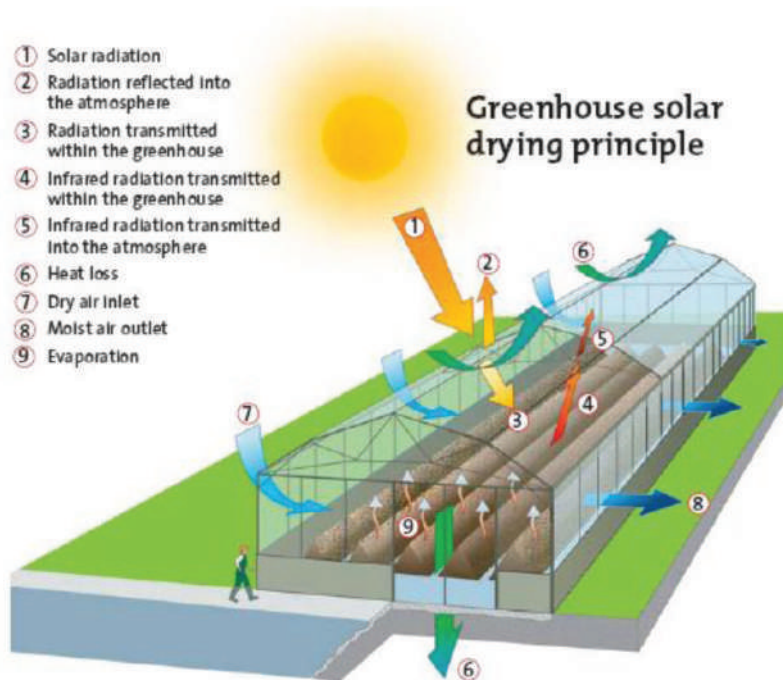


Figure 6.23 Typical operations in solar sludge drying



Source: <http://www.veoliawaterst.com/solia/en/>

Figure 6.24 Typical solar sludge drying

6.14.4.3 Advantages and Disadvantages

a. Advantages

- The cost of disposal is reduced by 75% to 80% as the solids content in the sludge is increased from 20% to 80% during drying.
- The process produces easy to handle bulk pellets from the sludge.
- Uses solar heat for the drying process instead of electricity thereby reducing the operating cost.
- The covered sludge drying area ensures continuous operation throughout the year, even during the rainy season.
- This ensures complete aeration and turning of the sludge in the entire sludge drying area.
- Eliminates anaerobic areas that generate bad odour during sludge drying
- Completely automatic process, without any human intervention during the drying process.

b. Disadvantages

- Proper precaution has to be ensured so as to ensure no fire hazard takes place in the solar sludge drying bed.

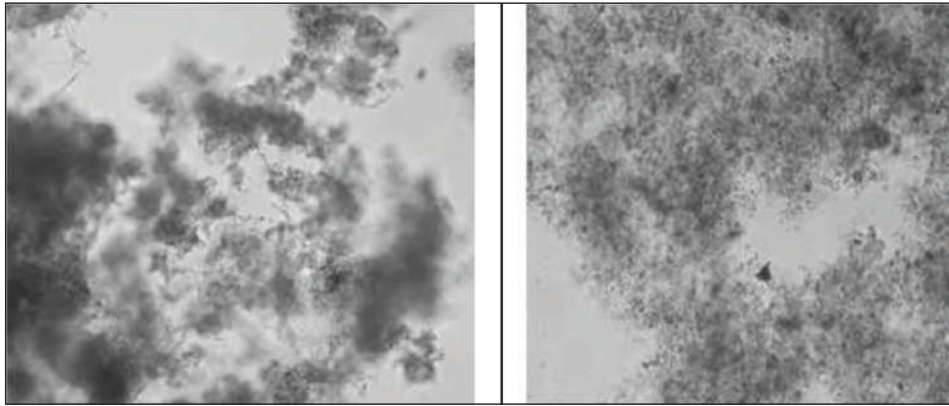
6.14.4.4 Potential Uses for Dried Sludge

- The dried sludge can be used as manure/soil conditioners.
- The dried sludge pellets can also be used as a fuel source in coal fired power plants and in cement kilns.

6.15 ULTRASONIC DISINTEGRATION OF FEED SLUDGE TO DIGESTER

A technology to disintegrate the sludge biosolids by using ultrasonic frequency (sonication) before feeding to anaerobic sludge digesters has been engaging the interest of a few research studies. A research study from Gdansk University of Technology, Poland and Vilnius Gediminas Technical University, Lithuania reported that the disintegration is stated to result in a more dispersed and homogenous flocs of activated sludge as in Figure 6.25 (overleaf) and intensified the biogas production and improved the quality of digested sludge.

The experiment is stated to have been carried out in laboratory scale digester using two reactors of each 15 days hydraulic retention time under mesophilic conditions. The results are reported to have showed a 20% increase of biogas and 10% increase of methane as compared to that from the digester fed with sludge biosolids without the ultrasonic disintegration. The authors concluded that due to sludge disintegration, the organic compounds were transferred from the sludge solids into the aqueous phase resulting in an enhanced biodegradability.



Source: Renata Tomczak-Wandzel. et. al., 2011

Figure 6.25. Activated Sludge before (left) and after (right) Ultrasonic Disintegration

The experiment demonstrated that this technology has the advantages of increase of sludge digestion efficiency, increase of about 20% of the volume of biogas produced, increase of about 10% of the methane content in biogas and reduction of the volume of residual sludge by 12%.

In another study by the Centre for Advanced Water Technology and the Public Utilities Board of Singapore, the ultrasound disintegration technology is stated as potentially useful to disintegrate feed sludge solids and enhance anaerobic digestion and gas yield. Two full scale digesters of 5000 cum capacity, each are reported as tested simultaneously in Singapore one with and the other without ultrasonic disintegration of feed sludge. It is reported that in comparison with the control, i.e., without sonication, the five-month field study showed that ultrasound pre-treatment of the sludge increased the daily biogas production up to 45% and there were no significant differences in biogas composition from the two digesters. It is inferred that an increase in sludge solids removal of up to 30% is expected under optimal operation conditions. (Source Rongjing Xie, et.al., 2007).

These technologies appears to hold promise towards energy savings and reduction in volumes of anaerobic digesters for sewage treatment.

6.16 GUIDING PRINCIPLES OF SLUDGE TREATMENT TECHNOLOGIES

Every effort should be made to go eco-friendly in dealing with biological sludge from STPs. They need to be dried to about 20% moisture and then integrated with the agriculture and farm forestry. If needed to be applied on sensitive lawns, Gamma ray irradiation of the sludge is mandatory before such application. The advancement in anaerobic sludge digestion in the coming years may address these processes, whereby the raw sludge will be preheated from 60°C to 80°C for pasteurization and mixed with recycled hot digester gas.

If needed, it will be supplemented with steam thus, bringing about biological hydrolysis, which can generate more renewable energy than conventional thermal hydrolysis as in the present day digesters.