

Mason's Training Programme on Onsite Treatment Systems: Evaluation

November 18, 2016

TECHNICAL SUPPORT UNIT:

iihs TM
INDIAN INSTITUTE FOR
HUMAN SETTLEMENTS

IN ASSOCIATION WITH:



 **Keystone**

 Consortium for
DEWATS
Dissemination
Society

1. Which among the following is the correct dimension of a pit for 5 users? (1 point)

a. Diameter: 3.3 feet, Depth: 4.3 feet

b. Diameter: 6 feet, Depth: 7feet

Answer:

_____]

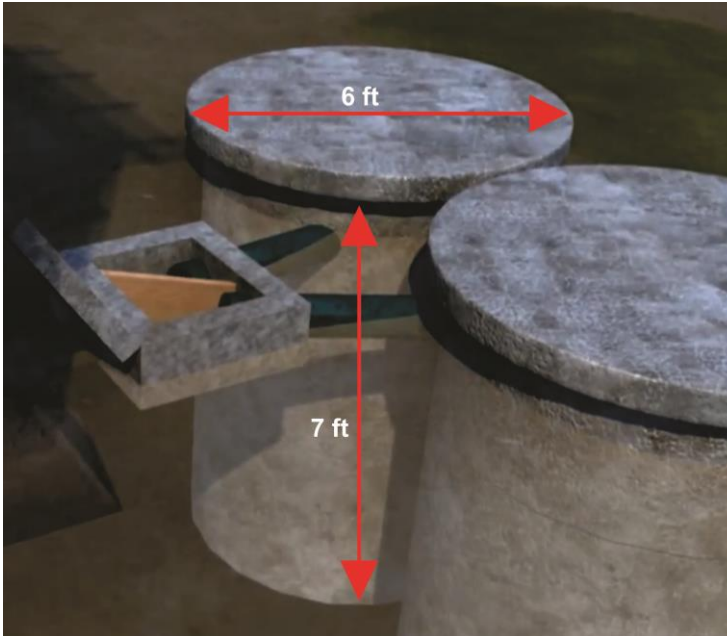

2. Which of the following can be used in an inspection chamber to divert the faecal matter? (1 point)

a. Wooden Plank

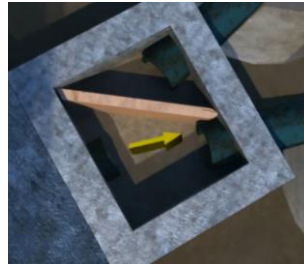

b. Gunny Bag



3. What is the usual diameter of a drain pipe used in a twin pit? (1 point)

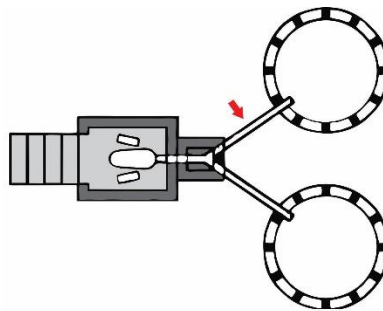

Answer: _____

4. Name the components a, b & c?

(3 points)



Answers: a. _____, b. _____
c. _____

5. Is it required to raise the height of septic tank or a pit above the ground level to prevent rain water entering into the chamber? (1 point)

a. Yes, b. No

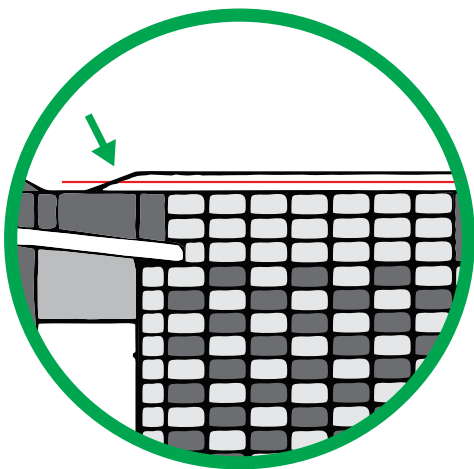

Answer: _____

6. What should be the minimum distance between two pits in a twin pit system?

(1 point)



a. 1 meter, b. 0.5 meters

Answer: _____

7. What should be the minimum distance between the twin pit and a shallow tube well?

(1 point)

a. 5 feet, b. 10 feet

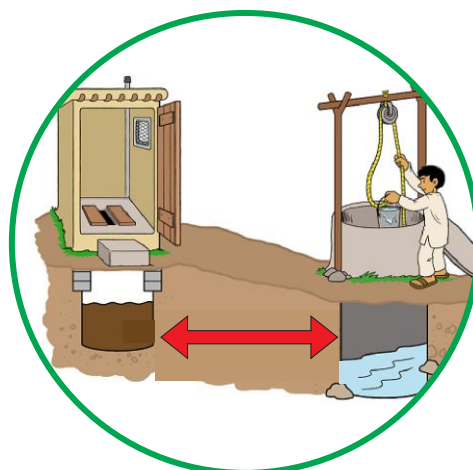

Answer: _____

8. In a Twin pit toilet, can both the pits be used simultaneously to increase storage capacity? Select the correct picture (1 point)

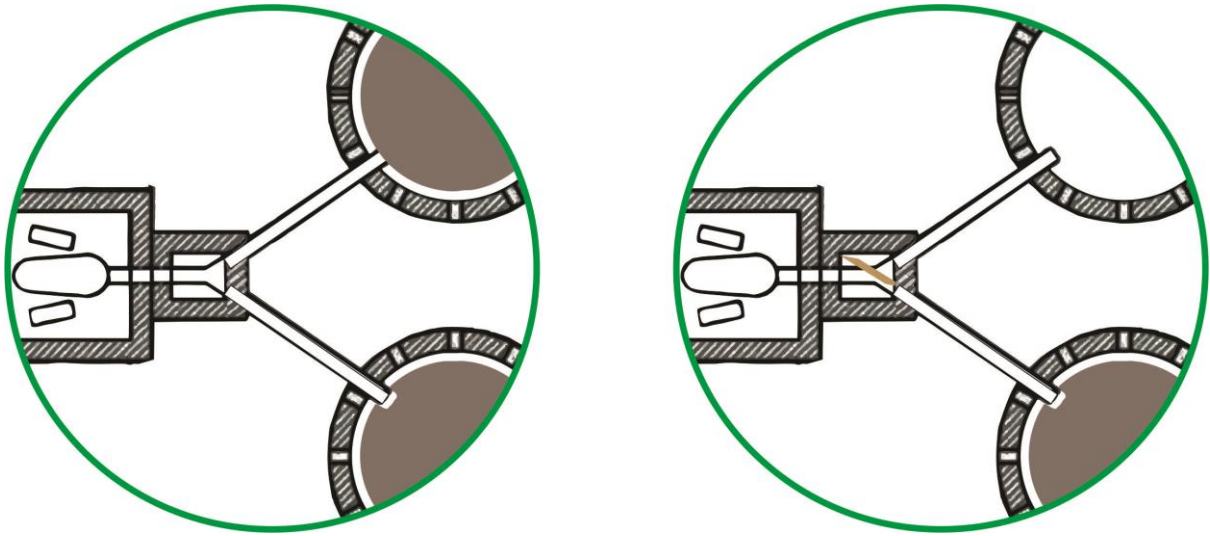

Answer: _____

9. A septic tank outlet should be connected to? (1 point)



a. Open Nala,

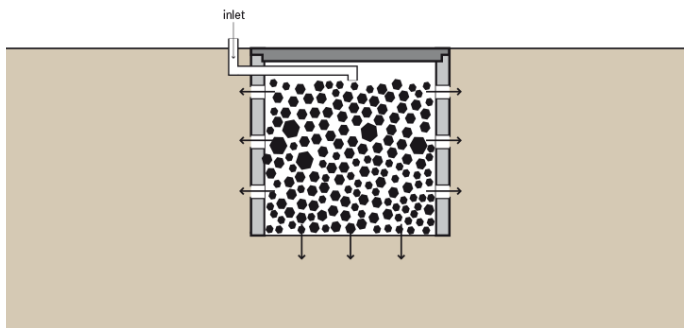

b. Soak Pit



c. Canal/River

Answer: _____

10. Which out of the following is appropriate size for a septic tank for 5 users?

(3 points)

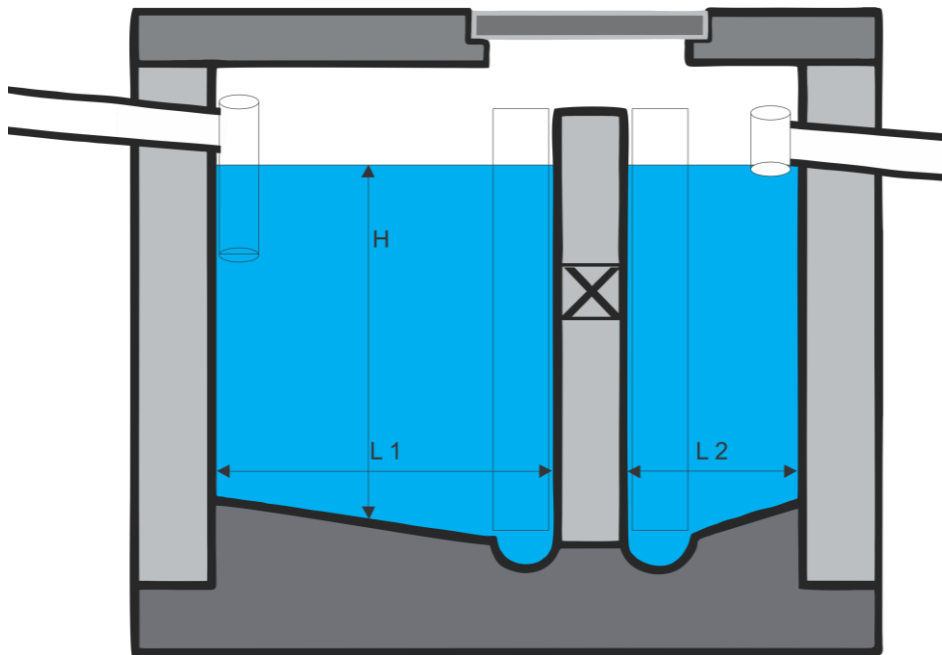

a. h: 3.3 feet, l_1 : 3.3 feet, l_2 : 1.5 feet, **b.** h: 6.5 feet, l_1 : 13 feet, l_2 : 6.5 feet

Answer: _____

11. To increase the life of the septic tank, holes or perforations can be provided in the bottom (1 point)

a. Correct, b. Wrong

Answer: _____

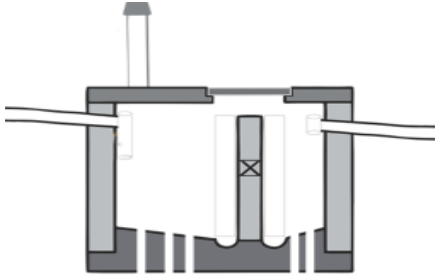

12. Name the components of the septic tank? (2 points)

(2 points)

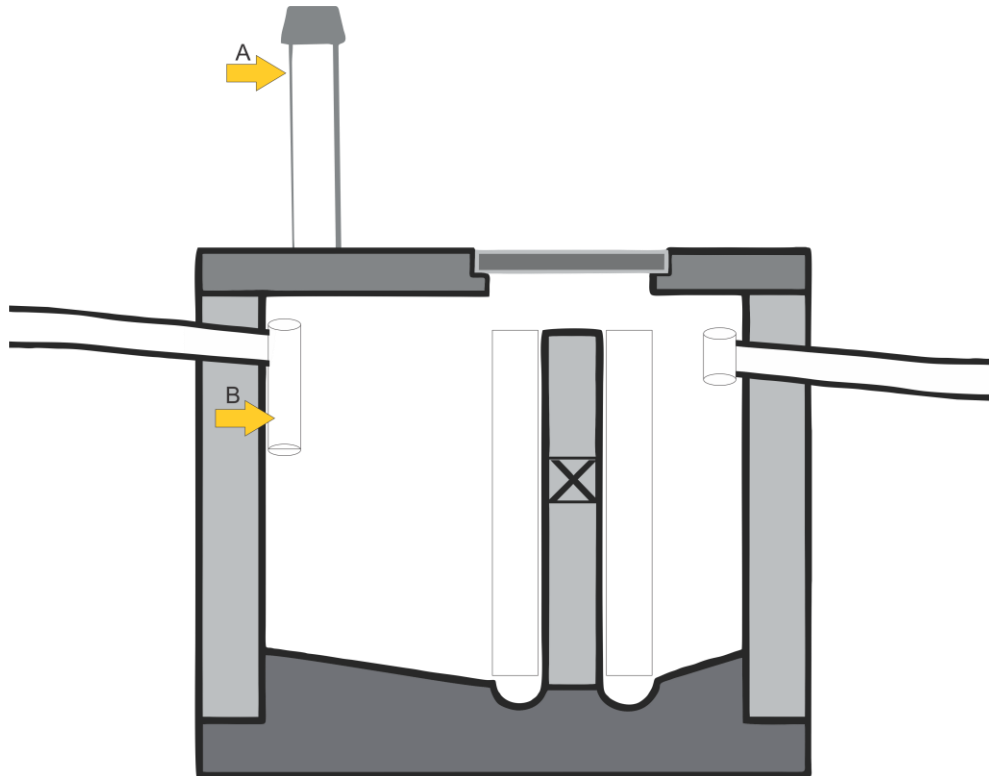

Answers: a. _____, b. _____

13. Match the following:

(4 points)

| | | | |
|---|--------------------|---|----------------|
| A | Septic Tank | 1 | Y-Junction |
| B | Twin Pit | 2 | Wooden Plank |
| C | Soak Pit | 3 | Partition Wall |
| D | Inspection Chamber | 4 | Brick Bats |

Answers: a. _____, b. _____

c. _____, d. _____