

ACKNOWLEDGEMENTS

I would like to thank the following individuals for their help during the course of this thesis: Dr Santiago Septien, Dr Jonathan Pocock and Kerry Lee Philp. Most importantly my friend Chiedza Francesca Munyeza for her continuous encouragement. To Blessing Makununika my partner in confusion, this has been a chapter. Lastly I thank myself for gathering enough motivation and energy to complete this dissertation.

ABSTRACT

Source separation of urine from domestic waste water provides a sustainable way of managing nutrient and water recovery from urine. This study was performed in the context of the Bill & Melinda Gates (BMFG) foundation's Reinvent the Toilet Challenge (RTTC) which underscores the provision of low cost and sustainable sanitation solutions to poor communities. This study investigated the feasibility of applying a forward osmosis (FO) dewatering process for nutrient recovery from source separated urine under different conditions using ammonium bicarbonate as a draw solution. The diluted draw solution can be separated by moderate heating up to 60 °C using low grade heat, allowing ammonia and carbon dioxide to escape as gases from the diluted draw solution. The ease of separation from the permeate made ammonium bicarbonate the draw solution of choice. The forward osmosis process exhibited fairly high water fluxes of up to 6 L/m².h when operated in the active layer facing feed solution (AL-FS) mode using thin film composite membrane (TFC). However, the active layer facing draw solution (AL-DS) mode had almost twice the water flux and solute flux obtained in the (AL-FS). The process also reviewed higher rejections for total nitrogen, chlorides and total phosphates and rejections for sodium and potassium were the lowest. A forward osmosis mass balance framework developed in this work as a basis for modelling was in good agreement with the experimental water flux and nutrient rejection values. Approximately 4 g of ammonium bicarbonate back diffused into the feed solution for every litre of water that permeated the membrane from the feed side towards the draw solution. Membrane fouling induced a 12 % drop in flux. Circulation of deionized water and osmotic backwashing recovered 95 % and 98 % of the fresh membrane water flux respectively.



**UNIVERSITY OF
KWAZULU-NATAL**

**INYUVESI
YAKWAZULU-NATALI**

Forward osmosis of stored urine

Albert Muzhingi

BSc Eng. (UKZN)

Student number: 210546284

This thesis is submitted in fulfilment of the requirements of Masters of Science degree in Engineering, in the School of Chemical Engineering at the University of KwaZulu Natal, South Africa

Supervisor: Prof. Chris Buckley

Co-supervisor: Dr. Jon Pocock

Co-supervisor: Dr. S Septien

DECEMBER 2016

EXAMINER'S COPY

CONTENTS

1	INTRODUCTION.....	1
1.1	Aim and Scope.....	5
1.2	Objectives	5
1.3	Outline of the dissertation.....	5
2	LITERATURE REVIEW.....	6
2.1	Human urine generation.....	6
2.1.1	Urea Hydrolysis	6
2.1.2	Existing technologies for urine treatment.....	7
2.2	Generalities of forward osmosis (FO).....	10
2.2.1	Introduction to membrane separation.....	10
2.2.2	Definition of forward osmosis	12
2.2.3	Calculation of osmotic pressure	13
2.2.4	Draw solution.....	14
2.2.5	Forward osmosis membranes.....	17
2.2.6	FO membrane modules	18
2.2.7	Forward Osmosis Applications	20
2.3	Factors Influencing forward osmosis	21
2.3.1	Concentration Polarisation.....	21
2.3.2	Membrane Fouling.....	22
2.3.3	Reverse draw solute diffusion.....	25
2.3.4	Effect of solution temperature and draw solution concentration on water flux	25
2.3.5	Species rejection	26
2.4	Investigations on the use of FO for urine treatment.....	26
2.5	Summary	27
3	MATERIALS AND METHODS	30
3.1	Feedstock and Draw Solution	30
3.2	Forward osmosis setup.....	30

3.3	FO Membrane	33
3.4	Analytical Equipment	34
3.4.1	Conductivity and pH measurements	34
3.5	Sampling	35
3.6	Chemical Analysis	35
3.6.1	Microwave-Plasma Atomic Emission Spectroscopy (MP -AES)	35
3.6.2	Chloride Analyzer 926	35
3.6.3	Spectroquant pharo 300	36
3.6.4	Chemical Oxygen Demand (COD)	36
3.6.5	Osmotic pressure	36
3.7	Baseline determination	37
3.8	Determination of the parameters of the FO process	37
3.8.1	Determination of water flux and batch recovery	37
3.8.2	Reverse salt permeation	38
3.8.3	Solute flux	38
3.8.4	Rejection	39
3.8.5	Osmotic pressure calculation	40
3.9	Membrane fouling evaluation	41
3.9.1	Osmotic backwash	41
3.9.2	Scanning Electron Microscopy (SEM) Observations	42
4	RESULTS AND DISCUSSION	43
4.1	Analysis of the feedstock	45
4.2	Flux analysis	46
4.2.1	Effect of membrane orientation on water flux and reverse solute flux	46
4.2.2	Evolution of flux with time	46
4.2.3	Water Recoveries	49
4.2.4	Relationship between draw solution concentration and water flux	49
4.2.5	Relationship between water flux and osmotic pressure	51
4.3	Rejections	52

4.4	Fouling	55
4.4.1	Baseline study	55
4.4.2	Osmotic Backwash.....	57
4.4.3	SEM and EDX Analysis	58
4.5	A mass balance forward osmosis framework.....	61
5	CONCLUSIONS and RECOMMENDATIONS	65
6	PERSPECTIVE.....	67
6.1	Use of low grade heat from faecal sludge to recover the draw solution-interpolating literature data 67	
6.2	Conceptual process flow diagram for reconstituting FO draw solutes.	68
7	REFERENCES.....	70
	APPENDIX A: STANDARD OPERATING PROCEDURE	78
	• Standard Operation Procedure – Osmolality.....	81
	• Standard Operation Procedure – Microwave Plasma Atomic Emission Spectrometer ...	84
	• Standard Operation Procedure – Phosphate and total P Analysis.....	89
	• Standard Operation Procedure – Nitrogen (Total) Cell Test	93
	• Standard Operation Procedure – Chloride Analysis	95
	• Standard Operation Procedure – Total Alkalinity	97
	• Standard Operation Procedure –Solids - 2540.....	99
	APPENDIX B- RAW DATA	106
	APPENDIX C: EXPERIMENTAL RESULTS.....	113
	APPENDIX D: DERIVATION OF THE MASS BALANCE EQUATION.....	117

LIST OF FIGURES

Figure 1-1: Flowchart indicating various processes that can be adopted in processing excreta (PRG Internal discussion document,2016)	3
Figure 2-1:Schematic diagrams of the Forward Osmosis Process illustrating the direction and magnitude of water flux in FO, and RO	13
Figure 2-2:Osmotic pressure as a function of solution concentration at 25 °C for various draw solutions (Cath et al., 2006)	15
Figure 2-3:Flow pattern in a plate-and-frame module(orange :feed; red: retentate; yellow: permeate)http://www.alfalaval.com/products/separation/membranes/Modules/#sthash.ncHtPyyT.dpuf (Accessed on 01 November 2016)	18
Figure 2-4:Flow patterns in spiral wound modules (Mehta, 1982).....	19
Figure 2-5:Hollow fiber FO membranes grouped in bundles of differing size and potted at each end. (Nunes and Peinemann, 2001)	20
Figure 2-6:: Various applications of forward osmosis in the broad fields of power generation, waste water treatment and life science (Zhao et al., 2012)	21
Figure 2-7::(a) Concentrative internal concentration polarisation (ICP)	22
Figure 2-8:Membrane fouling mechanisms showing biofouling (R_a), pore blocking (R_{pb}), cake layer (R_c) and membrane resistance (R_m) (Wang et al., 2010).....	23
Figure 2-9:(a) Normal operation configuration (permeate flow from feed side to draw side) ;(b) Osmotic backwashing configuration (DI water flow from draw side to feed side) (Kim et al., 2012).	24
Figure 3-1: Photograph of the FO membrane cell depicting the surface on which the TFC-ES FO membrane sheet is placed. The flow channels of the SEPA cell are also visible on the photograph ...	31
Figure 3-2: Schematic diagram of the FO setup indicating the set –up of the various units of the FO rig	32
Figure 3-3: Photograph the FO laboratory rig showing the various components of the FO laboratory rig used in this study.....	33
Figure 3-4:Flat sheet TFC-ES membrane placed on the FO membrane cell	34
Figure 4-1: Water flux with time with stored urine as the feed solution and ammonium bicarbonate(1M,2M and 2.5) as the draw solution with the membrane operated in the AL-FS mode.	47
Figure 4-2: Water flux for urine feedstock at different dilution factors with 2 M ammonium bicarbonate as the draw solution with the membrane operated in the AL-FS mode. Each condition repeated three times with new membranes and solutions.....	48
Figure 4-3:Cumulative volume as a function of time at different draw solution concentrations (1 M,2 M and 2.5 M) with urine as the feed with the membrane operated in the AL-FS mode.....	49

Figure 4-4:Water flux as a function of draw solution concentration for short- term bench scale forward osmosis experiments with urine as the feed solution. Experiments were conducted with feed and draw solution temperatures of 22 ± 0.1 °C and feed and draw solution flow rate of 0.5 L/min	50
Figure 4-5:Water flux as function of the osmotic pressure difference between the feed and draw solution during an 8 h run with the membrane in the AL-FS mode and feed and draw solution flow rate 0.5 L/min and a temperature of 22 ± 0.1 °C.	51
Figure 4-6:Logarithm of the ratio of bulk draw solution osmotic pressure to bulk feed solution osmotic pressure against water flux.....	52
Figure 4-7:Water flux vs measured nutrient rejection during baseline testing with 21 g/L NaCl as the feed and 2 M ammonium bicarbonate as the draw solution. The membrane was operated in the AL-FS mode.....	53
Figure 4-8: Rejections versus water flux during experiments with stored urine as feed solution	54
Figure 4-9: Water flux versus time during FO experiments with 2 M ammonium bicarbonate as the draw solution with the membrane operated in the AL-FS mode.	55
Figure 4-10: Water flux as a function of time for the lab scale set up with deionised water as the feed solution and 2 M ammonium bicarbonate as the draw solution. The membrane was operated in AL-FS mode with the feed and draw solution temperature maintained at 22 ± 0.5 °C	56
Figure 4-11: Flux recovery during different wash cycles	57
Figure 4-12: Virgin membrane (a), fouled membrane after a FO run (b) and cleaned membrane after osmotic backwash (c).....	58
Figure 4-13: SEM –EDX analysis of the virgin membrane and fouled membranes.....	59
Figure 4-14: Urine compounds concentration in the feed solution during FO run	62
Figure 4-15: Urine compounds concentration in the draw solution during a FO run	63
Figure 4-16 shows the good fit between the experiential water flux and the predicted water flux.....	63
Figure 4-17: Experimental and calculated water flux as a function of time	63
Figure 7-1: Comparison of the osmotic pressure of NaCl obtained through the use of the Van` t Hoff equation, Pitzer correlation and Literature values at 25 °C	106
Figure 7-2:Error analysis between the values obtained through the use of the Van` t Hoff and Pitzer correlation as compared to those from literature.....	107
Figure 7-3: Comparison of the osmotic pressure values for ammonium bicarbonate obtained through the use of the Van` t Hoff equation and literature values.	107
Figure B- 1: NaCl concentration vs osmolality calibration curve.....	111
Figure B- 2:Ammonium bicarbonate concentration vs osmolality calibration curve	111
Figure B- 3:Ammonium bicarbonate conductivity calibration as a function of concentration.....	112

LIST OF TABLES

Table 2-1:Concentration of hydrolysed urine from a numbers of sources in literature	7
Table 2-2:Components of stored hydrolysed urine including their re-use potential and unfavourable impacts (Udert et al,2015)	9
Table 2-3:Overview of available desalination technologies(Fritzmann et al., 2007)	10
Table 2-4: Membrane processes and their operating conditions, materials ,modules, thickness and pore size (Wagner, 2000, Kochubovski, 2007).....	11
Table 2-5:Draw solutions used in literature and the methods applied in their recovery (Zhao et al., 2012)	16
Table: 3-1Analytical equipment used during experimentation.....	34
Table 3-2: Specifications for the Chloride Analyzer 926	36
Table: 3-3 Operating conditions during the osmotic backwash experiments	41
Table 4-1: Composition of the stored urine used in this study	45
Table 6-1: Calorific value of sludge and an approximation of the sludge required to produce a 1000 L of product water.....	68
Table B- 1: Comparison of the osmotic pressure of NaCl obtained from Literature and that obtained through the use of the Van` t Hoff Equation.....	108
Table B- 2:Comparison of the osmotic pressure of ammonium bicarbonate obtained from literature and that obtained through the use of the Van` t Hoff Equation	108
Table B- 3:Osmotic pressure of ammonium bicarbonate obtained from literature and that obtained through the use of PHREEQ C	108
Table B- 4:Values used to calculate the osmotic pressure of urine during the filtration process through the use of PHREEQ C. Species concentration were measured after every 2 h	109
Table B- 5:Measured bulk osmolality of urine and ammonium bicarbonate obtained during the filtration runs.....	110
Table B- 6:Measured bulk osmolality of urine and ammonium bicarbonate draw solution and their osmotic pressure obtained through the use of the Van` t Hoff` s equation.....	110
Table B- 7PHREEQ C estimation of the osmotic pressure of urine based on the individual species concentrations	110
Table B- 8:Water flux as a function of ammonium bicarbonate concentration	113
Table B- 9	113
Table B- 10: during the 8 h run with stored urine as the feed solution and 2 M ammonium bicarbonate as the draw solution	114

LIST OF ABBREVIATIONS

AL	Active Layer
BMGF	Bill and Melinda Gates Foundation
CEOP	Cake Enhanced Osmotic Pressure
CP	Concentration Polarisation
DI	Deionised
DS	Draw Solution
ECP	External Concentration Polarization
FO	Forward Osmosis
FS	Feed Solution
HTI	Hydration Technology Inc.
ICP	Internal Concentration Polarisation
MBR	Membrane Bio-Reactor
NASA	National Aeronautics and Space Administration
NF	Nanofiltration
NOM	Natural Organic Matter
PBI	Polybenzimidazole
PES	Polyether Sulphone
PRG	Pollution Research Group
PRO	Pressure Retarded Osmosis
RO	Reverse Osmosis
RTTC	Reinvent The Toilet Challenge
TFC	Thin Film Composite
TMA	Trimethylamine
UD	Urine Diversion

NOMENCLATURE

A	Water permeability coefficient ($\text{m s}^{-1} \text{Pa}^{-1}$)
a_j	Activity of species j
C	Solute number density (1/L)
D_s	Diffusion coefficient (m/s)
J_w	Water flux ($\text{L/ m}^2 \cdot \text{h}$)
K	Solute diffusion resistance (s/m)
K	Boltzmann's constant ($1.38 \times 10^{-3} \text{ J/K}$)
M	Solute molar concentration (mol/L)
m_i	Molality of charged species i, (mol/kg)
m	Moles of solute (mol)
R	Gas constant ($0.08314 \text{ L bar /mol. K}$)
S	Membrane area available for flux (m^2)
T	Absolute temperature (K)
T	Thickness of the membrane (m)
Δt	Time interval (h)
ΔV	Volume change (L)
V_F	Volume of feed water
V_F^0	Initial volume of feed water
V_m	Partial molar volume of water (0.018067 L/mol at 25°C for dilute solutions)
V_p	Volume of permeate (L)
ΔW	Change in mass (kg)

GREEK LETTERS

π	Osmotic pressure (bar)
-------	------------------------

$\pi_{F,b}$	Bulk osmotic pressure of the feed solution (bar)
$\pi_{D,b}$	Bulk osmotic pressure of the draw solution (bar)
φ	Osmotic pressure coefficient
ε	Porosity of support layer
τ	Tortuosity of support layer
σ	Reflection Coefficient
ρ	Density of water kg/m ³

1 INTRODUCTION

Improved sanitation where waste treatment and nutrient recovery are sustainably managed is a basic need in poor zones of developing countries where people lack access to adequate sanitation. More than 2.5 billion people - with 1.7 billion living in Asia, and a quarter in sub-Saharan Africa – currently lack access to improved sanitation facilities and practice open defecation (Freeman et al., 2013, Winker et al., 2009, Udert et al., 2015, Silva et al., 2016). This exposure to unimproved sanitation facilities is not only a threat to human health but also to the well-being.

The twin scenarios of an energy crisis and water scarcity have spurred the development of innovative sanitation systems that are cost effective and sustainable. Recently, a lot of effort has been put into finding ways of sustainably managing different wastewater streams with varying compositions i.e., black water (flush water, urine and faeces), grey water (bathing and laundry waste water) and yellow water which is urine. (Zhang et al., 2014, Bischel et al., 2016, Vinnerås, 2002) .

Human excreta has the potential to be converted into valuable resources such as fertilizer and reuse water after separation at source. Urine contributes a high fraction of the nutrients emanating from domestic wastewater in the form of nitrogen, potassium and phosphorous. However, the urine contribution to domestic wastewater total volume is below 1 %, thus making the recovery of nutrients from urine an important motivation for its separation at source (Zhang et al., 2014, Höglund et al., 2000, Vinnerås, 2002). Urine is the biggest phosphorous source from urban areas (Zhang et al., 2014, Bischel et al., 2016, Udert et al., 2015). Urine treatment can additionally assist wastewater treatment plants by reducing their nutrient loadings. Wilsenach and Van Loosdrecht (2004) reported that at least 80 % and 46 % of respectively the nitrogen and phosphate load encountered in municipal wastewater comes from urine. Furthermore, properly designed urine diversion dry toilets (UDDT) can help in the drive to save energy and water. UDDT toilets have separate outlets for urine and faeces to ensure that the two streams are separate (von Münch, 2009).

The recovery of nutrients and reuse water from urine can be carried out through a number of processes (as shown in Figure 1-1) that include struvite precipitation and ammonia stripping. These processes achieve reasonable nutrient recovery, but they are costly in terms of the energy and chemicals required to effect the separation. Zhang et al. (2014), reported that recovering NPK within a single process unit was nearly impossible. Capital and operating costs limit the viability, for example ammonia stripping required an additional odour control unit which increases the operational costs.

The ability of membranes to separate compounds from a solution is promising for urine treatment and nutrient recovery due to their ability to meet sustainability criteria in terms of flexibility and adaptability, ease of use and small footprint (Le and Nunes, 2016). Osmotic membrane processes are

capable of separating water from salts, and in the case of urine treatment, a membrane filtration process permits the reuse of water and the salt concentrate (fertilizer).

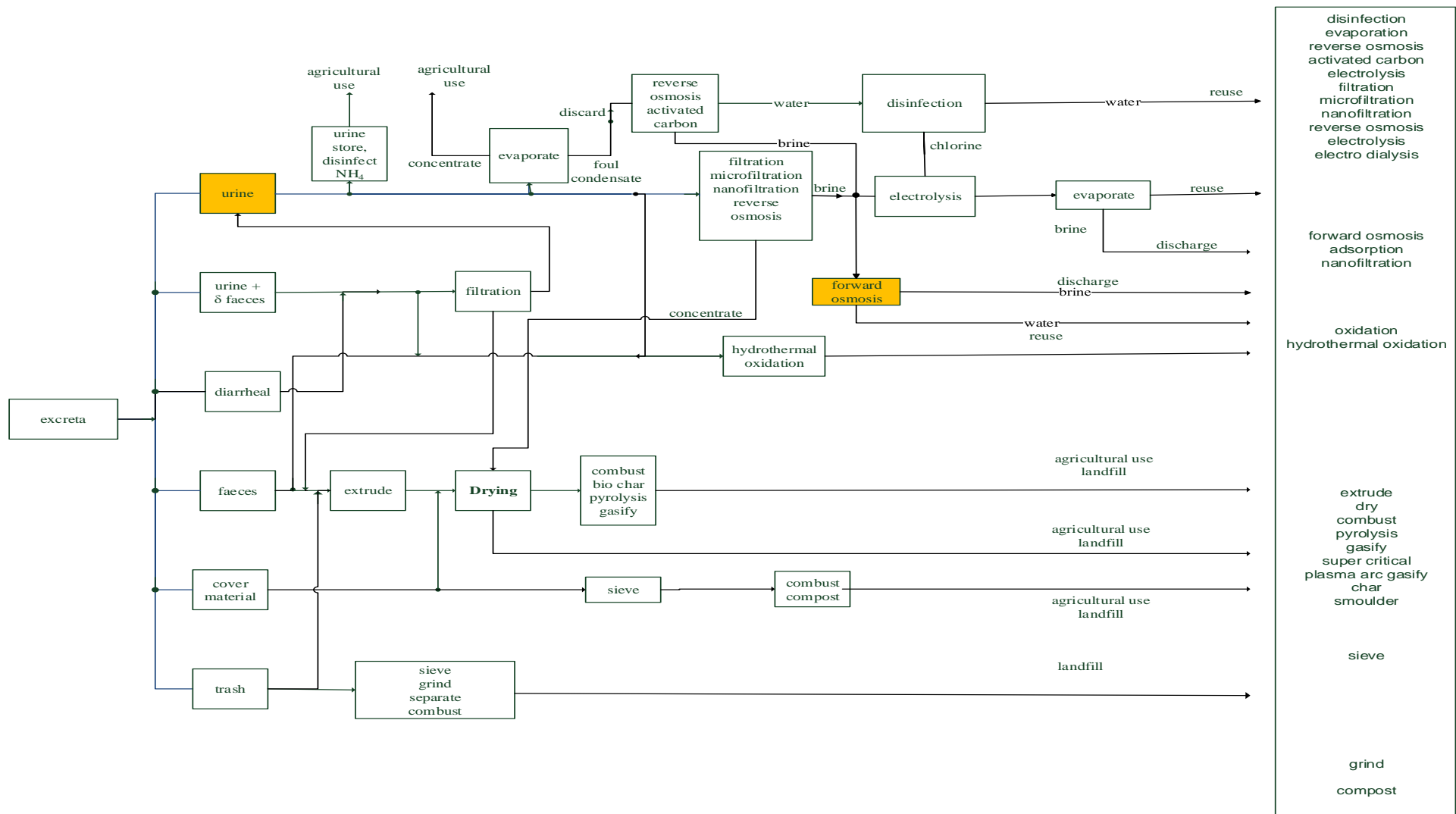

Figure 1-1:Flowchart indicating various processes that can be adopted in processing excreta (PRG Internal discussion document,2016)

Currently, forward osmosis (FO), an osmotically driven membrane process is receiving considerable interest in the research and industrial fields. Its applications in the treatment of both sea and waste water are on the rise. Forward osmosis involves the transport of water molecules past a partially permeable membrane from a feed solution (FS) with low solute concentration towards a draw solution (DS) with high solute concentration. The solute differential between the feed and draw solution is the driving force for water movement in FO unlike in RO where externally applied hydraulic pressure forces water to move against the concentration gradient. FO has proven to be a cost effective, energy efficient, environmentally friendly and easy to scale up alternative compared to RO (Pendergast et al., 2016, Lutchmiah et al., 2014b). Most importantly, less membrane fouling has been reported (Jackson, 2014). The attractiveness of FO is further enhanced if the draw solution can be recovered in a cost effective way, for example through the use of low grade heat.

The Pollution Research Group (PRG) from the University of KwaZulu-Natal, where this work was carried out is one of the grantees of the Reinvent the Toilet Challenge (RTTC) which is funded by the Bill & Melinda Gates Foundation (BMGF). This work was carried out within the RTTC context. RTTC focusses on the development of new and sustainable toilets technologies. The reinvented toilet should accept all the usual items which are disposed to a toilet (faeces, urine, detritus, papers or wiping material), cost less than 0.10 US dollars per day per individual, be off the electric grid, water and sewerage system whilst remaining hygienic. Additionally, the reinvented toilet should recover valuable resources from the human excreta, such as water, fertilizer and energy and kill pathogens (McCoy et al., 2009, Woolley et al., 2014, Elledge and McClatchey, 2013, Randall et al., 2016).

In light of the above objectives of the RTTC, FO was selected for investigation. In the context of the RTTC an FO membrane capable of achieving high solute rejections is desirable. High rejections entails desirable concentration of the urine feed stock, minimised loss of the nutrients of interest (Potassium, Nitrogen and Phosphorous) and a good quality of the permeate. The sum benefit of these high rejections will be low operational costs. UDDT toilets can be coupled to the FO technology for urine processing.

Limited work has been reported in literature on the treatment of stored hydrolysed urine using forward osmosis. The National Aeronautics and Space Administration (NASA) used FO to recycle water from urine for their advanced life support systems in space applications Gormly and Flynn (2007). Zhang et al. (2013) attempted to utilise FO in the recovery of nutrients (N, P, K) from source separated urine. However, it is important to note that the few studies used synthetic urine recipes to mimic real urine.

This research will attempt to fill in the lack of information on the use of FO as an alternative process to desalinate urine. The research reported in this thesis describes the separation of stored hydrolysed urine by forward osmosis utilising ammonium bicarbonate as the draw solution. The data obtained from this study will provide knowledge with regards to the use of forward osmosis membranes in the separation

of water and nutrients from urine. Additionally, the investigation will allow the evaluation of the feasibility of FO as a suitable urine treatment process.

1.1 Aim and Scope

In this project, stored hydrolysed urine will be utilised due to its stability compared to fresh urine. It is also difficult to obtain fresh urine because it hydrolyses very quickly soon after leaving the human body. Additionally, in a real process, urine is most likely to go through a pretreatment stage before desalinating it and by that time it would have hydrolysed. The reclamation of permeate water from the draw solution after it is diluted will not be investigated in this project. The research will be conducted in a batch scale laboratory set-up.

1.2 Objectives

The specific objectives of the project were:

- (a) To evaluate water flux by varying draw solution concentration
- (b) To evaluate the membrane fouling propensity and its reversibility
- (c) To investigate the membrane rejections of urine compounds
- (d) To develop a mass balance framework that describes the separation process and compare its results with experimental data.

1.3 Outline of the dissertation

Chapter One introduces the study and outlines the aim and scope of the study. This chapter also gives the objectives of the study.

Chapter Two provides a literature review on urine and forward osmosis. It begins with a background on urine, focusing mainly on stored hydrolysed urine. The second part consists of a definition of forward osmosis, its applications and challenges associated with it. The major challenges associated with FO, which are concentration polarisation (CP), fouling and reverse draw solute diffusion are discussed in depth.

Chapter Three explains the materials utilised in the study and the methodology adopted to fulfil the objectives of the study. Methods and equations used to evaluate important parameters are also discussed.

Chapter Four presents the major results and the subsequent discussion.

Chapter Five presents various conclusions drawn from the study and gives recommendations.

2 LITERATURE REVIEW

In the previous chapter forward osmosis (FO) was introduced and the aims and objectives of this thesis were outlined. In this chapter the relevant literature will be reviewed in order to understand the principles that govern FO. Three aspects with regards to the present study are treated in the literature review. Firstly, the feedstock, stored hydrolysed urine is described. Secondly, the general aspects of forward osmosis (FO) are discussed and lastly factors that influence FO with emphasis on fouling and membrane cleaning.

2.1 Human urine generation

Human urine is an aqueous solution secreted by the kidneys. It is filtered from the blood and is expelled via the urethra. Urine is composed of at least 91 % water, organic compounds, inorganic salts and urea. Urine contains the major daily bodily excretion of nitrogen (N), phosphorous (P) and potassium (K) contributing 88 %, 67 % and 73 %, respectively (Stevenson et al., 2000, Taylor and Curhan, 2006, Udert et al., 2003, Karak and Bhattacharyya, 2011).. The majority of nitrogen found in fresh urine exist as urea (CH_4N_2O). A comprehensive list of the 68 constituents of human urine that have individual maximum concentrations exceeding 10 mg/L was provided by Beach (1971).

Rose et al. (2015) state in an extensive literature review that the range for an adult urinary output is between 0.4 to 2 L of urine daily with a normal intake of 2 L of water daily. The same authors also emphasise that fluid consumption has a huge effect on the total urine production. It is important to note that urine composition is a function of: total water intake, eating habits, environmental conditions, exercise regime and these may vary from one region to the other depending on the person. The total concentration of solutes per kilogram of solvent in urine is called osmolality and this value ranges between 50 to 1200 mOsmo/kg (Rose et al., 2015). In medical fields, osmolality is used to give an indication of the osmotic pressure exerted by urine. Beach (1971), reports that urine has an approximate osmotic pressure of 15 bar. The pH value of fresh urine ranges between 5.5 to 7.

2.1.1 Urea Hydrolysis

During the storage of urine, urea hydrolyses quickly due to degradation by urease enzyme .This results in ammonia being formed and the pH subsequently increases above 8 thus triggering the precipitation of struvite, hydroxyapatite and calcite precipitates which have low solubility (Udert et al., 2003). The hydrolysis reaction is shown in Equation (2.1)(2.1) (Hellström et al., 1999). Ammonium can turn into dissolved molecular ammonia due to the high pH as seen in Equation (2.2)(2.2). Dissolved ammonia is in equilibrium with gaseous ammonia as shown in Equation (2.3)(2.3).



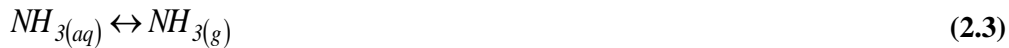

The composition of hydrolysed urine from a number of sources is presented in [Table 2-1](#) ~~Table 2-1~~. The evaporation of ammonia during collection, storage, transport and use poses major challenges in urine handling systems and this calls for the stabilization of urine. Urine stabilization prevents organic matter degradation (which causes odour), volatilization of ammonia and the formation of precipitates (causing clogging of pipes). Hellström et al. (1999) reported the use of acetic or sulphuric acid to stop urea from decomposing. The acidification of urine lowers its pH to around 4.

Nitrification can also be used to stabilize urine. The product of nitrification is not only a stable solution containing non-degradable substances but one that also lacks the odour normally associated with urine (Maurer et al., 2006, Fatta-Kassinos et al., 2009).

Table 2-1: Concentration of hydrolysed urine from a numbers of sources in literature

Parameters	Values/Description	References
pH	8.90-8.96	(Kirchmann and Pettersson, 1994)
	9.00-9.10	(Nordin et al., 2009)
	9.20	(Pradhan et al., 2010)
	8.25-8.55	(Golder et al., 2007)
	14.8-31	(Jönsson et al., 2000)
Conductivity (mS/cm)	14.8-31	(Jönsson et al., 2000)
Na (g/L)	0.938-0.982	(Kirchmann and Pettersson, 1994)
K (g/L)	0.875-1.150	(Kirchmann and Pettersson, 1994)
	2.00	(Pradhan et al., 2010)
	0.7-3.3	(Meinzinger and Oldenburg, 2009)
	0.59-1.3	(Pradhan et al., 2007)
Cl ⁻ (g/L)	2.24-2.50	(Kirchmann and Pettersson, 1994)
	3.03	(Pradhan et al., 2010)
	8.36	(Pradhan et al., 2010)
Total Nitrogen (g/L)	1.8-17.5	(Meinzinger and Oldenburg, 2009)
	8.00	(Ban and Dave, 2004)
	1.117-1.726	(Kirchmann and Pettersson, 1994)
NH ₄ ⁺ -N (g/L)	2.4-3.10	(Pradhan et al., 2007)
	2.10	(Nordin et al., 2009)
NH ₃ -N (g/L)	2.10	(Nordin et al., 2009)
NO ₃ ⁻ -N (g/L)	0.01	(Pradhan et al., 2010)
Total Phosphorous (g/L)	0.2-3.7	(Meinzinger and Oldenburg, 2009)
	0.20-0.21	(Kirchmann and Pettersson, 1994)
	0.59-1.3	(Pradhan et al., 2007)

2.1.2 Existing technologies for urine treatment

Recoverable nutrients from urine should be in a state that permits either agricultural use or subsequent processing in industry. In addition to this, urine treatment should prevent the negative effects such as hygienic risks, malodour and environmental pollution. Eutrophication in urban areas and high concentrations of nitrates in groundwater of sub-Saharan Africa have been attributed to inadequate sanitation (Nyenje et al., 2010).

The upside of urine treatment is that urine contains nitrogen, phosphorous and potassium that can be utilised as fertilizer thus closing the nutrient cycle to agriculture. Additionally, environmental impact is also reduced by minimising the production of synthetic fertilizers.

The following processes for urine treatment have been mentioned in literature (Udert et al., 2015).

- The use of precipitation to recover phosphorous ((Etter et al., 2013);(Antonini et al., 2011); (Udert et al., 2015)). Udert et al. (2015) report that struvite precipitation can be implemented in the field with ease. It should be noted that struvite precipitation recovers at least 95 % of the phosphate.
- Ammonia stripping (Antonini et al., 2011, Xu et al., 2015);
- The use of solar evaporation and acidification (Udert et al., 2015, Xu et al., 2015).
- Nitrification/ Distillation (Udert et al., 2015). This combination is preferred for its ability to completely recover all nutrients.
- Electrolysis is preferred as it permits the construction of small reactors that can be part of a toilet facility (Udert et al., 2015).
- Ozonation, microfiltration and electrodialysis (Pronk et al., 2007)

Implementation of the processes enumerated above to treat urine hinges on costs, reliability and the ease of operation. Additional uses of the components found in urine are summarised in Table 2-2, as well as possible negative impacts.

Table 2-2: Components of stored hydrolysed urine including their re-use potential and unfavourable impacts (Udert et al,2015)

Compound	Beneficial reuses	Negative impacts
Water	Recycling; (example for irrigation)	Tanks required for water storage Weight becomes a factor during transportation
Nitrogen	Fertilizer Input to the fertilizer industry	The toxicity and unbearable smell of ammonia Contamination of ground water, endanger fish, pollution of the environment
Phosphorus	Fertilizer Input to the fertilizer industry	Eutrophication Blockage of valves and pipes
Bicarbonate	None	Blockage of valves and pipes
Sulfur	Fertilizer Raw product for chemical industry	Environmental pollution Smell and toxicity of hydrogen sulfide
Potassium	Fertiliser Raw product for chemical industry	Salinization of agricultural soils and groundwater
Sodium	osmotic adjustment and suppression of plant diseases	Stunted growth, wilting and plant stress
Chloride	photosynthesis, osmotic adjustment and suppression of plant diseases	Stunted growth, wilting and plant stress
Organic substances(bulk)	None	Terrible smell Foaming which can cause problems during subsequent treatment
Trace organic compounds	None	Threats to human health Pollution of the environment
Pathogens	None	Threats to human health

2.2 Generalities of forward osmosis (FO)

In this section the following aspects with regards to forward osmosis are discussed: membrane separation processes, forward osmosis, osmotic pressure, draw solution, forward osmosis membranes and modules and forward osmosis applications.

2.2.1 Introduction to membrane separation

Urine can be considered as brine due to its high salt content and therefore desalination which is defined as the separation of salt from a solvent (Lattemann and Höpner, 2008) can be applied in the treatment of urine. Desalination methods that can be applied to urine are summarised in [Table 2-3](#) ~~Table 2-3~~.

Table 2-3: Overview of available desalination technologies (Fritzmann et al., 2007)

Thermal desalination technologies	Membrane based desalination technologies
Ion exchange	Reverse Osmosis
Multi-effect distillation	Membrane distillation
Humidification and Dehumidification	Microfiltration, ultrafiltration, nanofiltration
Vapour compression distillation	Electrodialysis
Eutectic freezing	Electrodialysis Reversal (EDR)
Multi-stage flash distillation	Continuous EDR

The majority of membrane separation technologies are customarily pressure driven processes, governed by mass transfer phenomena to partition suspended and dissolved material from solutions (Coday et al., 2014, Vane, 2008, Strathmann, 2004). Membrane filtration is capable of removing suspended solids, nutrients (including N and P), chemical oxygen demand (COD) and pathogens (including viruses). The filtration is facilitated by the membrane: - a thin semipermeable film that acts as a selective barrier that selectively removes contaminants within the feed solution. The membrane's ability to reject contaminants in the feed solution is determined by the pore size, pore geometry and the membrane charge density. The degree of electrostatic repulsion of the feed contaminants depends on the charge density on membrane surface. The molecular size of the contaminants and operating pH also influence the suitability of a membrane for a particular operation (Valladares Linares et al., 2011).

NF, UF, MF and RO are the common membrane separation technologies that require external pressure to drive the filtration and their main attributes including pore size and operating pressures are summarised in Table 2-4. MF and UF are capable of rejecting large molecules and particles whilst NF can reject small molecules and poly valent ions. RO is capable of satisfactorily rejecting sodium and chloride ions and low molecular weight organic compounds but not dissolved gases (ammonia and carbon dioxide) (Fakhru'l-Razi et al., 2009). RO and NF can handle the most extreme of impaired feeds and still manage to achieve reasonable rejections. However, their effectiveness is limited by their elevated susceptibility to inorganic scaling, biological and organic fouling which consequently leads to increased pressure loss, low water recovery and high cleaning costs (Fakhru'l-Razi et al., 2009, Sutzkover-Gutman and Hasson, 2010). The variety of streams in pressure driven membranes that can

be treated is also limited by the requirement to surpass the feed stream osmotic pressure (Coday et al., 2014, Phuntsho, 2012).

Table 2-4: Membrane processes and their operating conditions, materials ,modules, thickness and pore size (Wagner, 2000, Kochubovski, 2007)

	Reverse Osmosis(RO)	Nanofiltration(NF)	Ultrafiltration(UF)	Microfiltration(MF)
Membrane	Asymmetrical	Asymmetrical	Asymmetrical	Symmetrical Asymmetrical
Thickness	150 μm	150 μm	150-250 μm	10-150 μm
Thin film	1 μm	1 μm	1 μm	
Pore size	< 0.002 μm	< 0.002 μm	0.2-0.02 μm	4-0.02 μm
Rejection of	Predominantly amino acids, sodium chloride and glucose. HMWC,LMWC	HMWC, mono-,di-and oligosaccharides polyvalent negative ions	Macromolecules, protein, polysaccharides, virus	Particles ,clay, bacteria
Membrane material(s)	Cellulose Acetate, Thin film	Cellulose Acetate, Thin film	Ceramic, PP, PVDF, Cellulose acetate, Thin film	Ceramic,PP,PSO,PVDF
Membrane module	Tubular, spiral wound ,plate and frame	Tubular, spiral wound ,plate and frame	Tubular, hollow fibre, spiral wound, plate and frame	Tubular, hollow fibre
Operating pressure	15-150 bar	5-35 bar	1-10 bar	< 2 bar

Note: HMWC-High molecular weight compounds; LMWC-Low molecular weight compounds
PP- Polypropylene; PVDF-Polyvinylidene Fluoride; PSO-Polysulphone; PV-Polyvinyl;

The current state-of-art for water purification and desalination is RO. This technology recovers pure water from a solution by pressurizing it beyond its osmotic pressure. The RO membrane retains the solutes allowing only the water to pass. The RO process generally requires pressures above 15 bar, which results in high energy requirement and subsequently high operational cost (McGinnis, 2002, Wagner, 2000, Sairam et al., 2011). In the case of urine, the system will have to exceed the osmotic pressure of the solution, initially at 15 bar. A considerable energy consumption will be then required for the solution pressurization.

An alternative membrane technology that is currently gaining popularity is forward osmosis (FO) where the filtration is powered by the osmotic pressure gradient between the solution to filter and the draw solution. Moreover, the substantially lower hydraulic pressure leads to less membrane fouling (Elimelech and Phillip, 2011, Zou and He, 2016). Robust and modular treatment, high rejection of contaminants in the feed stream and high permeate recovery are some the benefits of using FO (Coday et al., 2014, McCutcheon et al., 2006). Forward osmosis can be utilised as a standalone separation process, or as a pre-treatment process for NF or RO.

The following sections details the principles of FO, definitions associated with the process, applications of the FO process, challenges and draw backs of the process and its applicability in the current study.

2.2.2 Definition of forward osmosis

Osmosis is the diffusion of solvent molecules from a region of higher water potential to a region of lower water potential through a selectively permeable barrier. The difference in water potential, which represents the inherent energy of this process is due to the solute concentration gradient that exist between the two solutions (Tan et al., 2012).

Forward osmosis (FO) is the transport of water molecules past a selectively permeable barrier from a low solute concentration feed solution to a higher solute concentration draw solution (Phuntsho et al., 2011, She et al., 2012). The barrier (membrane) permits the movement of water whilst rejecting dissolved and suspended constituents. Water may be extracted from the diluted draw solution in a subsequent process (Coday et al., 2014, McGinnis, 2002). The movement of water molecules from the feed solution towards the draw solution past the membrane is powered by the osmotic pressure gradient, $\Delta\pi$, between the two solutions. Calculating $\Delta\pi$, as shown in Equation 2.4, enables the quantification of the osmotic pressure gradient that powers the FO process. The general equation governing the water transport in (FO), as well as in (RO) is given in Equation 2.5.

$$\Delta\pi = \pi_{DS} - \pi_{FS} \quad (2.4)$$

$$J_w = A(\sigma\Delta\pi - \Delta P) \quad (2.5)$$

Where

$\Delta\pi$ = osmotic pressure differential (Pa)

π_{DS} = draw solution osmotic pressure (Pa)

π_{FS} = feed solution osmotic pressure (Pa)

J_w = water flux (L.m²/h)

A = permeability constant (m /s. Pa)

ΔP = applied hydraulic pressure (Pa)

σ = reflection coefficient of the membrane

The symbols used in all the equations in this thesis are according to the symbols given in the nomenclature.

The reflection coefficient (σ) is an indicator of how permeable a specific membrane is to a specific solute. For a semi-permeable membrane, the reflection coefficient is assumed to be 1 and hence Equation 2.5 simplifies to Equation 2.6 in the case of FO where the applied pressure is zero. A

membrane that permits movement of solutes and solvents at the same rates would have $\sigma = 0$. (Yong et al., 2012, Phuntsho, 2012).

$$J_W = A(\pi_{DS} - \pi_{FS}) \quad (2.6)$$

The osmotic pressure gradient and applied pressure determine the direction of water movement in both FO and RO respectively as illustrated in Figure 2-1 .

In FO, $\Delta P = \text{zero}$; movement of water is towards the highly concentrated solution.

In RO, $\Delta P > \Delta \pi$, applied external pressure causes water to move towards the less concentrated solution.

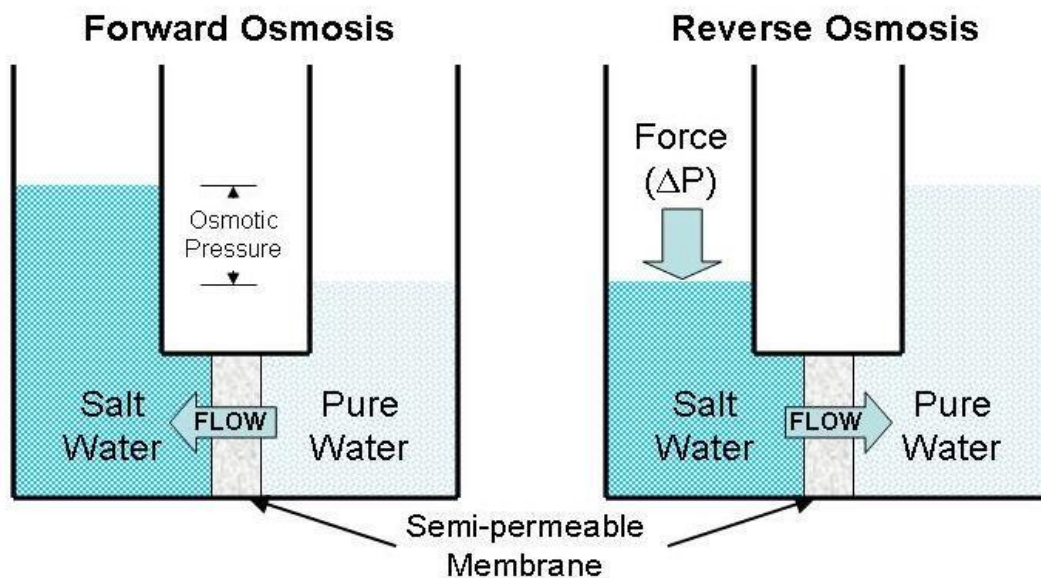

Figure 2-1: Schematic diagrams of the Forward Osmosis Process illustrating the direction and magnitude of water flux in FO, and RO .

2.2.3 Calculation of osmotic pressure

The osmotic pressure of dilute solutions can be estimated by the Van't Hoff Equation:

$$\pi = MRT \quad (2.7)$$

Where

M = solute concentration (mol/L)

R = universal gas constant (0.08314 L bar/mol K)

T = temperature (K)

The above equation is extended for non-ideal behaviour in concentrated salt solutions yielding the following equation

$$\pi = \varphi MRT \quad (2.8)$$

Where

φ = osmotic pressure coefficient. Deviation from ideality is taken into account by the virial equation in Equation 2.9. Stastical thermodynamics explains how the solute number density is related to the osmotic pressure:

$$\frac{\pi}{kT} = c + Bc^2 + Cc^3 + \dots \quad (2.9)$$

Where

k = Boltzmann's constant ($1.380 \times 10^{-23} \text{ kgm}^2/\text{s}^2\text{K}$)

and data from experiments yields the coefficients ($B, C..$). The following equation defines the solute number density

$$c = \frac{N_A n}{V} \quad (2.8)$$

Where

N_A = Avogadro's number (6.022×10^{23})

(n/V) = solute molar volume concentration

Dow membrane manufactures use the following formula to calculate the osmotic pressure (Jacob,2016)

$$\pi = 1.12(273+T) \sum m_j \quad (2.9)$$

Where

$\sum m_j$ = sum of individual molality of components that make up a solution (moles of solute/kg of solvent)

The molality is calculated by dividing the moles of solute by the kilograms of solvent or can be obtained directly from osmometer measurements.

2.2.4 Draw solution

In FO, the high osmotic pressure solution is called a draw solution (McCutcheon et al., 2005, Phuntsho, 2012). The draw solution drives the process in order to obtain water from the feed solution. This makes the selection of an appropriate draw solution a crucial step prior to application (Achilli et al., 2010). In

literature the draw solution maybe referred to as brine, osmotic (media, agent) and driving solution. (Cath et al., 2006). In this thesis, this solution will be referred to as draw solution.

The draw solution should also satisfy the following criteria in addition to being capable of generating high osmotic pressure:

- Consume less energy during reclamation
- Non-toxic
- Should be separable from the diluted draw solution with ease
- Easily separable from the diluted draw solution
- Highly soluble
- Chemically inert

Back diffusion of the draw solution solutes to the feed tank is also an important criterion. The use of multivalent ion solutions as draw solutions has been suggested (Cath et al., 2006). Figure 2-2 depicts different draw solutions with the corresponding osmotic pressures they are capable of generating at different molar concentrations. The graph shows that the osmotic pressure generated is linearly related to draw solution concentration. Although magnesium chloride is capable of generating the highest osmotic pressure relative to the rest of the salts as shown in Figure 2-2, it is widely considered an unsuitable draw solution due to the difficulty of recovering permeate water after FO. The application of a reverse osmosis step is then necessary after the forward osmosis process in this case (Chung et al., 2012).

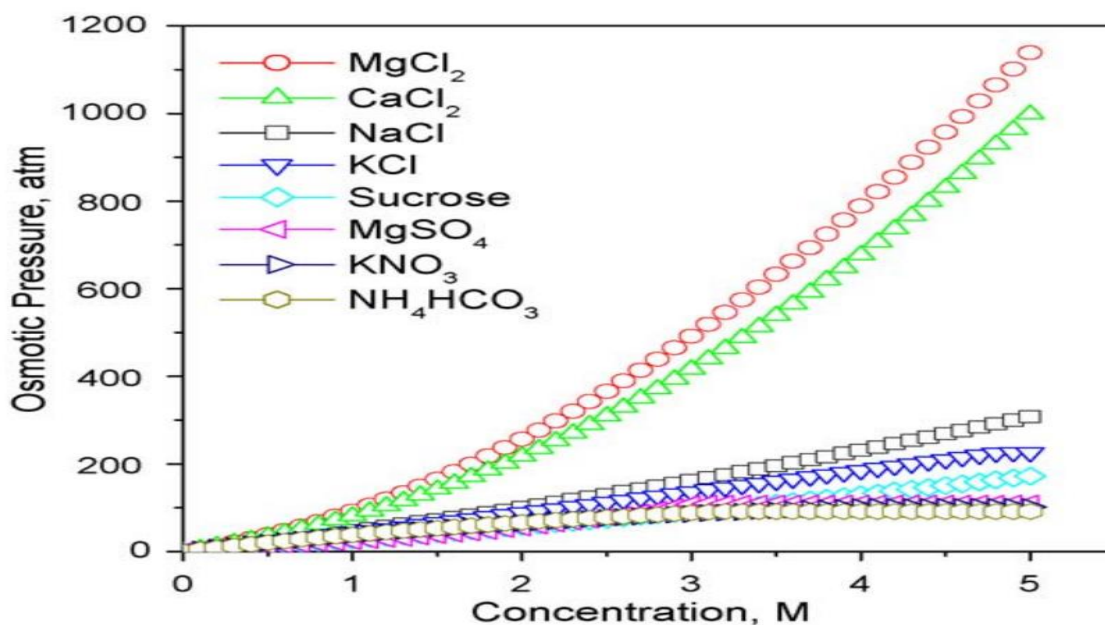

Figure 2-2: Osmotic pressure as a function of solution concentration at 25 °C for various draw solutions (Cath et al., 2006)

Different chemicals have been tested in the past to ascertain their suitability as draw solutions (McGinnis, 2002). ~~Table 2-5~~ ~~Table 2-5~~ summarizes various draw solutes/solutions that have been used in literature and their respective recovery methods

Ammonium bicarbonate has recently registered great success as a draw solution (McGinnis and Elimelech, 2008). Laboratory experiments have been undertaken to demonstrate its suitability and technical feasibility (McCutcheon et al., 2006). The ability of ammonium bicarbonate to satisfy the above criteria for an ideal draw solution has led to its widespread use.

Table 2-5: Draw solutions used in literature and the methods applied in their recovery (Zhao et al., 2012)

Scale of application	Draw solute/solution	Recovery method	Reference
Laboratory	Volatile solutes (e.g. SO ₂)	Air stripping or heating	(Batchelder, 1965)
Laboratory	Mixture of water and another gas (SO ₂) or liquid (aliphatic alcohols)	Distillation	(Glew, 1965)
Laboratory	Al ₂ (SO ₄) ₃	Precipitation by doping Ca(OH) ₂	(Frank, 1972)
Laboratory	Glucose	None	(Kravath and Davis, 1975)
Laboratory	Nutrient solution	None	(Kessler and Moody, 1976)
Laboratory	Fructose	None	(Stache, 1989)
Laboratory	Sugar	RO	(Yaeli, 1992)
Laboratory	KNO ₃ and SO ₂	SO ₂ is recycled through standard means	(McGinnis, 2002)
Pilot	NH ₄ HCO ₃ (Ammonium bicarbonate)	Moderate heating ($\approx 60^\circ\text{C}$)	(McCutcheon et al., 2005)
Laboratory	Magnetic nanoparticles	Captured by a canister separator	(Adham, 2007)
Laboratory	Dendrimers	Ultrafiltration or pH adjustment	(Adham, 2007)
Laboratory	Albumin	Use of heat	(Adham, 2007)
Laboratory	2-Methylimidazole-based solutes	FO-MD	(Ge et al., 2010)
Laboratory	Magnetic nanoparticles	Recycled by a magnetic field	(Ge et al., 2010)
Laboratory	Stimuli-responsive polymer hydrogels	Deswelling the polymer hydrogels	(Li et al., 2011)
Laboratory	Fertilizers	Unnecessary	(Phuntsho et al., 2011)
Laboratory	Hydrophilic nanoparticles	Ultrafiltration	(Ling and Chung, 2011)
Laboratory	Zwitterions	Biological degradation	(Lutchmiah et al., 2014a)

Ammonium bicarbonate use as draw solution has also been validated through tests in a pilot-scale FO plant (McGinnis et al., 2013). Studies carried out by McGinnis and Elimelech (2007) demonstrated that ammonium bicarbonate can generate high osmotic pressures (above 50 bar) and can be readily separated at relatively low temperatures. In fact, the ammonium bicarbonate breaks down into gaseous carbon dioxide and ammonia upon moderate heating (near 60°C). The possibility of recycling carbon dioxide and ammonia as draw solutes exist. However, McGinnis and Elimelech (2007) point out that the reverse permeation of ammonium and bicarbonate draw solutes can lead to loss of draw solution, thus compromising the sustainability operation of the FO system.

The selection criteria for an appropriate FO draw solution for a particular application is very stringent and needs careful consideration due to the impact that the draw solution has on the overall operational sustainability (economic and environmental) of the process.

Research to find improved draw solutions continues with different research groups in the desalination field probing ways to improve existing draw solutions and the same time taking advantage of the recent technological advancements to develop new ones.

2.2.5 Forward osmosis membranes

In the early days of forward osmosis, materials including animal bladders, nitrocellulose and rubber were tested (Yang et al., 2015). Most of the membranes used in RO have been tried in FO to ascertain the extent of separation that they can achieve (Nguyen et al., 2013).

Technological breakthroughs in forward osmosis membrane materials and fabrication technology have resulted in an expanded scope of applications for the process. The recently developed FO membranes fall into three categories according to their fabrication method: chemically transformed RO membranes, thin film composite membranes (TFC) and cellulose membranes.

Chung et al. (2012) developed FO membranes that were asymmetric by using a phase inversion processes from cellulose acetate, polybenzimidazole (PBI) and polyether sulfone (PES). The polybenzimidazole membrane was modified by Chung and his group and showed relatively good FO performances. The modifications resulted in a dual layer- membrane which had a very thin layer that is highly selective and a microporous support layer (Yang et al., 2009, Yang et al., 2016). The chemical inertia, high hydrophilic character and mechanical strength exhibited by cellulose acetate made it a suitable membrane material which resulted in its use in FO and RO. However, cellulose acetate use as an FO membrane is restricted by the operating temperature and solution pH (Yang et al., 2015) .

The transformation of reverse osmosis membranes to yield new membranes for use in forward osmosis involves the introduction of charged groups on the surface of membranes to enhance their performance. (McCutcheon et al., 2005, Zhao et al., 2012) point out that membranes that are negatively charged and hydrophilic are less likely to experience natural organic matter (NOM) induced fouling.

TFC membranes are made up of an extra-thin layer that is very selective (active layer) and a thicker porous layer that gives mechanical support and strength. The porous layer determines the internal permeate flux whilst the active side controls the solute flux and rejection.

The research for higher water flux and compound rejections led to interest in biological membranes. The concept of incorporating aquaporin properties into desalination membranes was proposed by Tang et al. (2013). Aquaporins are highly selective membrane channel proteins that carry water across membrane cell walls (Nielsen, 2009). They are located in the lipid bilayer of all living cells. Aquaporins are capable of achieving high rejections of multivalent ions thus becoming an alternative low energy filtration system alternatives (Tang et al., 2013).

An ideal FO membrane has high porosity and a support layer with very low tortuosity to reduce flux limitation by internal concentration polarisation (ICP) (described in section 2.3.1).

2.2.6 FO membrane modules

FO membranes can be packed or held in different module configurations which offer merits and constraints that must be considered for different applications. Configurations that are currently under use include spiral wound, tubular e.g. hollow fibres and plate and frame (Cath et al., 2006). Flat sheet membrane together with spiral wound membrane configurations have been tested widely (Hancock et al., 2013, Valladares Linares et al., 2011, Yoon et al., 2013, Peña et al., 2013, Parida and Ng, 2013, Gao et al., 2014).

In a plate and frame module cassette packages are formed by membranes that are separated by spacers. The plate and frame module is capable of holding at least 1 700 flat sheet membranes. Flat sheet membranes are housed within a module with inlet and outlet ports on both sides to allow both solutions (feed and draw) to flow (Chung et al., 2012). Figure 2-3 illustrates the flow pattern in a typical plate and frame module. The draw backs associated with the plate frame module include: larger system size and increased operating expenditure (labour for membrane replacement and monitoring the integrity of the flat sheet membrane) (Cath et al., 2006).

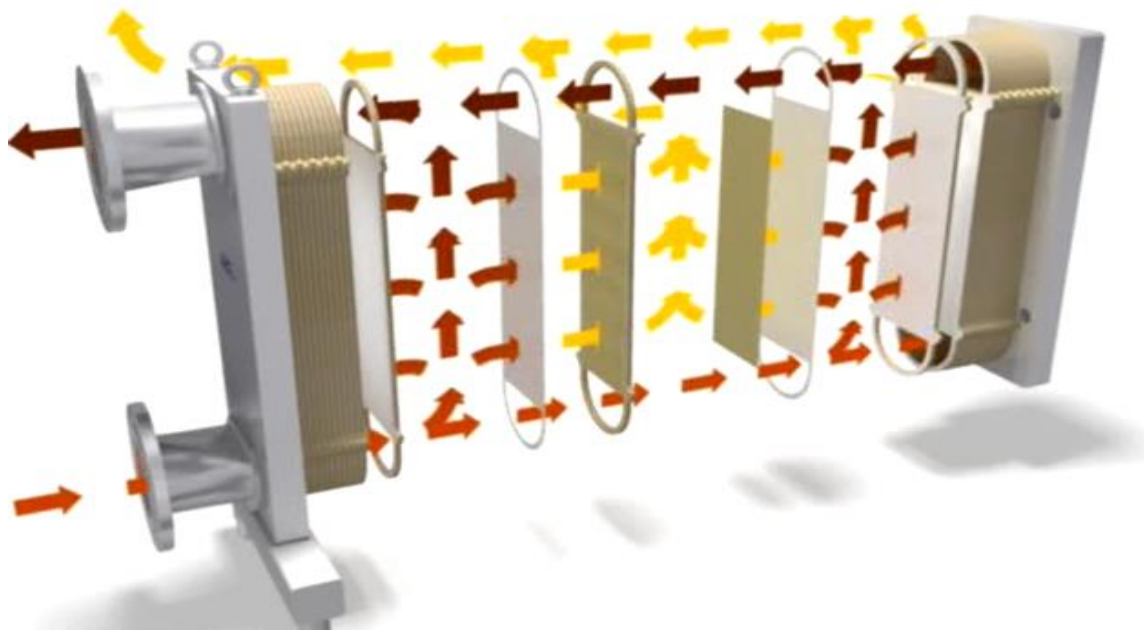

Figure 2-3:Flow pattern in a plate-and-frame module(orange :feed; red: retentate; yellow: permeate)<http://www.alfalaval.com/products/separation/membranes/Modules/#sthash.ncHtPyyT.dpuf> (Accessed on 01 November 2016)

Spiral wound FO elements closely resemble that of RO membranes with additional modifications to the membrane envelope and the central tube that allow forced flow as shown in Figure 2-4 .Spiral wound membranes provide an increased membrane active area relative to the total membrane cell size (Jackson, 2014).

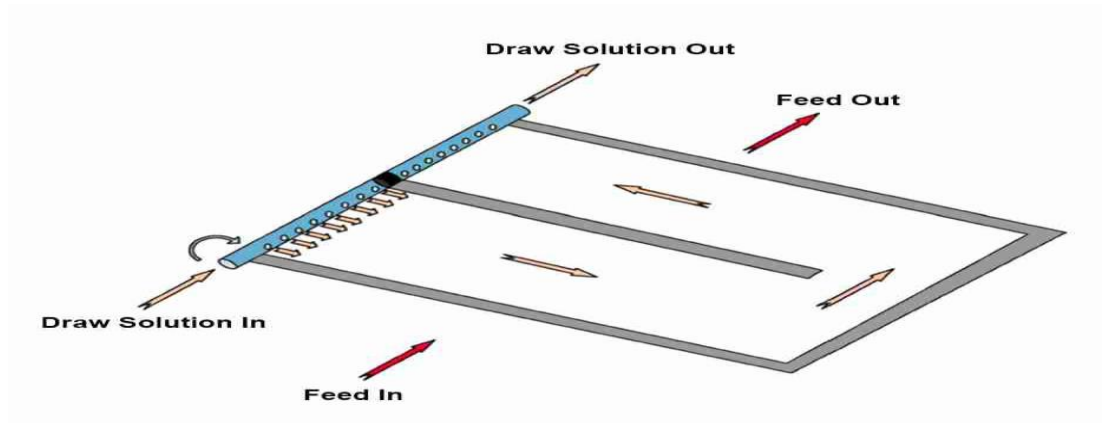

Figure 2-4:Flow patterns in spiral wound modules (Mehta, 1982)

Tubular and hollow fibre forward osmosis membranes are usually packed in huge bundles to increase the packing density of the membrane holding unit as illustrated in Figure 2-5 . Tubular membranes find widespread practical use in continuous FO operations for the following reasons:

- Tubular membranes are self-supported allowing them to withstand high hydraulic pressure without deformation.
- Tubular membrane modules are easier to fabricate and the packing density is relatively high.
- Liquids flow freely on either side of the membrane.

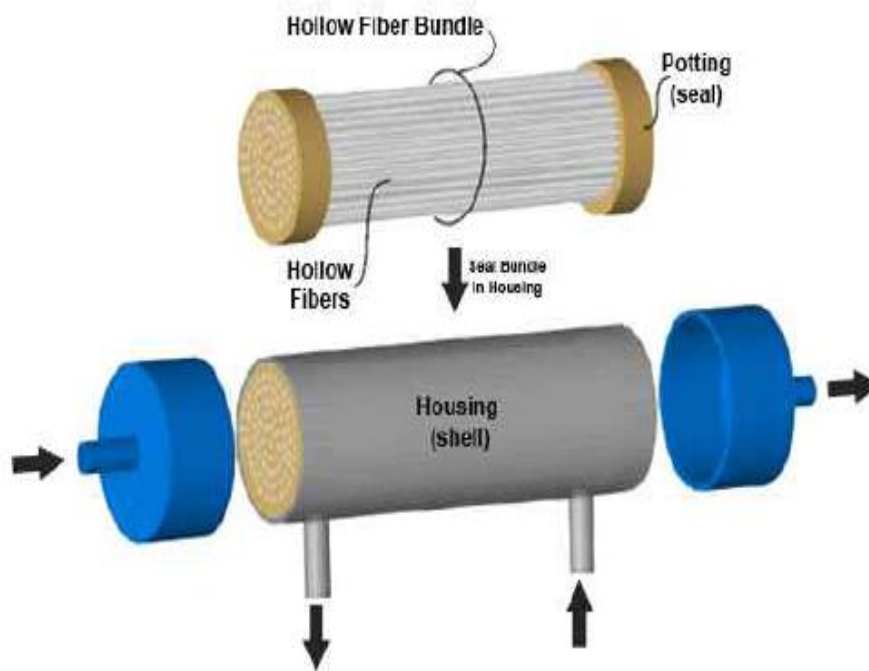

Figure 2-5: Hollow fiber FO membranes grouped in bundles of differing size and potted at each end. (Nunes and Peinemann, 2001)

2.2.7 Forward Osmosis Applications

Applications, though still limited, are emerging including treatment of waste industrial streams (Zhang et al., 2011), contaminated streams from mines (Hickenbottom et al., 2013) and domestic and household waste streams (Achilli et al., 2010), as well as for drying sludge (Nguyen et al., 2013), fruit juice processing (Babu et al., 2006), fertilizer production (Phuntsho et al., 2012), sea water filtration (McCutcheon et al., 2005), and microalgae dewatering (Buckwalter et al., 2013). FO has also been applied by NASA for urine processing during space missions (Cath et al., 2006). The various fields where FO can be applied can be broadly summarised into three categories: water, energy and life sciences as illustrated in Figure 2-6.

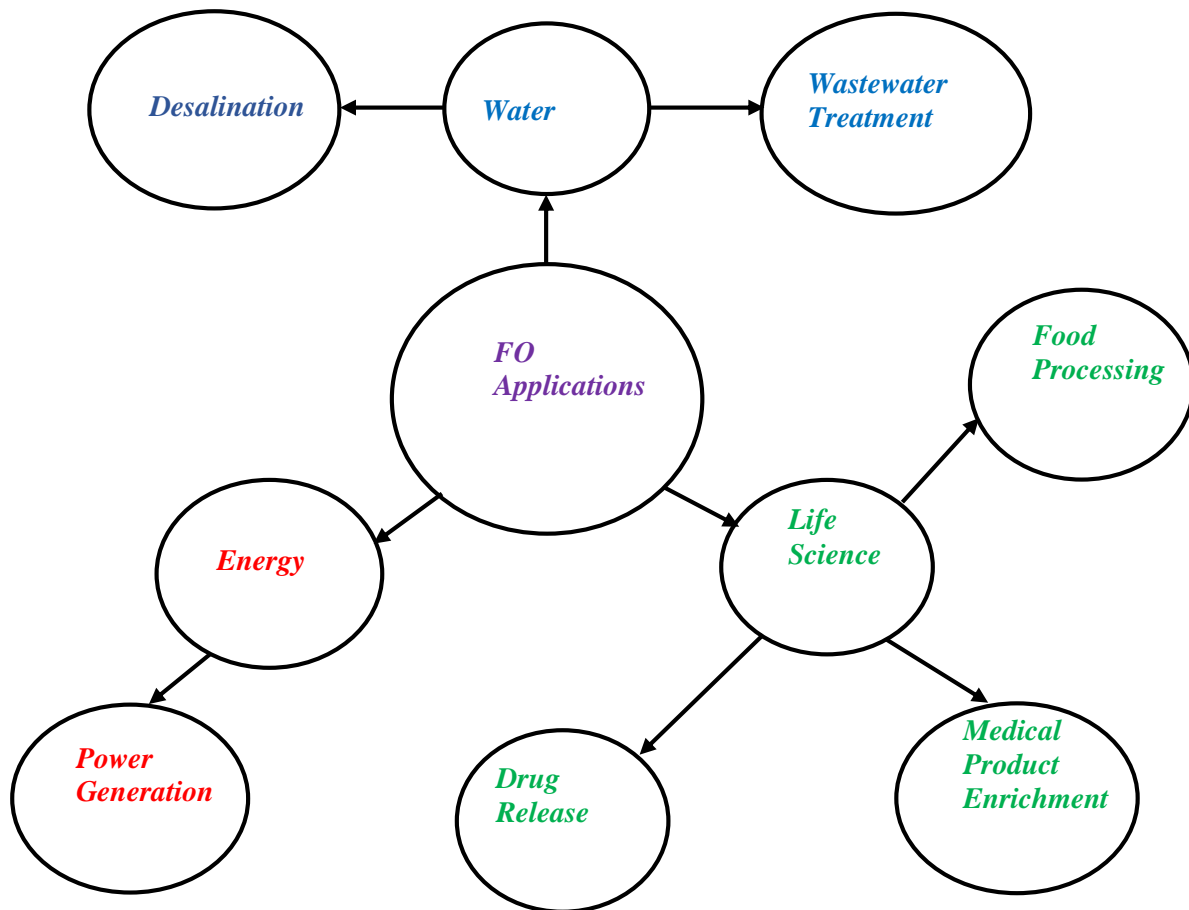

Figure 2-6:: Various applications of forward osmosis in the broad fields of power generation, waste water treatment and life science (Zhao et al., 2012)

2.3 Factors Influencing forward osmosis

In this section the following factors that influence FO are discussed: concentration polarisation; membrane fouling, draw solute back diffusion, effect of solution temperature and compound rejection by the membrane.

2.3.1 Concentration Polarisation

The diffusion of water molecules across the membrane occurs simultaneously with the advective transport of particles and solutes from the solution towards the surface of the membrane where they may be rejected. The rejection of these materials by the membrane leads to their gradual build up on or near the surface of the membrane, thereby creating an additional barrier through which the permeate water must traverse. A higher concentration of solutes builds up close to the surface of the membrane compared to the bulk fluid. The resultant concentration boundary layer is called concentration polarisation (CP) (McCutcheon et al., 2006, Tang et al., 2010).

Concentration polarisation is encountered in both hydraulic and osmotic pressure-driven processes. It causes the actual water flux to deviate from the expected water flux. Higher salt concentration on the membrane surface results in higher resistance to passage of water. In FO, this leads to a decrease in the

osmotic pressure gradient between the feed and draw solution. In FO applications both external concentration polarisation (ECP) and internal concentration polarisation (ICP) are encountered with the former occurring at the membrane surface whilst the latter within the porous structure (Yang et al., 2015).

Concentrative ECP occurs in FO when the membrane active layer faces the feed solution (AL-FS). Solutes from the bulk solution are advectively transported by water flow towards the membrane active layer which only permits water permeation. Solutes build up on the membrane surface forming a concentration boundary layer. Dilutive ICP results due to the draw solution dilution by the permeate water. Concentrative ICP and dilutive ECP occur when the membrane is operated in the active layer facing the draw solution (AL-DS) mode. Concentrative ICP occurs when the feed solution faces the porous layer resulting in an increase of solute concentration inside the pores of this layer.

ICP is more pronounced in FO, so influencing flux to a greater extent compared to ECP (Yang et al., 2015). ~~Figure 2-7~~ ~~Figure 2-7~~ depicts the two forms of ICP which dominate depending on the membrane orientation. Gao et al. (2014) state that ECP can be mitigated by increasing flow the on surface of the membrane. Since ICP is confined to the porous substructure of the membrane, it is not possible to limit it by turbulence.

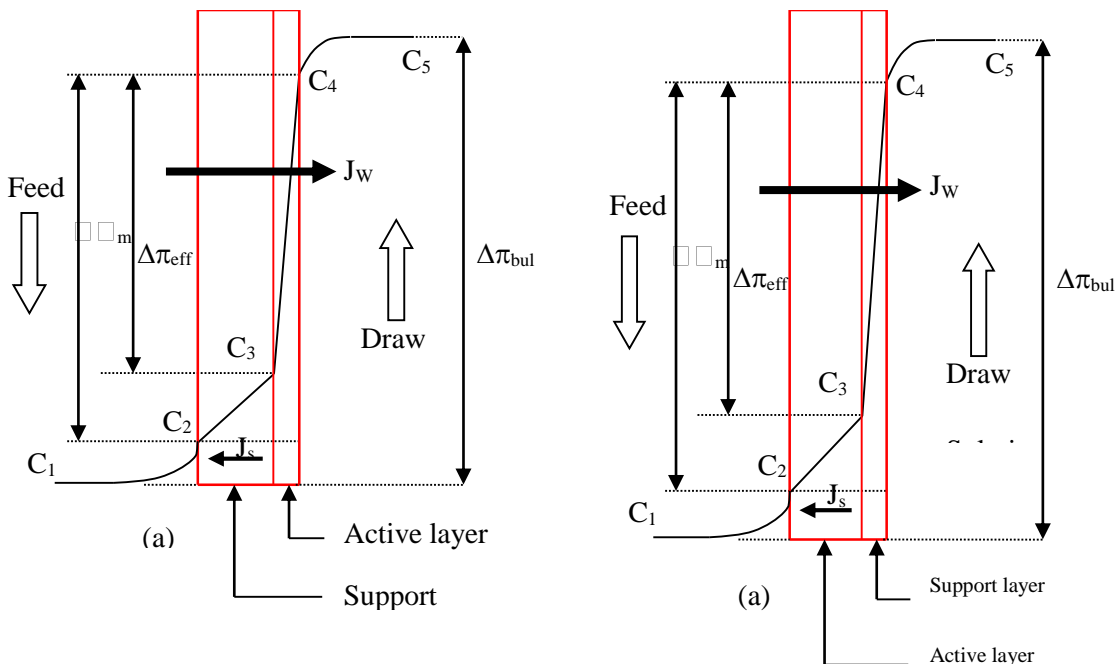

Figure 2-7::(a) Concentrative internal concentration polarisation (ICP)

(b) Dilutive internal CP across a composite or asymmetric membrane in forward osmosis.

2.3.2 Membrane Fouling

All membrane separation processes are susceptible to fouling. The International Union of Pure and Applied Chemistry (IUPAC) states that fouling is: “the process that results in a decrease in the performance of a membrane, caused by the deposition of suspended or dissolved substances on the

external membrane surface, on the membrane pores, or within the membrane pores” (IUPAC Recommendation,1996). Fouling leads to the decrease of permeate fluxes, the increase of the pressure to apply and, in severe cases, the irreversible damage of the membrane. Fouling can then impact on the membrane process separation efficiency, and increase energy consumption and operational costs.

A number of mechanisms are behind the fouling process. As illustrated in Figure 2-8, these mechanisms include: blockage of membrane pores by solutes, cake layer formation by the rejected solutes, gelation or precipitation of inorganic and organic solutes due to high concentrations that builds near the membrane solution interface and biofouling by the unwanted absorption and growth of microorganisms and their microbial products. Adsorption also occurs which decreases the porosity of the membrane.

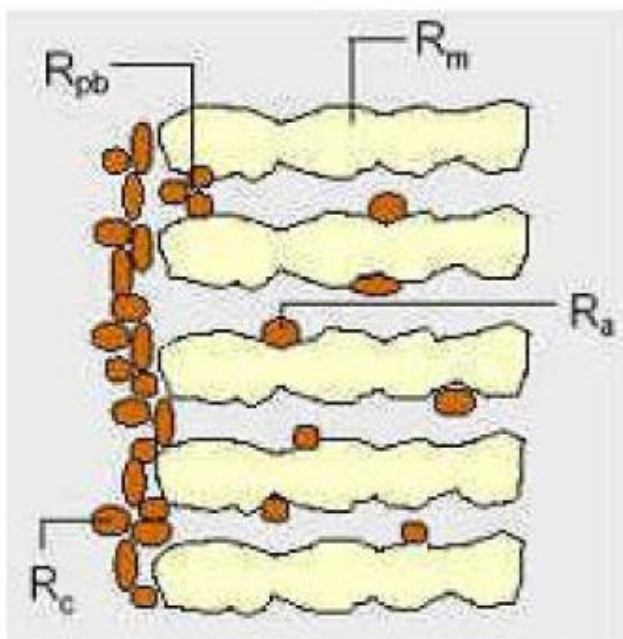

Figure 2-8:Membrane fouling mechanisms showing biofouling (R_a), pore blocking (R_{pb}), cake layer (R_c) and membrane resistance (R_m) (Wang et al., 2010)

The following aspects have been quoted in the literature concerning membrane fouling in FO membranes:

- Low fouling propensity compared to RO /NF (Mi and Elimelech, 2008, Holloway et al., 2007).
- Reversible fouling is the most likely to occur and so membrane cleaning can be implemented for flux recovery (Mi and Elimelech, 2010) .
- Fouling is significantly affected by the membrane orientation. Wang et al. (2010) reported that if the thin selective layer faces the solution to filter less fouling occurred than if the porous backing layer faced the solution to filter. In the latter case, severe internal clogging is caused by foulants that access the membrane porous support layer, leading to reduced porosity and consequently to reduced mass transfer.

- The type of draw solutes (e.g. Ca^{2+} and Mg^{2+}) are an important factor for fouling. Draw solutes back diffusion to the feed solution can cause fouling as they can precipitate or complex with organic material or alginate (e.g. Ca^{2+} and Mg^{2+}) (Zou et al., 2011).
- Initial draw solution concentration has an effect on membrane fouling (Xu et al., 2010). At higher draw solution concentrations, the more important permeate flux drag results in the formation of a more compact fouling layer.

Rinsing the membrane with deionised water and harsh chemicals can be used to clean membranes. Membrane cleaning is necessary to ensure removal of foulants on the membrane surface (Kim and DiGiano, 2009). Membrane cleaning falls into two broad categories, which are physical and chemical cleaning means. Physical cleaning employs hydraulic, pneumatic, mechanic and applied electric fields methods, whilst chemical cleaning uses chemicals like bases, oxidants, surfactants and acids (Lin et al., 2010). Both physical and chemical cleaning can be combined to fully mitigate the effects of fouling. Lin et al. (2010) provided a detailed review of the various membrane cleaning processes.

A widely used physical membrane cleaning technique is osmotic backwashing. The use of this method in FO was introduced by Spiegler and Macleish (1981). During the osmotic backwashing, deionised (DI) water replaces the draw solution, which results in an opposite direction osmotic pressure gradient as illustrated in Figure 2-9. The DI water flows then through the draw side channels towards the feed solution side, creating an opposite flow with respect to the usual operation. This may lead to the possible detachment of foulants on the membrane surface. Kim et al. (2012) carried out a study in which osmotic backwashing was applied and evaluated to control organic and particulate fouling in FO membrane process. They demonstrated that osmotic backwashing was able to effectively restore the flux, but complete flux recovery could not be achieved. The authors concluded that the duration and time interval needed optimisation to increase the efficiency of the osmotic backwashing.

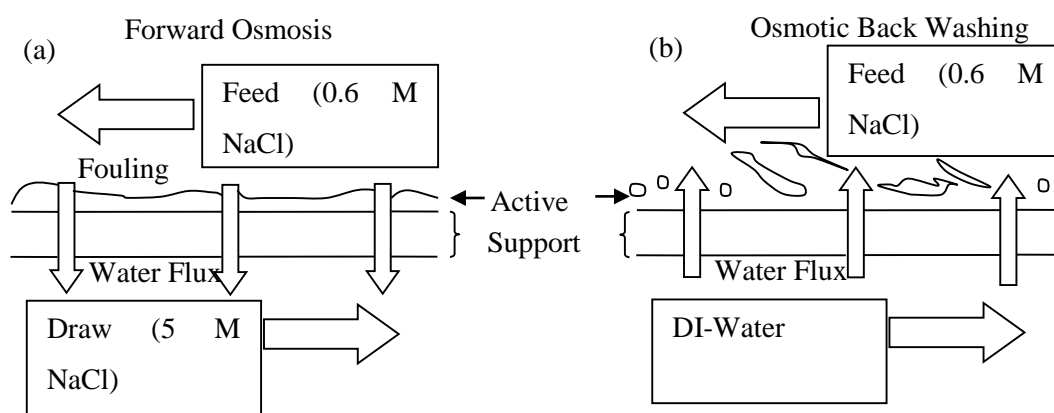

Figure 2-9:(a) Normal operation configuration (permeate flow from feed side to draw side) ;(b) Osmotic backwashing configuration (DI water flow from draw side to feed side) (Kim et al., 2012).

2.3.3 Reverse draw solute diffusion

In an attempt to better understand the movement of solutes to the feed side from the draw solution (reverse diffusion), Phillip et al. (2010) investigated the specific reverse solute flux, which is defined as the ratio of reverse solute flux to the water flux. The authors concluded that specific reverse solute flux was considerably influenced by the active layer of the membrane. The performance of the process can be bettered by improving the selectivity of the active layer so as to reduce solute diffusion (Hancock and Cath, 2009). The use of multivalent ions to constitute the draw solution was also identified as a way of mitigating reverse salt diffusion. Multivalent ions have increased radius and lower diffusion coefficients making them suitable in applications where high rejections are desired. Once solutes have back diffused they have the potential to associate with feed solutes in promoting fouling. However, Zou et al. (2011), emphasised that multivalent ions, owing to their larger ionic radius and lower diffusion coefficients may lead to severe CP. If not checked, reverse salt diffusion can result in enhanced permeate flux decline thus compromising the integrity of the FO process.

2.3.4 Effect of solution temperature and draw solution concentration on water flux

Osmotic pressure, mass transfer, mineral solubility and fluid viscosity are some of the parameters that are temperature dependent in the FO process. Increasing operating temperature generally results in higher water recoveries and consequently higher concentration factors in the feed solution (Jackson, 2014). Zhao and Zou (2011) observed that initial water flux peaked from 13 L/m².h to 17 L/m².h with a 20 °C increase in temperature with Na₂SO₄ as draw solution and brackish water as the feed solution. The authors stated that high temperatures lowered CP and the viscosity of the solutions whilst simultaneously increasing the permeability and mass transfer coefficient. However, the increase of temperature also has negative side effects, as it enhances scaling. The increase of 20 °C resulted in increased water recoveries from 91.9 % to 97.0 %, which led to an increase of the saturation degree of the feed solution resulting in severe membrane scaling.. Several authors have reported similar observations (Jawor and Hoek, 2009, Goosen et al., 2002, Jin et al., 2009, Agashichev, 2005). The above observations from literature call for the selection of an optimal temperature where water recovery will be maximized and scaling minimized.

The impact of draw solution salinity on water recovery ,water flux, and fouling propensity has been reported in literature (Holloway et al., 2007, Chung et al., 2012, McCutcheon et al., 2006). Generally, increasing draw solution concentration results in higher permeate flux and water recovery, due to the increased driving force differential between the two solutions. However, higher permeate flux can drag the solutes and particulates from the feed stream towards the membrane surface. When the solutes and particulates reach the membrane, the majority are rejected, leading to the build-up of compounds on the membrane surface creating a barrier to water permeation.

2.3.5 Species rejection

Membrane rejection is governed by a number of factors that include membrane orientation, pH, solute concentration, temperature, and fouling. Alturki et al. (2013) reported lower rejections of charged and smaller molecular weight trace organic contaminants when the membrane was operated in the active layer facing draw solution (AL-DS) mode compared to the active layer facing feed solution (AL-FS) mode. Valladares Linares et al., (2011) also alluded to the same rejection phenomenon with arsenate, boron and calcium. The observed lower rejections in the AL-DS mode were attributed to the concentrative ICP effect which resulted in an increased concentration gradient of solutes across the membrane's ultra-thin skin layer leading to lower rejections.

Feed solution pH has an influence on the charge density and the subsequent speciation of multivalent compounds thus affecting electrostatic interactions (Valladares Linares et al., 2011). The comprehensive study of Alturki et al. (2013) concluded that the rejection of ionic compounds in FO processes, is also influenced by steric hindrance, electrostatic hindrance and size exclusion. This conclusion was motivated by the high rejections associated with increased molecular weight of the ionic compounds.

Fouling has been found to affect membrane rejections of organic compounds via the following mechanisms: transformation of the charge on the membrane's surface (Xu et al., 2006, Plakas et al., 2006), blocking of membrane pores Nghiem and Hawkes (2007), or cake enhanced concentration polarisation (Ng and Elimelech, 2004, Vogel et al., 2010). Therefore, fouling is capable of increasing or decreasing membrane rejection. Valladares Linares et al., (2011) postulated that the foulant layer changed the hydrophobicity and charge on the membrane surface thus influencing the rejection of multivalent and uncharged organic compounds. Nguyen et al. (2013) explained that FO membrane rejection involves a series of complex mechanisms that include: electrostatic repulsion, steric hindrance, and both hydrophilic and hydrophobic interactions

The rejection of compounds by TFC membranes has been studied extensively in literature. Different feed streams were tested, some composed of trace organic compounds (Coday et al., 2014, Jackson, 2014), others of nutrients such as nitrogen, carbon and phosphorous (Chen et al., 2014, Nguyen et al., 2013, Hancock et al., 2013, Jackson, 2014). Coday et al. (2014) stated that the rejections of more than 70 trace organic compounds were tested under various conditions and average values above 90 % were obtained by the different FO membranes.

2.4 Investigations on the use of FO for urine treatment

Recovering water from urine using FO was studied at first by the National Aeronautics and Space Administration (NASA), Gormly and Flynn (2007). The research was informed by the need to recycle metabolic secretions, such as sweat and urine, into potable water, which will allow reduction of the

mass and volume of liquid to transport during the space missions (Flynn et al., 2012). A solution composed of KCl was used to simulate urine and a concentrated sugar solution was used as the draw solution. NASA reported that the process achieved rejections higher than 90 % for salts, higher than 85 % for the Total Oxidizable Carbon (TOC), higher than 95 % for the total nitrogen and higher than 93 % for the urea. It is important to note that these high rejections were achieved when FO was coupled with a granular activated carbon filter to pre-treat the urine before sending it into the FO rig. The membrane showed a microbial disinfecting ability with the rejection of 99.9 % of the bacterial population presented in the urine. With regards to water recovery, the membrane was able to recover 0.9 L of liquid product from 1 L of urine in 4-6 h at 25 °C.

The success of FO was followed by the assessment of the process to apply during extended cave explorations (Borer et al., 2014). The authors used the same membrane type used by NASA and changed the draw solution from a sugar solution to a NaCl solution. The authors could concentrate and reduce the volume of the urine using FO (Borer et al., 2014). In this setup, urine was directly obtained from contributors, without a pre-filtration module as there were no chances of faecal contamination. The rejections were closer to those found by the NASA (Borer et al., 2014).

Zhang et al. (2014) investigated the feasibility of FO process for nutrient recovery from simulated hydrolysed source separated urine using the recipe suggested by Griffith et al. (1976). An equivalent amount of ammonium bicarbonate was used to mimic the hydrolysed urea in stored urine. Sea water was employed as a draw solution. Cellulose tri-acetate (CTA) was selected as the material for the membrane. The rejections were obtained with the membrane operated in the AL-FS mode. Rejections of ammonium, ranging between 50-80 %, were obtained for synthetic hydrolysed urine as the feed. Rejections of potassium and phosphate were higher than 90 %, for both fresh and hydrolysed urine. Urea rejection in the fresh urine was less than 40 % which limits the application of these membranes for fresh urine concentrating. Water fluxes (20 L/m².h) were obtained during the experiments, and around 50-60 % of water from urine was recovered, which is equivalent to a concentration factor between 2.5-6. The authors suggested that reversible membrane fouling could be reduced by removing the precipitates in the synthetic hydrolysed urine prior to undertaking FO experiments. The use of weak acids was recommended for the removal of the precipitates from the membrane surface. Zhang et al. (2014) concluded that the FO process is a promising low-cost alternative for the recovery of nutrients from urine. The authors strongly recommended the performance of a Life Cycle Analysis in order to assess the environmental burden at pilot and full scale operation.

2.5 Summary

The RTTC's aim is to provide sustainable sanitation solutions to developing communities which lack access to proper sanitation, through harnessing of energy and nutrients from the faecal streams. The envisioned Reinvented toilet facility should be off grid, energy positive and should be suitable for in-

house installation. Urine provides a good source for both nutrients for agricultural use and re-usable water if sustainable separation can be properly effected.

Harvesting nitrogen, potassium, sulphur and phosphorous from urine in a sustainable manner allows the use of these nutrients as fertiliser in agriculture thus reducing the use of synthetic fertilizers whose use contributes to environmental pollution. UDDT toilets, in addition to urinals provide a convenient source of urine as the urinal stream is separated from faecal material. Once urine leaves the human body, bacteria induced breakdown/hydrolysis of urea begins which results in the formation of ammonia. The increased pH results in the precipitation of struvite and associated calcium precipitates. These precipitates pose a challenge in the treatment and processing of urine as they clog pipes. These precipitates can also limit the efficiency of further downstream processes in the recovery of nutrients from urine. Cost of nutrient harvesting is therefore increased by the need to pre-treat the urine to enable initial removal of these precipitates.

Both thermal and membrane desalination processes can be utilised in the processing of urine. Processes that have been utilised in literature in the processing of urine include: struvite precipitation, solar evaporation ,ammonia stripping and distillation (section 2.1.2).The applicability of membrane filtration process such as (UF, MF, NF and RO) in the harvesting of nutrients from urine depends on their fouling propensity, energy and operational costs and the ease of scale-up of the process. Typical stored urine osmotic pressure, conductivity and pH are summarised in [Table 2-1](#)~~Table 2-1~~.The osmotic pressure of urine is high thus nullifying the applicability of RO as separation technique. High pressure, above the osmotic pressure of urine will be required to effect separation using RO and this would increase separation costs. The presence of Ca^{2+} and Mg^{2+} in the stored urine feed stream can aggravate fouling through complexing with organic macromolecules. However, the amount of Ca^{2+} should exceed 40 mg/L to cause considerable fouling (Zou et al., 2011). The presence of magnesium and calcium related precipitates also make RO an unlikely separation technique.

The RTTC objectives call for a membrane separation technology that is cost effective, easy to scale up and off –grid and this points to FO as a possible technology to investigate to effect the separation. The draw solution should satisfy the ideal draw solution criteria as mentioned in section 2.2.4. Additionally, the constituents of the ammonium bicarbonate draw solution that is carbon dioxide and ammonia are also present in the hydrolysed urine and these can be harnessed and used to reconstitute the draw solution in a futuristic toilet. However, as alluded to by (Hancock and Cath (2009)) ,ammonium bicarbonate has a tendency to back diffuse and this can reduce the operational sustainability of the FO process .The authors reported that ammonium bicarbonate draw solution loss in FO process utilising FO- CTA membrane could range between 6-8 g/L of permeate water.

The TFC membrane pioneered by Hydration Technology Inc. has a dense ultra-thin selective layer for maximum solute rejection and to minimise solute back diffusion and the spongy porous support layer

to maximise water flux and reduce ICP. Most importantly, the TFC membrane's wide pH range of between 2-11 accommodates the pH of the urine feed stock and the ammonium bicarbonate draw solution without the need for a pH correction. A lower fouling propensity and easy of cleaning for the TFC membrane made it a membrane of choice for this project.

NASA started the idea of harvesting nutrients and water from urine, followed by cave explorers and recently Zhang et al. (2014) and Co-workers. However, it must be emphasised that NASA started with synthetic recipes that mimicked real urine and they moved to utilise fresh urine. The cave explores also harvested water from fresh urine. Zhang et al. (2014), stabilised fresh urine as described in section 2.1.1. The above investigations in literature points out to a lack of information and experiences in FO with real, stored urine. Stored urine, as argued in section 1.1, is most likely to be encountered whenever one expects to harvest water and nutrients from urine. The author of this thesis felt that this gap in literature needed addressing with regards to the challenges and behaviour associated with utilising FO in treating stored urine. To the author's knowledge, there is no work cited in literature where ammonium bicarbonate has been utilised as a draw solution with stored urine as the feed solution in a FO setup despite its advantages enumerated in section 2.2.4. The fouling tendencies of TFC membranes with urine as feed and ammonium bicarbonate as the draw solutions will also inform researchers and practitioners on its suitability depending on the characteristics of the feed stream. This study will also characterise rejections of the feed stream nutrients (N, P and K) therefore quantifying what amounts are recoverable of these nutrients from the urine feed stream. Reusable water recoverable will also be quantifiable. All this information will assist in scaling the futuristic toilet and help other practitioners within the RTTC field.

The laboratory FO rig used by several authors in literature has the same architecture as discussed in section 3.2. The variations in the basic set up come in the maintenance of the draw solution and the type of the membrane utilised for the particular investigation. Maintenance of the starting concentrations of both the feed and draw solution can be facilitated by addition of reservoir tanks for the respective solutions. In instances, where costs can be limiting, the draw and feed solution can be run without re-concentrating them and this fits well with objectives of the RTTC.

3 MATERIALS AND METHODS

This section describes the feedstock (stored urine) and draw solution (ammonium bicarbonate) utilised in this study, the laboratory FO set-up, analytical equipment, sampling procedure, chemical analysis, experimental protocol and formulae utilised to determine the parameters to evaluate FO performance. The section concludes with steps followed in the evaluation of membrane fouling.

3.1 Feedstock and Draw Solution

Stored urine was used in this study as the feedstock. The urine is collected from Urine Diverting Dry Toilet (UDDT) in the EThekweni Municipality in Durban, South Africa. It is stored in tanks located at the Newlands KwaMashu Research Centre. The Total Suspended Solids (TSS) measurement was done before and after forward osmosis on the stored urine to test the membrane's ability to reject suspended solids. A measured volume of the sample was vacuum filtered through a dried pre-weighed 110 mm diameter glass fiber filter. The filter with the residue on it was dried in an oven at 103-105 °C for 30 minutes. The total suspended solids content was indicated by the additional weight of the filter. Prior to some experiments, the centrifuged urine was diluted with deionized water by a dilution factor of 3 and 6 to take into consideration different water content of urine from flushed urinals.

In all the forward osmosis experiments conducted in this thesis, all the chemicals used were of analytical grade). 21 g/L sodium chloride was used to simulate the urine during the baseline performance test. The draw solution was prepared using analytical grade ammonium bicarbonate. NH_4HCO_3 was selected for its high water solubility and its ability to generate osmotic pressures of at least 50 bars. Upon heating above 60 °C, NH_4HCO_3 easily decomposes into carbon dioxide and gaseous ammonia allowing easy separation of the diluted draw solution. Respective mass of ammonium bicarbonate was weighed and dissolved in deionized water to prepare 0.6;1;2;2.2 and 2.5 M draw solution concentrations.

3.2 Forward osmosis setup

The bench – scale FO system, housed in the Pollution Research Group (PRG) laboratories used in this work had a membrane permeation unit (SEPA cell), a system for water circulation, and a data acquisition system. The SEPA cell's symmetrical flow channels allowed tangential flow of both solutions (draw and feed) across the membrane. The SEPA cell is shown in [Figure 3-1](#). The TFC-ES FO membrane coupon with an effective filtration area of 140 cm² was placed in the SEPA cell. The SEPA cell has the following channel dimensions: 95.25 mm channel width and 1.91 mm channel depth. The complete experimental system is shown in [Figure 3-2](#).

Control of the temperature of both the feed and draw solution tanks was achieved by the circulation of water from a temperature regulated bath, into stainless steel coils placed in the beakers containing the solutions. The two graduated beakers were completely sealed to minimize ammonia loss by evaporation

into the atmosphere. Both the feed and draw solution were continuously mixed with a magnetic stirrer to maintain the homogeneity of the solution. Two peristaltic pumps were used to circulate the feed and draw solutions between their respective feed tanks and the FO membrane cell. The process was operated in batch mode with starting volumes of the feed and draw solution tanks not being replenished. The flowrates were monitored during operation using two rotameters, which were installed on the suction side of the pumps.



Figure 3-1: Photograph of the FO membrane cell depicting the surface on which the TFC-ES FO membrane sheet is placed. The flow channels of the SEPA cell are also visible on the photograph

The rotameters and pumps were previously calibrated. The mass of the feed solution was recorded on a Kern mass balance connected to the data logging computer. Volume changes of the draw and feed solutions were monitored by noting the volume graduations on the side of the draw and feed solution tanks respectively. The volume graduations were used as check to compare the readings from the balance and that indicated by the graduations in determining the amount of water transferred across the membrane.

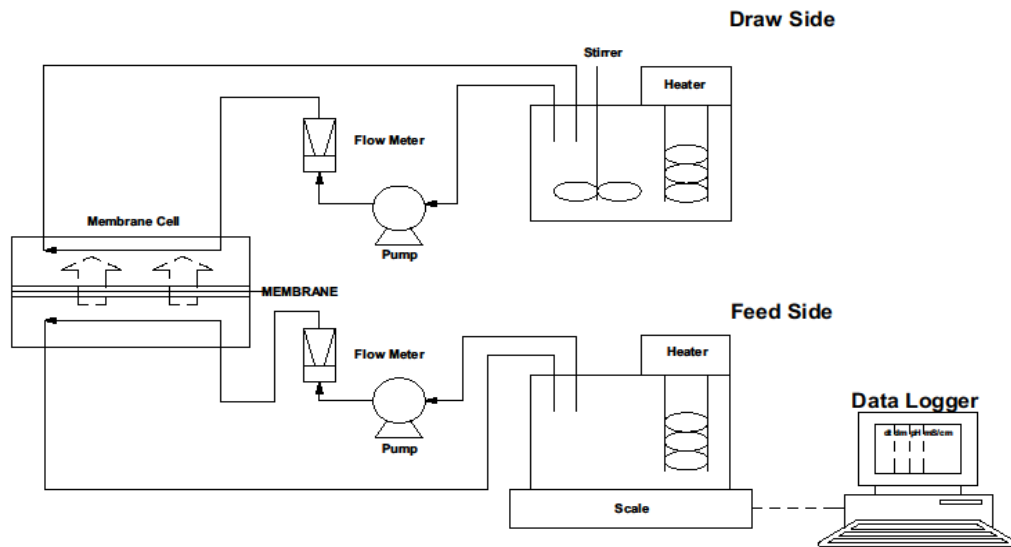

Figure 3-2: Schematic diagram of the FO setup indicating the set –up of the various units of the FO rig

A data acquisition system, LabVIEW, was employed to record the mass of the feed solution, the conductivity of the feed solution and the pH of the draw solution and continuously log the data during the filtration experiment. Data was logged on every 3 minutes of operation. The schematic drawing of the FO rig is shown in [Figure 3-2](#). Fig 3-3 shows the photograph of the laboratory set-up.

The operation of the FO rig was carried out in accordance with the Standard Operating Procedure described in Appendix A. During all the experiments, the feed and draw solution flow rates were maintained at 0.5 L/min and the temperature was maintained at 22 ± 0.1 °C. Depending on the set of experiments, different draw solution concentrations were prepared.

A leak test was performed prior to each run to monitor proper operation of the system and this involved circulating deionized water between the feed and draw solution tanks.

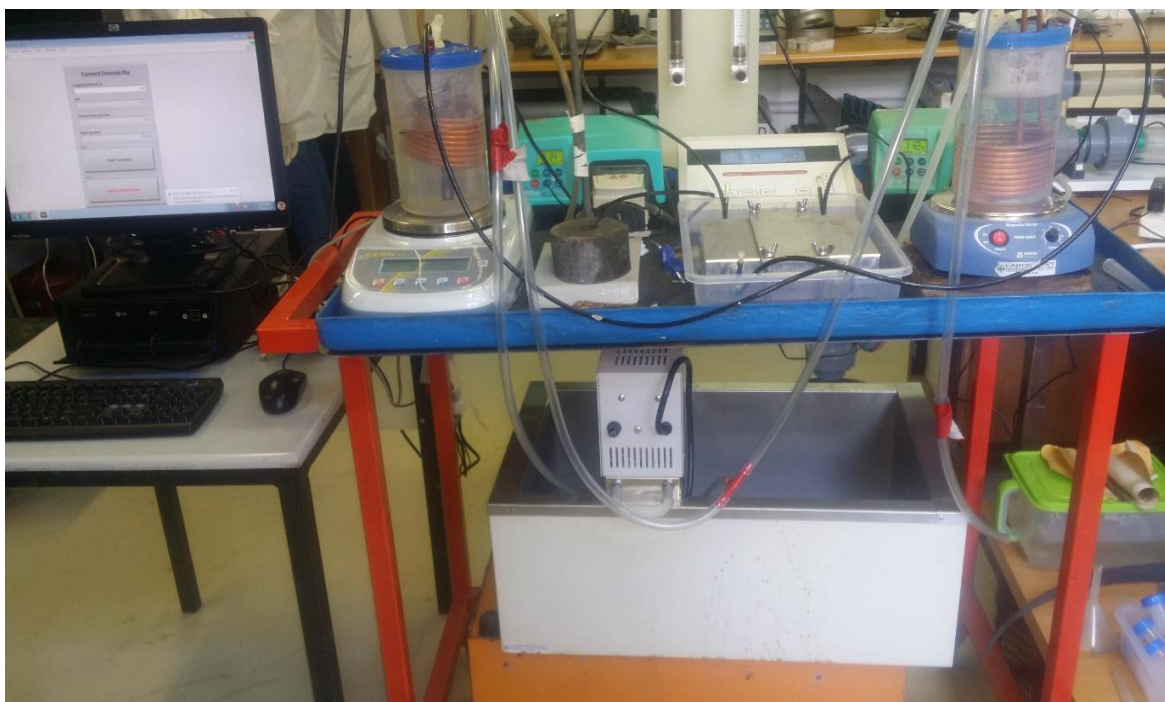

Figure 3-3: Photograph the FO laboratory rig showing the various components of the FO laboratory rig used in this study

3.3 FO Membrane

OsMem™ TFC-ES spiral-wound membranes, manufactured by Hydration Technology Innovations, were employed in this study. The membrane is comprised of a polyamide active layer placed on the top of a thick microporous polysulfone support layer. [Figure 3-4](#) shows the TFC membrane sheet placed on the SEPA cell. The membrane supports maximum operating temperature of 71°C and a maximum transmembrane pressure of 70 kPa. The pH of the solutions should be in the range of 2 to 11 and this high pH tolerance justified use of the TFC membrane. The pH tolerance of the membrane made it ideal in this study as it eliminated the need for pH adjustment. The maximum chlorine concentrations in the solutions must not exceed 0.1 ppm. Membrane sheets were immersed in deionized water before experiments as recommended by the membrane manufacturer. Refer to Appendix A for the membrane data sheet.



Figure 3-4: Flat sheet TFC-ES membrane placed on the FO membrane cell

3.4 Analytical Equipment

Table: 3-1 Analytical equipment used during experimentation.

Parameter	Instrument/Equipment	Range
pH	pH probe (<i>Hach MM150</i>).	1-14
Conductivity	Conductivity Meter (<i>Hach MM150</i>).	5-200 mS/cm
Total Suspended Solids	Oven and Analytical Balance (<i>Kern</i>)	0-1 000 g
Osmolality	Freezing Point Osmometer (<i>Gonotec</i>)	0-3 000 mOsmo/kg

3.4.1 Conductivity and pH measurements

The conductivity and pH of the urine and ammonium bicarbonate were tracked continuously by a conductivity (*Hach MM150*) and pH meter probe (*Hach MM150*). Prior to using the conductivity meter, calibration curves relating individual solute concentration in water with conductivity were conducted to facilitate the calculation of solute concentration following the measurement of conductivity during the tests. During the baseline tests, conductivity measurements during the FO runs were also used as a check of the rejection calculations of Na and Cl. During the FO runs with stored urine as the feed, conductivity readings gave an indication of the salinity of the solutions. It must be noted that, the high number of solutes in the urine made it difficult to use the conductivity method to quantify membrane rejections hence specific solutes concentrations were tracked during the runs to obtain the membrane rejections. Tracking the pH of both the feed and draw solution also gave an indication of ion movement and dominating charge on the membrane surface. The pH meter was periodically calibrated with buffers of pH of 6; 9 and 11.

3.5 Sampling

A volume of 5 mL of sample was sampled in duplicates from the feed and draw solution every 2 h from the beginning of the 8 h experiments to measure the characteristics of the streams. Samples were properly enclosed in sampling bottles to avoid contamination and loss of ammonia before analysis. Depending on the type of analysis carried out, dilutions were eventually performed to fall within the measurement range of the analyser.

3.6 Chemical Analysis

The following compounds were tracked during the FO runs: sodium (Na^+), calcium (Ca^{2+}), magnesium (Mg^{2+}), potassium (K^+), Chloride (Cl^-), total nitrogen and total phosphates. Sodium and chloride concentrations were tracked to allow the initial characterization of the membrane rejections during the baseline runs. Potassium, total phosphates and total nitrogen concentrations were monitored due to their significance as agricultural supplements. Knowing the amounts of calcium and magnesium gave an indication of precipitation that would have occurred during hydrolysis of urine. Furthermore, compounds concentrations in the feed and draw solution were analyzed during the runs to allow the performance of a mass balance and evaluation of the membrane rejections. The measured changes in the concentrations of individual ions were correlated to the volume of both tanks (feed and draw) at the time of sampling. This allowed the calculation of the mass of each ion in both solutions (feed and draw) to enable the performance of a mass balance.

The following analyzers were utilized in the determination of the concentrations of the above mentioned ions.

3.6.1 Microwave-Plasma Atomic Emission Spectroscopy (MP -AES)

The metallic cation (Na^+ , Ca^{2+} , Mg^{2+} and K^+) concentrations were analyzed using the Microwave-Plasma Atomic Emission Spectroscopy (MP -AES). Cations were tested in triplicates using Standard Method 3120 B (see Appendix A) with a maximum allowable deviation of 10 %. Standardized solutions of the above cations were made to ensure quality control. The standard and operating procedure (SOP) followed in the operation of the of the MP-AES to determine the concentrations of the above mentioned cations is presented in Appendix A

3.6.2 Chloride Analyzer 926

Chloride (Cl^-) concentration was measured by the Chloride Analyzer 926 from Sherwood. The analyser uses a coulometric titration. A constant current passed between donor electrodes helps with the accurate and quantitative generation of silver ions during the analysis. When excess silver ions are present in the solution, the sensing electrodes detect this signaling the endpoint. The equipment's characteristics are shown in [Table 3-2](#).

Table 3-2: Specifications for the Chloride Analyzer 926

Specification	Model 926
Sample size	500 μ L
Readout range	10-999 mg Cl/L
Analysis time	35 sec @ 200 mg/L
Accuracy	SD < 1 % @ 0.1 % Cl Standard solution
Linearity	1 % in range 10-999 mg Cl/L
Reproducibility CV for 20 replicates	< 1.5 % @ 200 mg Cl/L

The SOP for chloride analysis is included in Appendix A.

3.6.3 Spectroquant pharo 300

Total nitrogen and total phosphate concentrations were analyzed using the Spectroquant pharo 300 photometer from Merck. The standard operating procedure (SOP) followed in the operation of the Spectroquant pharo 300 is included in Appendix A.

3.6.4 Chemical Oxygen Demand (COD)

COD refers to the amount of organic and inorganic material in waste (urine) that is chemically oxidizable. The closed reflux method was used to measure the COD of stored urine samples. Urine samples were digested in strong acidic potassium dichromate solution for 2 h. Primary catalysis was provided by silver sulphate and mercuric sulphate acted as a masking agent to prevent chloride interference. The oxidizable material present in the urine sample partially reduces potassium dichromate. The excess potassium dichromate is titrated with ammonium iron (II) sulphate, and the total COD is calculated from the amount of titrated potassium dichromate. The equivalence colour point is indicated by the sharp colour change from blue-green to red as the ferroin indicator undergoes reduction from iron (III) to the iron (II) complex.

3.6.5 Osmotic pressure

Two approaches were used in the measurement of the osmotic pressure of the feed and draw solutions in this study. The first method involved the use of the freezing point osmometer and the second method involved the use of PHREEQ CTM software, (see Appendix B) for description of the software and its limitations).

The osmolality of sodium chloride, urine and ammonium bicarbonate draw solution were measured to determine the driving force between the feed and draw solution. No prior dilutions were required for the osmolality measurements. The osmolality of both the feed and draw solutions were measured using a freezing point osmometer, Gonotec Osmomat 3000. The osmometer operation is based on the freezing point depression method and had a measurement range of 0-3000 mosmoles/kg. Osmometer calibration was performed using NaCl standards as received from the supplier. The SOP for osmolality measurements is included in Appendix A.

3.7 Baseline determination

The preliminary part of the experimental plan was to check the basic performance of the TFC-ES membrane through the determination of the baseline. The baseline test consisted of 21 g/L NaCl as the feed and 2 M NH_4HCO_3 as the draw solution. The NaCl solution was deemed non-fouling due to its high solubility and absence of suspended solids. This test allowed the evaluation of the flux behavior without a foulant in the feed water since the feed solution was concentrated with time and the draw solution diluted with time during the FO operation. Every experimental run with urine was preceded by a baseline run. During each of the baseline runs, 21 g/L NaCl with the same osmotic pressure (15 bar) as the urine feedstock was used and 2 M NH_4HCO_3 as draw solution. The starting osmotic pressure of urine was obtained via calibration through osmolality measurements that were converted to equivalent osmotic pressures. It was assumed that the starting urine concentration is dilute to enable the conversion of osmolality into osmotic pressures. The starting osmotic pressure of NaCl was determined via concentration vs conductivity calibration. The osmotic pressure values obtained values for both ammonium bicarbonate and sodium chloride) were compared with those from literature (see Appendix B).

3.8 Determination of the parameters of the FO process

To evaluate the performance of the system, the following parameters were evaluated: water flux, reverse salt permeation, solute flux, rejection and osmotic pressure as a function of operating conditions. The following procedures were employed in investigating and calculating the parameters.

3.8.1 Determination of water flux and batch recovery

The permeation of water through the membrane from the feed to the draw side resulted in a decrease in the weight of the feed solution and an increase in the weight of the draw solution with time. The change in mass of the feed solution due to water permeation across the membrane was used to calculate the water flux, J_w (L/m².h), by using equation (3.1).

$$J_w = \frac{\Delta W}{\rho \times A \times \Delta t} \quad (3.1)$$

where

ΔW = weight of the feed solution (kg)

ρ = water density (kg/m³)

A = membrane effective filtration area (m²)

Δt = time(s)

The calculated flux, J_w , from the experimental data was corrected with respect to temperature using equation 3.2, which was provided by the manufacturer of the membrane.

$$J_w(T) = J_w \times \exp\left(-522.9 \times \frac{1}{25 + 125.64} - \frac{1}{T + 125.64}\right) \quad (3.2)$$

where

T = temperature in (K)

Upon completion of each experiment, the overall permeate volume (calculated from the total weight change of the feed or draw solution) was divided by the initial volume of the solution to obtain the batch recovery given by the following equation 3.3:

$$R = \frac{V_p}{V_F} \times 100 \% \quad (3.3)$$

R = batch recovery of the FO process, %

V_p = overall volume of the permeate, L

V_F = initial volume of the feed solution, L

3.8.2 Reverse salt permeation

To characterize the back diffusion of the draw solutes, J_s , into the feed solution, the alkalinity test was performed. For this, the feed and draw solutions alkalinities were measured at the beginning and at the end of the 8 h experiments in order to determine the quantity of bicarbonate diffused towards the feed solution. The alkalinity was deduced by measuring the amount of sulphuric acid to decrease the pH of the sample up to 4.2. The quantity of ammonium diffused towards the feed solution was obtained from the spectroquant tests. The alkalinity measurements were only conducted during the baseline tests. The back diffusion of ammonium bicarbonate would be difficult to measure in urine because: urine already contains considerable amounts of ammonium which can mask the ammonium back diffused and urine also contains a variety of compounds that can hinder the alkalinity test.

3.8.3 Solute flux

The solute flux, J_c , was measured to track the movement of solutes. The mass of a solute in the draw solution tank, M_{DS} , was calculated by multiplying the concentration of the contaminant in the draw stream by the total volume of the draw stream. J_c (g/m².h) was calculated using equation (3.4), where A (m²) is the effective membrane area and Δt (h) is the change in time between sampling.

$$J_c = \frac{\Delta M_{DS}}{A \times \Delta t} \quad (3.4)$$

where

J_c = solute flux (g/m².h)

ΔM_{DS} = solute mass in draw solution(g)

A = membrane effective filtration area (m²)

Δt = time(s)

3.8.4 Rejection

Membrane rejections were evaluated to understand the suitability of a TFC membrane as a barrier to the feed nutrients in the stored urine. The rejections of the different compounds were calculated by measuring the concentration in the feed and the permeate tanks after every 2 h during the 8 h runs. Equation 3.4 represents the general equation for calculating membrane rejection

$$R(\%) = \left(1 - \frac{C_p}{C_f} \right) \times 100\% \quad (3.5)$$

Where

C_f = initial concentration of the compound in the feed

C_p = compound concentration in the permeate tank after 2 h

However, during the FO process, the permeate concentration of the target solute was diluted by the draw solution resulting in the overestimation of the actual membrane rejection performance. To obtain the real performance of the FO process, the actual (corrected) concentration of the target solute, $C_{s(t)}$, can be calculated by carrying out a mass balance that takes into account the dilution (Abousnina and Nghiem, 2014).

$$C_{s(t)} = \frac{C_{ds(t)}V_{ds(t)} - C_{ds(t-1)}V_{ds(t-1)}}{V_{w(t)}} \quad (3.6)$$

where

$V_{w(t)}$ = permeate volume of water to the draw solution (mL) at time t,

$V_{ds(t-1)}$ = volume of draw solution (mL) at time (t-1),

$V_{ds(t)}$ = volume of draw solution (mL) at time (t),

$C_{ds(t)}$ = concentration of target solute in the draw solution (mg/L) at time (t),

$C_{ds(t-1)}$ = measured concentration (mg/L) of the target solute in the draw solution at (t-1). Consequently, the solute rejection in the FO process is calculated using the actual (corrected) permeate concentration, yielding:

$$R_{FO} = \left(1 - \frac{C_{s(t)}}{C_{(ft)}} \right) \quad (3.7)$$

where $C_{(ft)}$ = target solute concentration in the feed at time t

Feed concentration, $C_{(ft)}$ and draw solution concentrations were measured from samples collected from the respective streams every 2 h and analyzed.

3.8.5 Osmotic pressure calculation

Two approaches were adopted in calculating the osmotic pressure. The first involved the use of the osmolality of solutions from the osmometer and the second used the activity of water which was the output from PHREEQ CTM.

The measured stored urine osmolality was converted to equivalent osmotic pressures using the Van't Hoff equation. It is important to note that it was assumed that the stored urine solutions were dilute enough to ensure applicability of the Van't Hoff equation.

$$\pi = MRT \quad (3.8)$$

Where

M = solute concentration (mol/L)

R = universal gas constant (0.08314 L bar/mol K)

T = temperature (K)

The use of PHREEQ CTM software required species concentrations as input data together with the pH and temperature of the solutions. The software yielded the activity of water which was used to calculate the osmotic pressure of the solutions using the equation below

$$\pi = -\frac{RT}{\nu} \ln(a_{H_2O}) \quad (3.9)$$

Where

v = is the partial molar volume of water (0,018067 m³/mol) at 298 Kelvins for dilute solutions

a_{H_2O} = is the activity of water

The results from the above two methods were compared to results from literature and the results are presented in Appendix B.

3.9 Membrane fouling evaluation

Two methods were evaluated to test the fouling reversibility of the TFC-ES membranes: the circulation of deionized water at higher flow rates and the utilization of an osmotic backwash.

An experimental approach proposed by Zhao and Zou (2011), was applied in order to determine the effect of fouling on the membrane. Firstly, the water flux on a new membrane, J_0 , was determined by using deionized water as the feed solution and 2 M ammonium bicarbonate as the draw solution. After using the same membrane for several FO runs with stored urine, the determination of the water flux on the used membrane, J_1 , was performed with the same procedure followed for J_0 . The difference of water flux between J_0 and J_1 indicates the extent of fouling.

Next, the membrane was cleaned by the circulation of deionized water on both sides of the FO rig for approximately 30 minutes. After membrane cleaning, the determination of the water flux on the cleaned membrane, J_2 , was conducted following the same procedure for J_0 and J_1 . The removal of fouling through membrane cleaning was then evaluated by comparing J_2 and J_0 .

3.9.1 Osmotic backwash

The effects of changing the feed solution salinity and length of an osmotic backwash were both investigated. Ammonium bicarbonate was used as the feed solution during the backwashing experiments and distilled water as the draw solution. This configuration leads to the inverse of the osmotic pressure gradient across the TFC-ES membrane. ~~Table: 3-3~~ ~~Table: 3-3~~ shows the parameters used during the osmotic backwash experiments.

Table: 3-3 Operating conditions during the osmotic backwash experiments

Test 1	Osmotic Backwash Time (min)	Feed Solution Concentration (mol /L)
1	30	1
2	60	1
3	30	2
4	60	2

Prior to the osmotic backwash, all the water trapped within the system was drained to minimize the influence of residual salts on the osmotic pressure differential across the membrane during the osmotic

backwash. Extreme caution was exercised during the draining of the system to avoid removal of foulants on the surface of the membrane. On completion of the osmotic backwash, the flux recovery was measured, in order to have an indication of the flux recovered by osmotic backwashing and compared to the previous method.

3.9.2 Scanning Electron Microscopy (SEM) Observations

Virgin and fouled membranes were observed using the scanning electron microscopy (SEM) to determine the deposition of foulants on the membrane. This analysis was coupled to energy- dispersive X- ray spectroscopy (EDX) in order to perform the chemical analysis on selected areas from the virgin and fouled membranes. Prior to the SEM observations, the forward osmosis membrane was dried at room temperature and then coated with a thin layer of platinum using an Emitech SC7620 putter coater. The SEM has a maximum resolution of 50 nm. The SEM and EDX analysis were conducted with the support of the Microanalysis Department at the University of KwaZulu Natal, Westville Campus.

4 RESULTS AND DISCUSSION

A laboratory-scale forward osmosis (FO) rig was used in order to evaluate the technical feasibility of FO for the recovery of nutrients and reusable water from stored urine. The suitability of NH_4HCO_3 as a draw solution and the use of a Thin Film Composite (TFC) membrane in the process to achieve this goal were investigated. The feed and draw solution concentrations were varied in order to determine their effect on the process. The stored urine was diluted at different degrees in order to take into consideration the different concentrations that can be encountered from different toilet facilities. Different draw solution concentrations were tested in order to evaluate the maximum and feasible drawing capacity without compromising the operational stability of the process (section 4.2). Besides water flux and recovery data at higher draw solution concentration, meaningful insight was gained with regards to concentration polarisation. The implications of concentration polarisation were described in greater detail in Chapter 2. The most suitable membrane for a urine processing application is one that can achieve complete retention of nutrients in the feed solution, with lower fouling and draw solutes back diffusion.

A mass balance was conducted as a consistency check through the tracking of volume changes and solute concentrations both in the feed and draw solution. Nutrient rejections were measured to characterize the separation performance achievable with the TFC membrane. High rejections of phosphorous, potassium and nitrogen are of interest for an agricultural application. A detailed analysis of the rejections obtained is described in section 4.3

The fouling propensity and robustness of the TFC FO membrane with stored urine as the feed stream were investigated. Scanning Electron Microscopy (SEM) and Energy Dispersive X-ray (EDX) analysis were done on the surface of a membrane before and after use, in order to identify and characterize the fouling deposits. Membrane cleaning was performed in order to mitigate the impact of fouling. The fouling removal was quantified by the measurement of the water flux after cleaning. Section 4.4 provides a detailed summary of the results obtained from the fouling investigation and plausible explanations for the observed trends.

Data fitting was done using Matlab as a consistency check of the water flux and nutrient rejections. This step was done to organise the results in a qualitative framework that can assist a variety of end-users. Depending on the intended application, the data can be extrapolated to fit different physical set-ups. This allows the reduction of experimental effort, as it gives important insight into the fundamental variables to track during the experimental work. In the envisioned future reinvented toilet, the framework will be able to handle different feed conditions to predict possible outcomes. The detailed results and major assumptions made during the data fitting are summarised in section 4.5.

In all the runs, unless stated otherwise, analysis of the data collected during the experiments revealed that the flux stabilised after 45 minutes. All the data used to analyse parameters of interest was therefore collected after 45 minutes. Statistical analysis which entailed the determination of the standard deviation was done on all the water flux and rejection data recorded.

4.1 Analysis of the feedstock

The composition of the stored urine feedstock used in this thesis is shown in [Table 4-1](#). The stored urine composition, particularly concerning total phosphates, total nitrogen, chlorides, potassium and sodium, agreed with the data reported in literature for hydrolysed urine (Kirchmann and Pettersson, 1994, Nordin et al., 2009, Meinzinger and Oldenburg, 2009, Pradhan et al., 2007, Ban and Dave, 2004, Udert et al., 2003, Udert et al., 2015, Rose et al., 2015, Vinnerås, 2001). Very low concentrations of calcium (10-11 mg/L) and magnesium (24-25 mg/L) were observed in the stored hydrolysed urine. The measured osmolality of stored urine ranged between 640-700 mOsmo/kg, which agrees with the results from Rose et al. (2015). Hydrolysed urine osmotic pressure ranged between 15-16 bars and this fell within the range reported in literature (Udert et al., 2015, Rose et al., 2015). The pH and conductivity of the stored urine ranged between 7.8-10 and 25-33 mS/cm respectively. These values were similar to those reported by (Rose et al., 2015, Kirchmann and Pettersson, 1994, Udert et al., 2015). A total suspended solids content of 323 mg/L was obtained, corresponding to 0.76 g/day/person which is close to the values reported by Jönsson et al. (2005). The COD content of the stored urine was measured at 6000 mg of O₂/L, which lies within the range specified by Rose et al. (2015).

Table 4-1: Composition of the stored urine used in this study

Parameter	Units	Stored PRG Urine(Min)	Stored PRG Urine(Max)	Stored PRG Urine(Mean)
pH		7.8	10	8
Conductivity	mS/cm	25	33	29
Total Phosphates,TP	mg/L	1770	1800	1783
Potassium	mg/L	1478	1500	1488
Magnesium, Mg	mg/L	24	25	24.5
Chloride,Cl	mg/L	3100	3300	3200
Calcium, Ca	mg/L	9	11	10
Total Nitrogen, TN	mg/L	4830	4980	4870
Total Suspended Solids(TSS)	mg/L	318	328	323

4.2 Flux analysis

This section discusses the effects of membrane orientation on water flux and solute flux obtained during the baseline analysis, evolution of flux with time, water recoveries, effect of draw solution concentration on water flux and the relationship between water flux and osmotic pressure.

4.2.1 Effect of membrane orientation on water flux and reverse solute flux

The effect of membrane orientation under the same experimental condition (stored urine as feed solution; 2M ammonium bicarbonate as draw solution; 22 ± 0.5 °C) was investigated. The water fluxes obtained for the active layer facing draw solution (AL-DS) and active layer facing feed solution (AL-FS) membrane orientation were 6.40 ± 0.1 and 3.77 ± 0.7 L/m².h respectively over a period of 4 h. Several authors (Zhao et al., 2011, McCutcheon and Elimelech, 2006, Xu et al., 2010) have attributed the difference in water flux to the different osmotic pressure difference created by different concentration polarization intensities between both membrane configuration. In the AL-FS mode, dilutive internal concentration polarisation dominates while concentrative internal polarisation occurs in the AL-DS mode. The lower water flux in the AL-FS maybe caused by the decrease of the osmotic pressure difference, resulting from the draw solution dilution by the permeate water in the membrane porous structure.

Several authors (Phillip et al., 2010, Yong et al., 2012, Xue et al., 2015) observed that reverse salt flux is higher when the membrane is operated in the AL-DS mode compared to the AL-FS mode due to the ICP effects. In order to verify this assumption, reverse solute flux was investigated by tracking the ammonium and bicarbonate ions back diffusion by using 21 g/L NaCl as feed solution and 2 M ammonium bicarbonate as the draw solution. Measurements indicated an average reverse solute flux of 4 ± 0.3 and 7.1 ± 0.1 g of ammonium bicarbonate per litre of permeated water across the membrane in the AL-FS and AL- DS mode respectively. Studies conducted by (Achilli et al., 2010, Hancock and Cath, 2009) albeit using the FO-CTA membrane operated in the AL-FS indicated an ammonium bicarbonate draw solution loss in the range between 6-8 g/L of water that permeated the membrane.

The loss of ammonium bicarbonate draw solution as it diffuses into the feed solution has to be minimised to improve the sustainability of the FO process and the subsequent treatment process. Draw solution loss leads to increase in operational costs, loss of driving force and contamination of the feed solution. In the rest of the work in this thesis, the TFC FO membrane was operated in the AL-FS mode to limit solute reverse flux.

4.2.2 Evolution of flux with time

This section shows the water flux behaviour during the 8 h filtration of stored urine with ammonium bicarbonate as the draw solution. Both the feed and draw solution were not replenished during operation. Each condition was repeated three times with new membranes and solutions. [Figure 4-1](#)~~Figure 4-1~~

shows that during the filtration process with 1 M ,2 M and 2.5 M ammonium bicarbonate as draw solution, the flux declined with time. The flux decline can be attributed to (1) membrane fouling (2) a loss of osmotic driving force across the FO membrane as the draw solution gets diluted and the feed salinity increases. These effects will be examined further in more detail in section 4.4 .

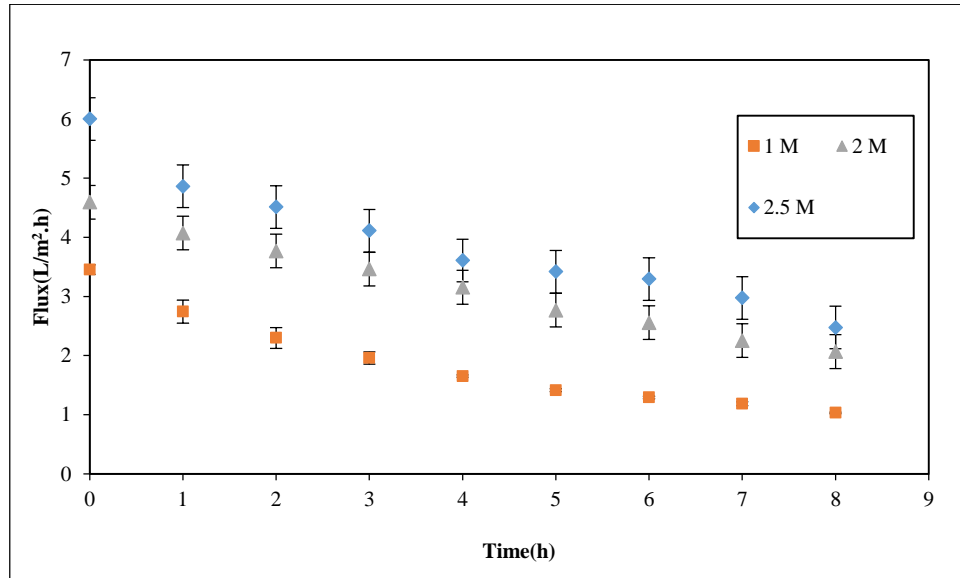

Figure 4-1: Water flux with time with stored urine as the feed solution and ammonium bicarbonate(1M,2M and 2.5) as the draw solution with the membrane operated in the AL-FS mode.

The highest water flux of 6 L/m².h was obtained with 2.5 M ,4.6 L/m².h with 2 M and 3.48 L/m².h with 1 M ammonium bicarbonate as the draw solution respectively. The differences in water flux can be explained by the higher driving forces that exist across the membrane at higher draw solution concentrations.

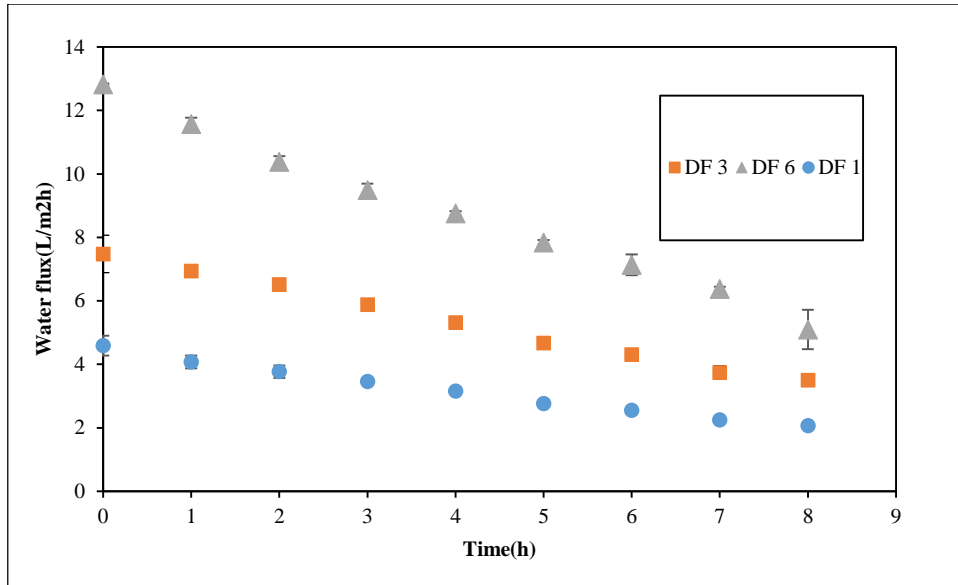

Figure 4-2: Water flux for urine feedstock at different dilution factors with 2 M ammonium bicarbonate as the draw solution with the membrane operated in the AL-FS mode. Each condition repeated three times with new membranes and solutions.

Figure 4-2 shows the water flux for three different urine solutions diluted by different dilution factors (D 1 represents undiluted urine, DF 2 represents urine diluted by a factor 2 and DF 3 represents urine diluted by a factor of 6) using the membrane in the AL-FS mode and 2 M ammonium bicarbonate as draw solution. An increase in feed solution dilution results in an increase of the water flux due to the higher osmotic pressure (driving force) difference between the feed and draw solution. The urine osmotic pressure is lowered with dilution, leading to the increase of the osmotic pressure difference between the feed and draw solution. This result points out that FO can handle urine with various dilution factors, for example from urinals where urine is mixed with flush water and still achieve high water fluxes.

4.2.3 Water Recoveries

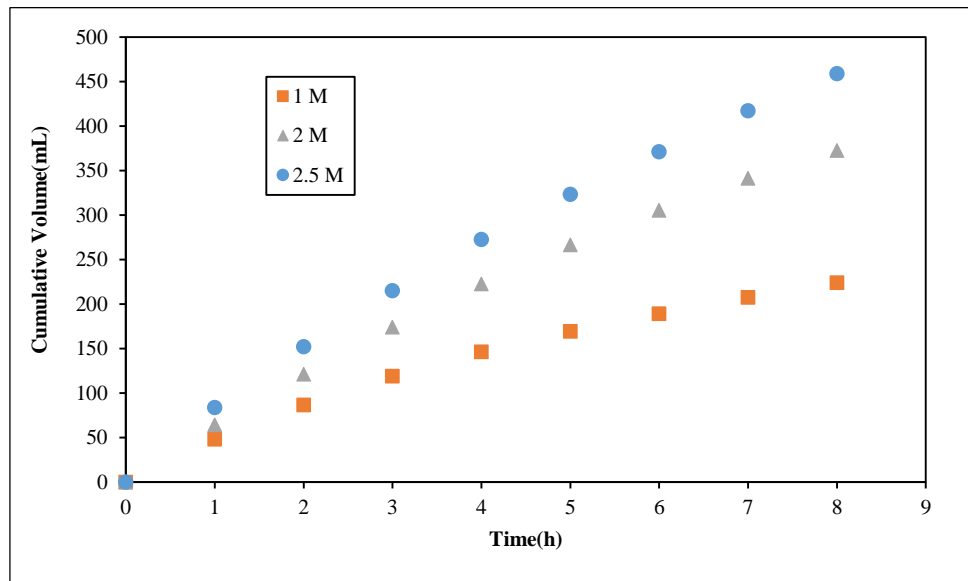

Figure 4-3: Cumulative volume as a function of time at different draw solution concentrations (1 M, 2 M and 2.5 M) with urine as the feed with the membrane operated in the AL-FS mode

The total volume of water collected during the 8 h run at each particular concentration is represented in [Figure 4-3](#) with an average of 459 mL, 372 mL and 224 mL being collected at 2.5 M, 2M and 1 M respectively. The above volumes correspond to final batch water recoveries of 45.9 %, 37.9 % and 22.4 % at 2.5 M, 2 M and 1 M draw solution concentrations respectively. The same explanation proffered in the previous section can be used to explain the observed water recoveries during the 8 h period.

4.2.4 Relationship between draw solution concentration and water flux

Since the FO runs were performed in batch configuration, the draw solution dilution resulted in flux reduction over time due to the decrease of the osmotic pressure. The water flux selected for the following analysis of the results was that obtained during the first 2 h of operation at each draw solution concentration.

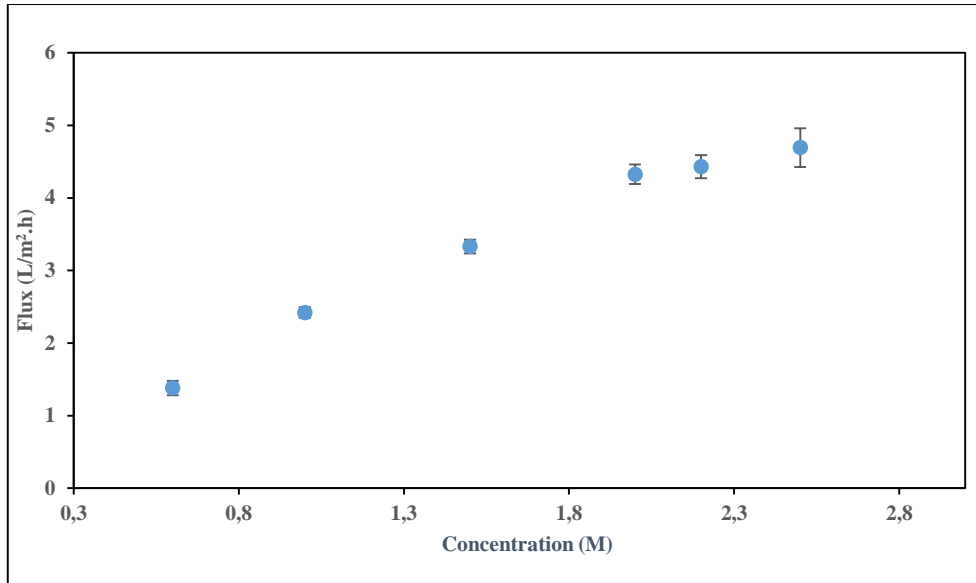

Figure 4-4: Water flux as a function of draw solution concentration for short- term bench scale forward osmosis experiments with urine as the feed solution. Experiments were conducted with feed and draw solution temperatures of 22 ± 0.1 °C and feed and draw solution flow rate of 0.5 L/min

Figure 4-4 shows the water flux obtained at different draw solution concentrations with the membrane active layer facing the urine feed solution. Water flux increased at higher draw solution concentration as a result of the increased driving force between the feed and draw solutions. According to Equation 2.6 (section 2.2.2), the increase of water flux with respect to the osmotic pressure difference should be linear. However, a non-linear trend can be seen, particularly at the higher draw solution concentrations, corresponding to the higher driving forces. The non-linearity points out to the existence of concentration polarisation and this assumption is verified in the next section.

4.2.5 Relationship between water flux and osmotic pressure

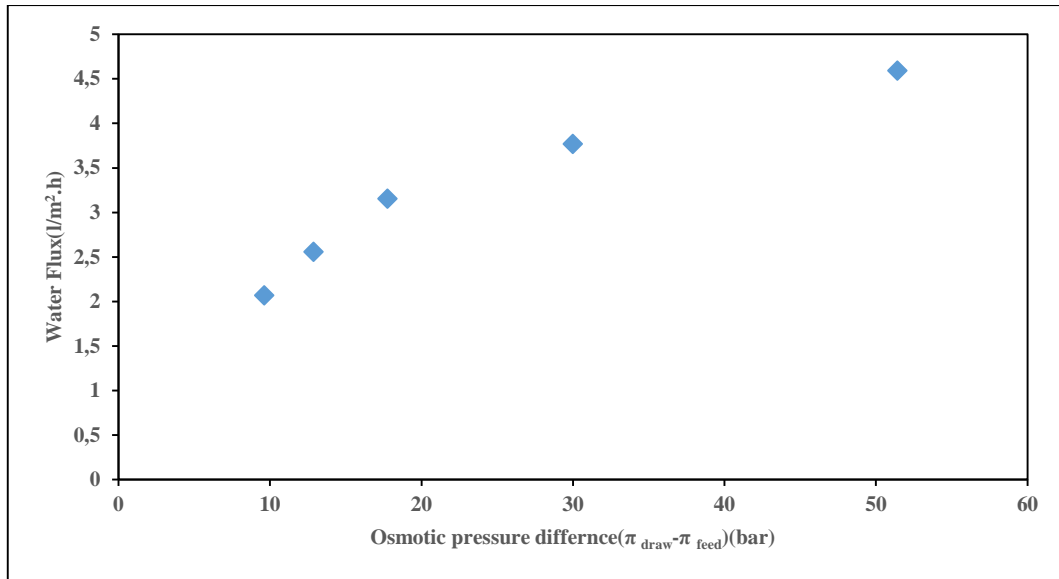

Figure 4-5: Water flux as function of the osmotic pressure difference between the feed and draw solution during an 8 h run with the membrane in the AL-FS mode and feed and draw solution flow rate 0.5 L/min and a temperature of 22 ± 0.1 °C.

The osmotic pressure difference indicates the bulk osmotic pressure difference between the feed and draw solution. [Figure 4-5](#) shows that water flux increases with an increase in the osmotic pressure difference, however, the increase is non-linear. The non-linearity can be explained by dilutive internal concentration polarisation (ICP) that occurs when an asymmetric FO membrane is operated in AL-FS mode. This phenomenon occurs when pure water that permeates the membrane from the feed solution dilutes the salt in the porous support layer of the asymmetric FO membrane. Several authors (McCutcheon et al., 2006, Yang et al., 2015, Le and Nunes, 2016) have reported this phenomena in literature.

To test the hypothesis, that the non-linearity is due to dilutive ICP, the driving force is normalised as suggested by Loeb et al. (1997). The author suggested that the ratio of draw solution to feed solution bulk osmotic pressure, $\frac{\pi_{draw}}{\pi_{feed}}$, when plotted with water flux should yield a linear curve. Loeb et al. (1997) states that the logarithm of the ratio, $\frac{\pi_{draw}}{\pi_{feed}}$, fairly represents the effective driving force in a FO process that is influenced by internal CP. Experimental data from [Figure 4-5](#) was used to test Loeb et al. (1997) hypothesis and the results are shown in [Figure 4-6](#). The linear trend confirms that the data obtained in this work agrees with the hypothesis of dilutive ICP in asymmetric FO membrane.

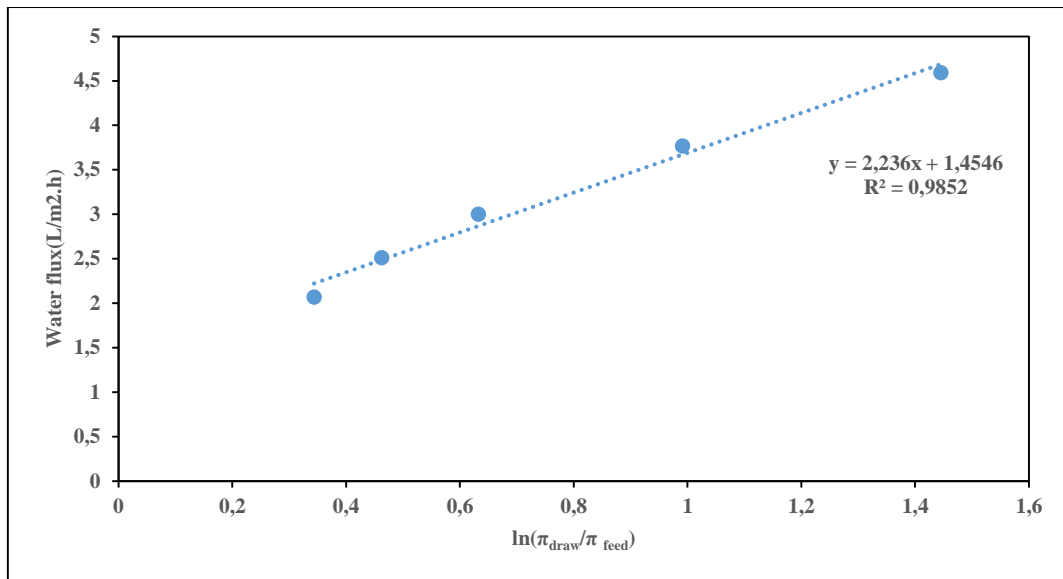

Figure 4-6: Logarithm of the ratio of bulk draw solution osmotic pressure to bulk feed solution osmotic pressure against water flux.

These results indicate that dilutive internal concentration polarisation had an effect on water flux at high driving forces during the FO of stored urine. These observations point out to the need to find an optimal draw solution concentration that gives high water flux with minimal concentration polarisation effects to minimise the diminishing return on additional driving force.

4.3 Rejections

Feed and draw solution conductivities were continuously tracked during the 8 h run to confirm dilution and concentration of the draw solution and feed solution respectively. The urine feed solution conductivity increased from 30 mS/cm to 70 mS/cm whilst the 2 M ammonium bicarbonate draw solution conductivity decreased from 117 mS/cm to 90 mS/cm indicating the respective concentration and dilution of the feed and draw solution (Appendix B). pH changes of both the draw and feed solution were also monitored to give indications of ion speciation. The pH of the feed (stored urine) varied from 8 to 11 whilst that of the draw solution showed slight variation between 7.5 and 8.1.

The investigation of nutrient rejections was performed in two steps. In the first step, 21 g/L NaCl was used as the feed solution and 2 M NH_4HCO_3 as the draw solution to get an initial understanding of the membrane rejections. In the second step, urine was used as the feed solution, with the same draw solution concentration.

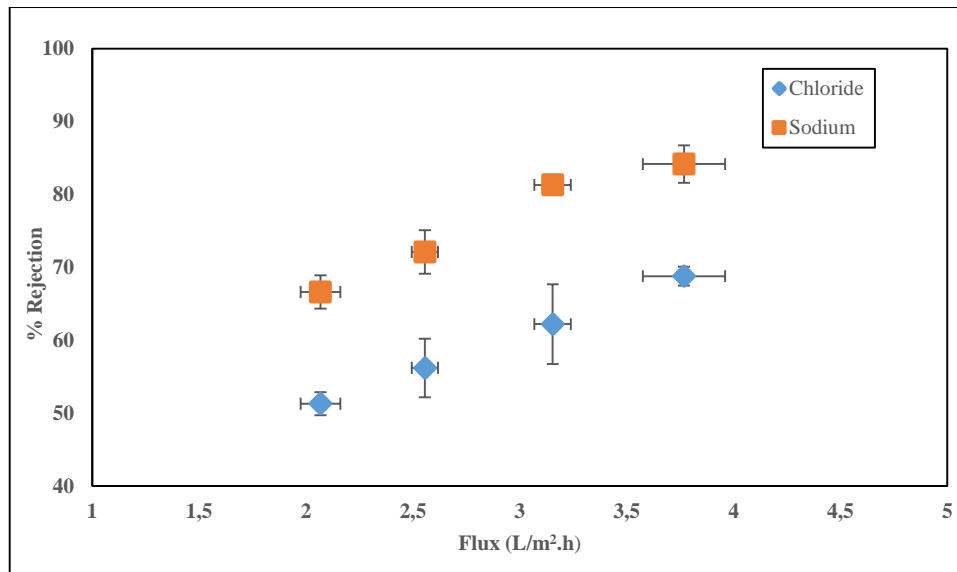

Figure 4-7: Water flux vs measured nutrient rejection during baseline testing with 21 g/L NaCl as the feed and 2 M ammonium bicarbonate as the draw solution. The membrane was operated in the AL-FS mode.

The membrane exhibited maximum sodium and chloride rejections with values of 62 % and 86% being obtained respectively during the first 2 h, with the rejections dropping to 49 and 66 % after 8 h (Figure 4-9). This trend shows that a fairly linear relationship existed between water flux and nutrient rejections for both sodium and chloride.

In this study, it was found that for every litre of water that permeated across the membrane, approximately 4 g of NH_4HCO_3 was lost to the feed solution. The diffusion of ammonium and bicarbonate ions into the feed solution could change the charge balance on the membrane. The back diffusion of negatively charged carbonate ions will make the membrane surface more negative thus increasing the electrostatic repulsion of chloride ions. The reverse diffusion of the draw solutes is one of the major draw backs associated with using ammonium bicarbonate as the draw solution (Phillip et al., 2010). ~~In the context of this work, high rejections of chloride obtained ensures the suitability of the feed concentrate as fertilizer as the negative effects of chloride on plant growths which include stunted growth, wilting and plant stress are reduced. Several authors (Lee and Van Iersel, 2008, Qados, 2011, Chinnusamy et al., 2005) have elaborated on the negative effects of high NaCl in soils and at the same time the authors alluded to its positive roles (photosynthesis, osmotic adjustment and suppression of plant diseases) in plant growth.~~

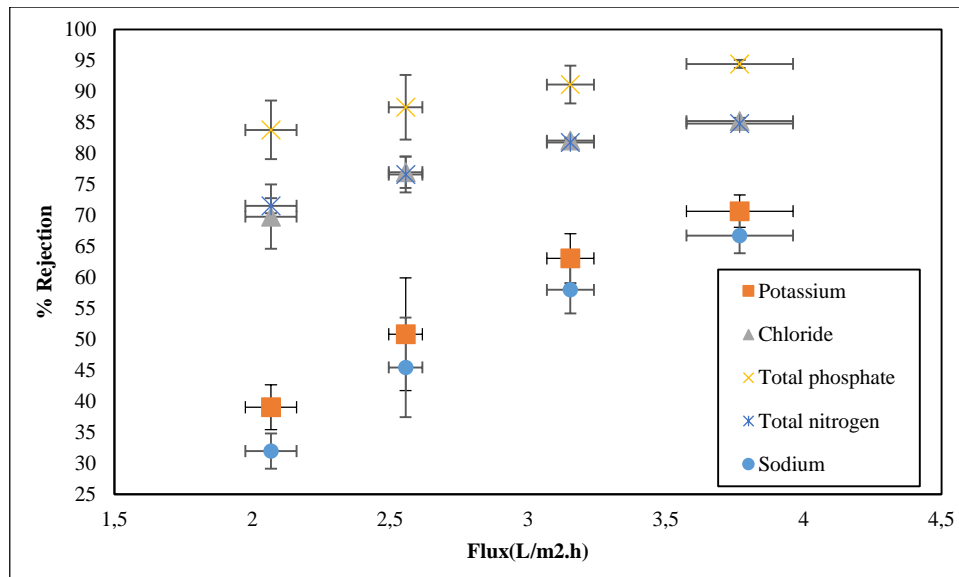

Figure 4-8: Rejections versus water flux during experiments with stored urine as feed solution

Figure 4-8 displays the nutrient rejections as function of water flux using stored urine as feedstock and 2 M as the draw solution. The TFC- FO membrane revealed fairly high rejections (> 30 %) for all the measured compounds (total phosphates, total nitrogen, potassium, chlorides and sodium). The membrane revealed high rejections of total phosphates (86-91 %) and total nitrogen (70-84 %) followed by chloride (68%-82 %), potassium (44-72 %) and sodium (30-67 %) over the 8 h run. A possible explanation for the observed high rejections for total phosphates and chloride might be their ability to retard the reverse permeation of the negatively charged carbonate ions from the draw solution. This would result in electrostatic repulsion leading to higher rejections of phosphate and chloride.

The membrane exhibited lower rejections of sodium and potassium, compared to chloride, nitrogen and total phosphate. A possible explanation for the low rejections of sodium and potassium might be the fact that the membrane might have assumed a more negative charge as the pH of the urine feed stock increased during the FO process. The increase in pH was attributed to the back diffusion of the ammonium bicarbonate draw solutes. The assumed negative charge at higher pH would have attracted more positive ions towards the membrane resulting in higher permeation rates towards the draw solution.

Total nitrogen exists predominantly as ammonium ions in the stored hydrolysed urine. Therefore, following the above proffered explanations for the observed high rejections for negative ions and low rejections for positive ions we could expect the total nitrogen rejections to be low. However, the rejections are higher than that of potassium and sodium. The observed higher rejections of total nitrogen compared to those of potassium and sodium could be attributed to the complicated ionic compositions

~~and pH of the urine solutions. This anomaly may have resulted from the complicated ionic compositions and pH of the urine solution.~~ Another plausible explanation could be the mass transfer gradient that exists between the feed and draw solutions. The draw solution (ammonium bicarbonate) contains more ammonium ions than the stored feed urine resulting in a reduced mass transfer force for ammonium diffusion from the feed to the draw solution hence the observed high rejections.

4.4 Fouling

The flux reduction caused by fouling was determined through the performance of a baseline study and the efficiency of membrane cleaning was tested. Initially, deionised water circulation on both sides of the membrane was tested as a cleaning procedure. Secondly, an osmotic backwash was carried out to determine the extent of flux recovery. Membrane fouling and cleaning have major contributions on the costs associated with FO operation.

4.4.1 Baseline study

A non-fouling feed stream of 21 g/L NaCl with the same osmotic pressure as the urine was employed for the baseline experiments. Baseline tests (Figure 4-9) were performed in order to determine the flux behaviour without the presence of foulants in the feed solution. The NaCl solution was assumed to be as non-fouling and hence no fouling contribution to the flux decline could be considered.

The effect of fouling was evaluated through the deviation of the flux curve obtained for urine with respect to the baseline. In both runs, 2 M ammonium bicarbonate was used as the draw solution.

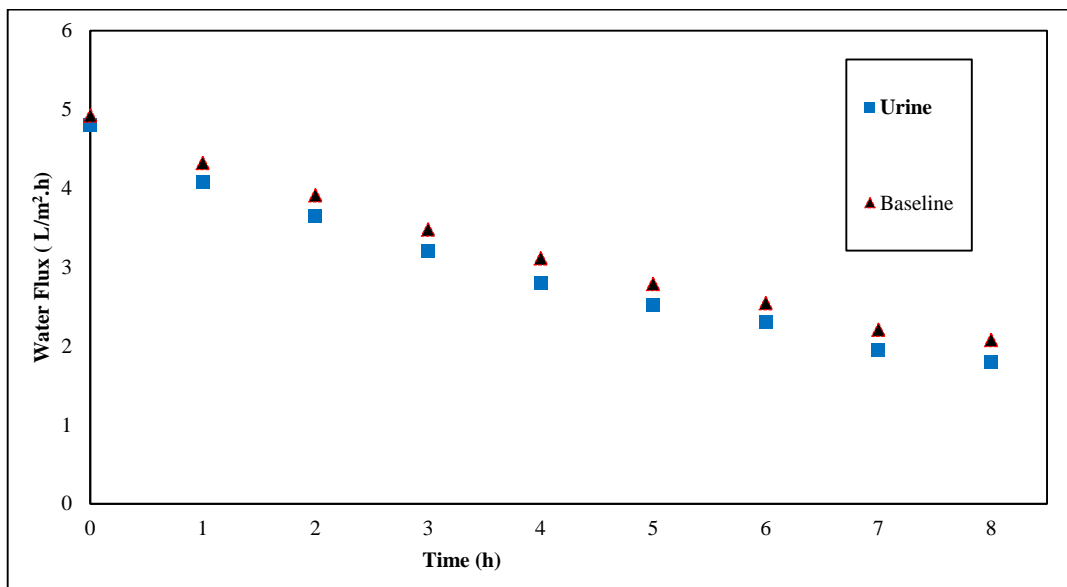

Figure 4-9: Water flux versus time during FO experiments with 2 M ammonium bicarbonate as the draw solution with the membrane operated in the AL-FS mode.

Figure 4-9 shows the water flux as a function of time during a run using urine as feedstock and for the baseline. The flux declined from a maximum value of 4.9 to 2.04 during the baseline experiment. This trend can be solely attributed to the decrease in the osmotic pressure difference between the feed and draw solution as the draw solution gets diluted and the feed solution concentrated. The flux curve for the stored urine as the feed stock is close to the baseline, with water flux declining from 4.86 to 2.04. The above observation indicates that a single FO run with stored urine as the feed causes low fouling to the TFC-ES membrane.

Figure 4-10 illustrates the fouling behaviours and cleaning effects on pure water flux in FO. The fluxes were determined with deionised water as the feed solution and 2 M ammonium bicarbonate as the draw solution during the 2 hour runs.

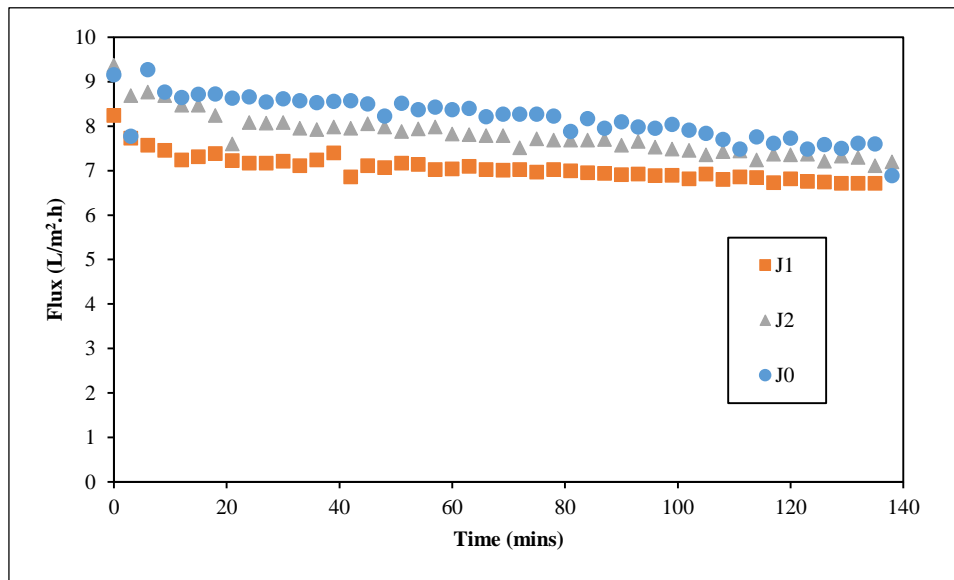

Figure 4-10: Water flux as a function of time for the lab scale set up with deionised water as the feed solution and 2 M ammonium bicarbonate as the draw solution. The membrane was operated in AL-FS mode with the feed and draw solution temperature maintained at $22 \pm 0.5^\circ\text{C}$.

To induce fouling, the same membrane sample was exposed to several forward osmosis runs with undiluted stored urine with each run lasting eight hours. J_0 represents the flux measured with the fresh membrane, J_1 represents the flux after the membrane has been exposed to several forward osmosis runs and J_2 represents the water flux after cleaning the membrane by circulating deionised water for 30 minutes. The virgin membrane achieved an average water flux of $8.8 \text{ L/m}^2\cdot\text{h}$, the fouled membrane $7.8 \text{ L/m}^2\cdot\text{h}$ and the cleaned membrane $8.4 \text{ L/m}^2\cdot\text{h}$. **Figure 4-10** indicates that the water flux after fouling was reduced by 12 % with respect to the initial flux. This reduction is significantly low in

terms of costs that can be incurred when running the process. Membrane cleaning via the circulation of deionised water enabled 95 % recovery of the initial water flux. These fouling experiments illustrate the extremely low fouling propensity of the forward osmosis membranes and the ease of cleaning the membrane which can significantly reduce the operating costs of the process.

4.4.2 Osmotic Backwash

The influence of the duration and draw solution concentration during osmotic backwash on flux recovery is shown in [Figure 4-11](#)~~Figure 4-11~~. The flux recovery improved by increasing the osmotic pressure difference between the feed and draw solution, and the duration of the osmotic backwash. An increase in the osmotic pressure difference results in an increase of reverse water flux that removes foulants from the membrane. However, an unexpected decline in flux recovery during the fourth osmotic backwash was observed. This may be due to the on-set of irreversible fouling on the membrane, a phenomenon associated with all membrane separation process (McCutcheon et al., 2005).

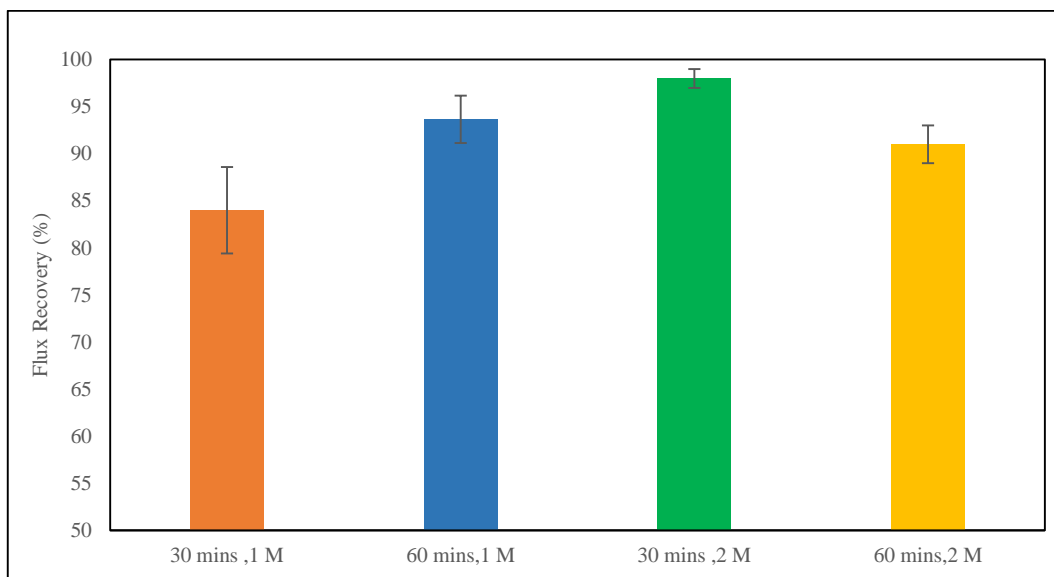

Figure 4-11: Flux recovery during different wash cycles

[Figure 4-12](#)~~Figure 4-12~~a, b and c shows the photographs of the virgin, fouled and cleaned membrane. The brownish colouring on the membrane after a FO run ([Figure 4-12](#)~~Figure 4-12~~b) may be related to the colour of urine, particularly to the TSS rejected by the membrane during the filtration process. During the filtration process, the membrane achieved complete rejection of TSS. [Figure 4-12](#)~~Figure 4-12~~c shows that the efficiency of the osmotic backwash which nearly returns the membrane aspect to its original state. However, it was noted through visual examination that some particulates were permanently bound to the membrane surface.



Figure 4-14(a)



Figure 4-14(b)



Figure 4-14(c)

Figure 4-12: Virgin membrane (a), fouled membrane after a FO run (b) and cleaned membrane after osmotic backwash (c)

4.4.3 SEM and EDX Analysis

After use of the membrane, some particulates remained linked to the membrane surface after cleaning. The nature of the particulates was determined through SEM and EDX analysis by comparing the results obtained by a virgin and fouled membrane.

Figure 4-13

Figure 4-13 shows the results of the SEM and EDX analysis on the virgin membrane. The virgin membrane exhibited peaks of C, S, and O which are the constituent elements of the membrane. Carbon has the highest content as it forms the backbone of the membrane structure. The TFC membrane is composed of a TFC polyamide on polysulfone with an embedded polyester screen, which explains the O and S peaks.

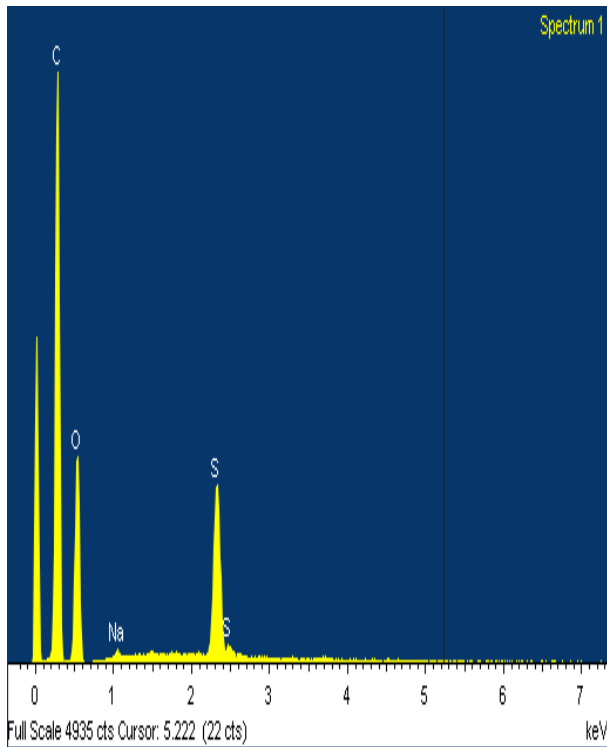

Figure 4-15(a): Virgin membrane(SEM)

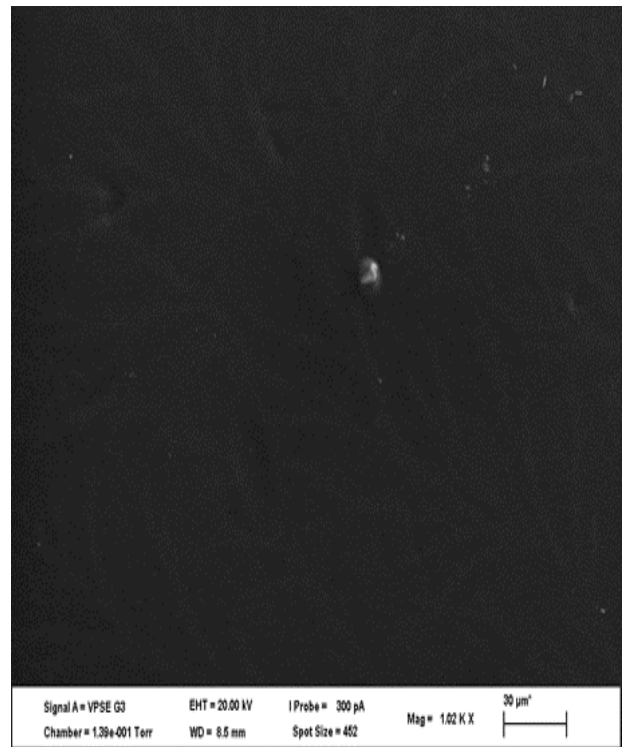

Figure 4-15(a): Virgin membrane(EDX)

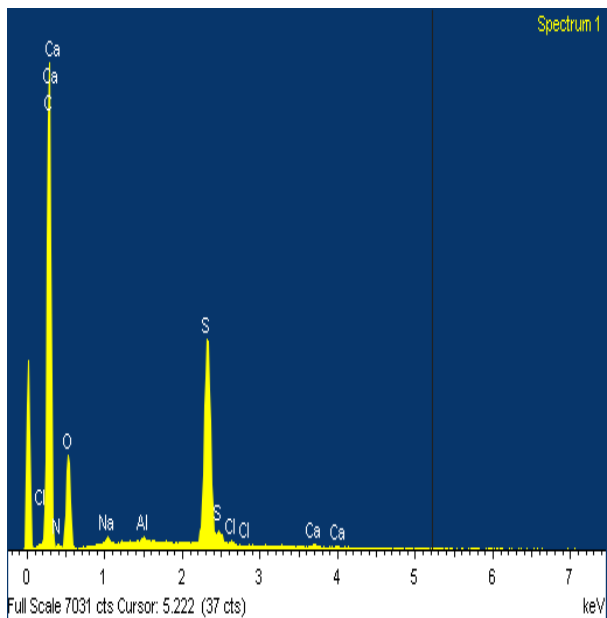

Figure 4-15(c): Fouled Membrane(SEM)

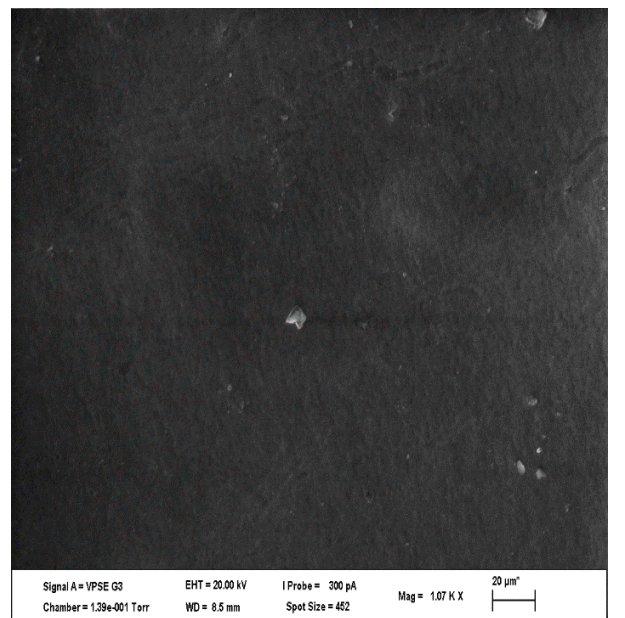

Figure 4-15(d): Fouled Membrane(EDX)

Figure 4-13: SEM –EDX analysis of the virgin membrane and fouled membranes.

Polyamide also forms an integral component of the membrane but the nitrogen from this polymer was not detected. Small amounts of sodium were surprisingly found on the virgin membrane surface, which indicated possible contamination. Achilli et al. (2010) emphasised that in the case of feed and draw solutions containing scale precursor ions (Ba^{2+} , Mg^{2+} , Ca^{2+} , CO_3^{2-} and SO_4^{2-}), the probability of a mineral scale occurring on the membrane surface is enhanced when the feed solution is concentrated above the solubility limits of various water-soluble minerals such as BaSO_4 , CaSO_4 and CaCO_3 . The feed solution for this project contained scale precursors such as Mg^{2+} , Ca^{2+} , CO_3^{2-} and SO_4^{2-} , and the draw solution contained CO_3^{2-} . The fouled membrane (

Figure 4-13

Figure 4-13) exhibited peaks of Mg, Ca, Al and Cl. The Ca peaks appear as the highest which shows that Ca has the highest affinity to bind on the membrane surface.

4.5 A mass balance forward osmosis framework

This section explains the approach adopted in developing the mass balance framework to describe and better understand the observed experimental flux and nutrient rejections.

Solute specie movement across the membrane is governed by mass transfer. The change in mass with time $\left(\frac{dm_i}{dt}\right)$ is then dependent on the mass transfer coefficient (k_i), solute feed concentration (C_{fi}) and the water flux (J_w), as described in Equation (4.1). Refer to appendix D for the derivation of equation 4.1

$$\frac{dm_i}{dt} = J_w \times C_{fi} \times k_i \times A \quad (4.1)$$

Where $k_i = 1 - R_i$ and R_i is the solute rejection for species i , and A is the membrane effective cross-sectional area. The concentration of specie i , in the feed (C_{fi}) was obtained by dividing the mass of solute by the volume of the feed, as observed in Equation (4.2).

$$C_{fi} = \frac{m_i}{V_f} \quad (4.2)$$

The volume of the feed solution V_f was obtained by integrating the flux through Equation (4.3).

$$\frac{dV_f}{dt} = -J_w \times A \quad (4.3)$$

The empirical relationship between flux and time was derived by interpolating the experimental flux using a cubic spline. The transfer coefficient (k_i) is the main parameter of the framework which was calculated through least squares regression by minimising the sum of the square of the residuals as shown by Equation (4.4).

$$error = \sum (C_{fi}^{model} - C_{fi}^{data})^2 \quad (4.4)$$

Equation (4.1) was employed for all the compounds of interest, i.e. phosphates, nitrogen, chlorides, potassium and sodium.. The next step involved integrating the flux to obtain the volume of the feed solution as a function of time. The volume change of the feed tank is described by Equation (4.3).

The solute rejection in Equation (4.1) is the main parameter of the framework that was obtained through least squares regression. The experimental values indicated that the solute rejections decreased with a decrease in water flux, as indicated in ~~Figure 4-8~~ Figure 4-8. The relationship between the rejections and water flux was fitted using a polynomial of degree one and the parameters of the linear equation were found through linear regression.

$$R_i = -J_w a_i + b_i \quad (4.5)$$

Where a_i and b_i are the regression constants.

By incorporating Equation (4.5) into the mass balance Equation (4.1), it was possible to solve for the regression constants through least squares regression. For this purpose, an optimisation function in Matlab, “Fminsearch”, was used. The function gives optimised values of the parameters by utilising least squares algorithms which are inbuilt into Matlab, including: The Gauss Newton algorithm, the Lavenberg-Marquard algorithm, the Trust region-reflective algorithm and the Simplex search algorithm. In order to decrease the running time of the fitting procedure, the “fmincon” function was employed in order to force the algorithm to converge faster.

In this section from Fig 4-14 to Fig 4-17, the lines represents the fitting curve and the dotted points represent the experimental values. The concentration of the urine compounds during a FO run are shown in Figure 4-14. The dotted points represent the experimental points and the straight line represents the fitting curve. The algorithm fits accurately the concentration profiles. The increase in concentration of nutrients on the feed side with time is expected since feed solution volume decreases by the passage of water from the feed solution towards the draw solution.

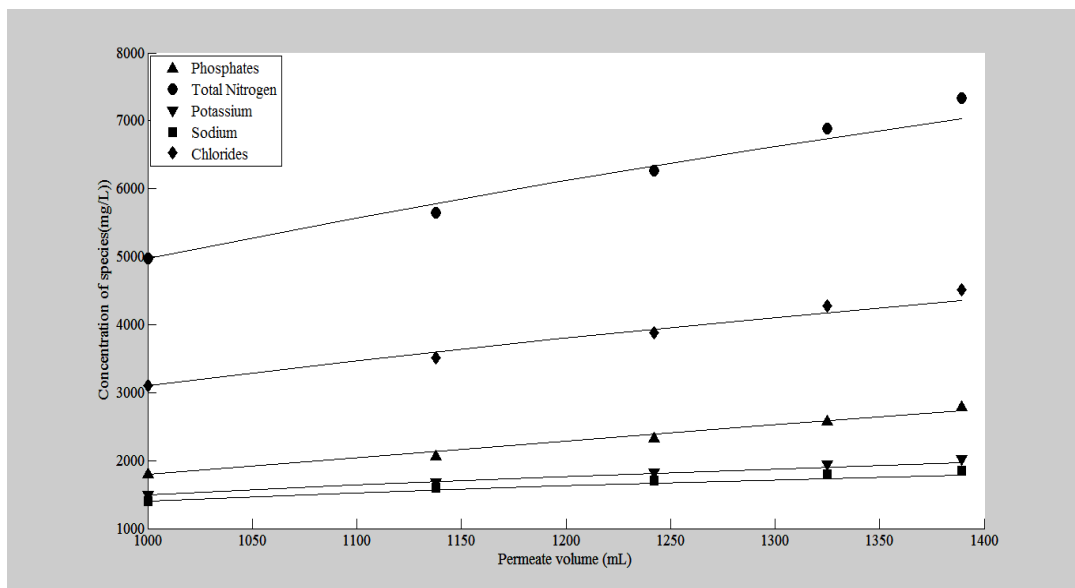

Figure 4-14: Urine compounds concentration in the feed solution during FO run

Figure 4-15 shows the concentration of urine compounds in the draw solution side. The increase in nutrient concentration is related to the compounds migration from the feed solution towards the draw solution. As shown in Figure 4-15, the fit is not as accurate with respect to the draw solution side and this can be explained by the fact that the algorithm is trying to compensate for the good fit on the feed side. The mass balance indicated that not all the matter leaving from the feed

solution is transferred to the draw side; some is trapped onto the membrane surface and the algorithm does not account for this.

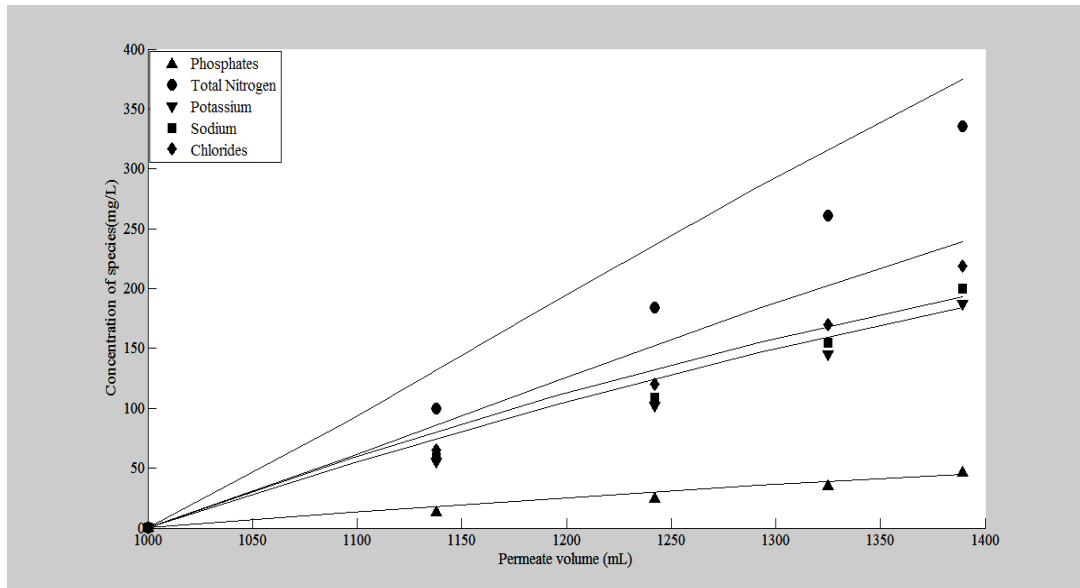

Figure 4-15: Urine compounds concentration in the draw solution during a FO run

Figure 4-16 shows the good fit between the experiential water flux and the predicted water flux.

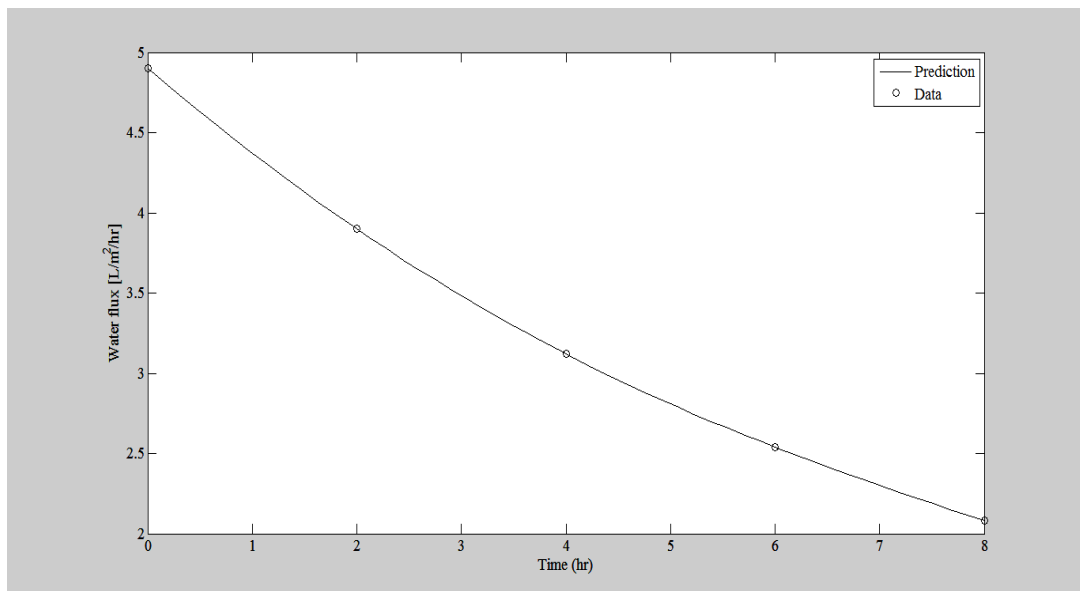

Figure 4-17: Experimental and calculated water flux as a function of time

The nutrient rejections are represented in Figure 4-19. A fairly good fit was obtained from the linear relationship between rejections and water flux. While the framework works extremely well for the

phosphate species (see Figure 4-19), it fits poorly for the other species. A closer look at the flux vs rejection graphs Figure 4-19 suggests that a logarithmic relationship could possibly exist.

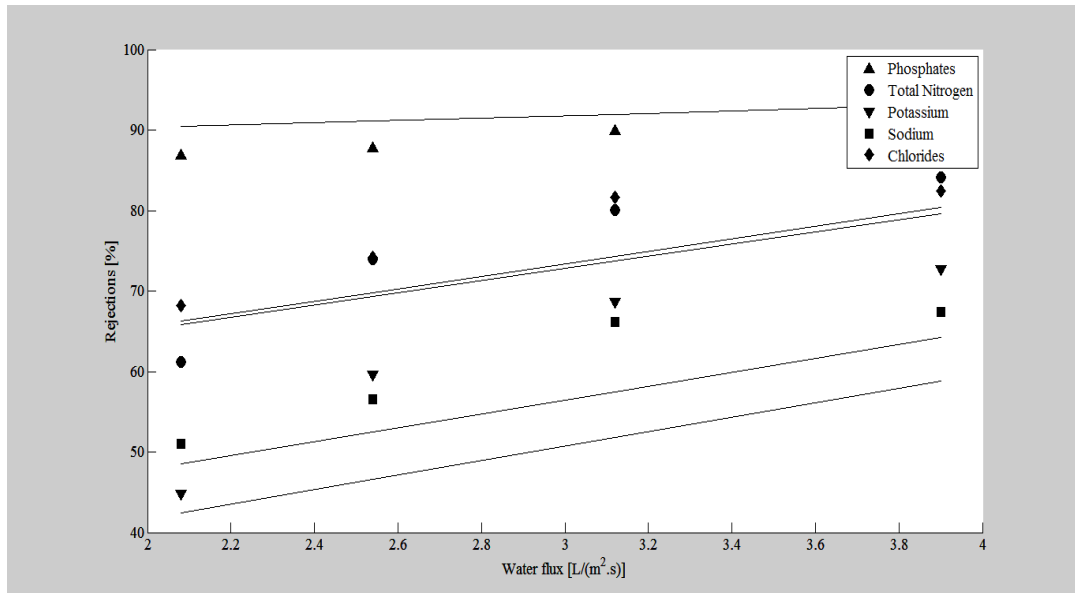

Figure 4-19: Experimental and calculated rejections as a function of water flux

The mass balance framework developed in this thesis provides a good basis for further modelling work to be carried out on the FO process.

5 CONCLUSIONS AND RECOMMENDATIONS

The current study evaluated the feasibility of FO as separation technique for the concentration of stored hydrolysed urine using ammonium bicarbonate as a draw solution. The FO membrane process performance was studied with regards to the parameters that influence water flux and the fouling propensity of a TFC membrane. The ability of the membrane to reject nutrients in the urine feed was also investigated to elucidate the suitability of FO in nutrients recovery from urine. Data fitting was done to check the consistency of the results. A framework based on mass balance which is a starting point for modelling was developed.

Results from the laboratory-scale FO rig used in this study showed that water fluxes as high as 6 L/m².h could be achieved with 2.5 M ammonium bicarbonate as the draw solution and stored urine as the feed. This corresponded to a batch water recovery of 46 %. The stored urine volume reduction would greatly simplify the subsequent transport and disposal of urine for various use. Diluting the stored urine with a factor of three resulted in fluxes as high as 13 L/m².h which can be attributed to the increase in the driving force between the feed and draw solution. Although not treated in detail in this work, the impact of ICP on water flux was noticeable at higher draw solution concentrations. Any progress in FO membrane development should focus on the membrane ability to mitigate the ICP effects. A specific reverse solute flux of approximately 4 g of ammonium bicarbonate for every litre of water that crossed the membrane was obtained. This specific reverse solute flux can be considered low to impact on the process.

The laboratory- scale TFC- FO system was able to reject: > 86 % of total phosphate, > 70 % total nitrogen and > 68 % potassium. A possible explanation for the low rejections of potassium might be negative charge that the membrane assumed as the pH of the urine feed stock increased during the FO process due to the back diffusion of the ammonium bicarbonate draw solutes. The assumed negative charge at higher pH would have attracted more positive ions towards the membrane resulting in higher permeation rates towards the draw solution. The greater than 67 % rejections of total nitrogen, total phosphate and potassium gives a relatively nutrient rich concentrate that can be applied in agriculture. ~~NaCl can act as a regulator of plant growth through the maintenance of an ionic balance within plant cells, osmosis and photosynthesis. However, huge amounts of chloride and sodium can also be harmful to plant growth thus necessitating the need for further treatment after FO. The need for further treatment can also increase the cost of operation.~~

The fouling propensity of stored urine as a feed stream was investigated in this study during the 8 h experiments. Exposure of the TFC –FO membrane to several FO runs with stored urine as the feed and 2 M ammonium bicarbonate as the draw solution resulted in a 12 % flux reduction. This reduction is

significantly low in terms of costs that can be incurred when running the process. Circulation of deionised water achieved 95 % whilst osmotic backwash achieved at least 98 % recovery of the initial water flux. The non-scaling baseline feed solution water flux trend was similar to that of the stored urine feed indicating the low membrane fouling. These short term fouling experiments illustrate the extremely low fouling propensity of the forward osmosis membranes and the easy of cleaning the membrane. Despite the favourable fouling propensity of the TFC membrane observed in this study, the author of this thesis strongly feels the need to perform longer duration fouling experiments to reproduce conditions from practical applications. Membrane surface characterisation showed the affinity of calcium to bind to the membrane surface despite calcium concentration in the stored urine being low. This means that urine feed stream calcium (a scale precursor) composition will need monitoring to avoid mineral scaling.

The framework developed in this study agrees with the experimental values of water flux and compounds concentration in the feed solution. However, the predicted solute concentrations in the draw solution and nutrient rejections deviated from the experimental values and this could be attributed to the inability of the model to cater for the bi-directional movement of compounds across the membrane. Furthermore, the framework does not account for the compounds that get adsorbed onto the membrane surface. It is recommended that the model be improved to cater for the different draw and feed solution concentrations making it applicable to different end-users.

The results from this study illustrates the possibilities of what can be achieved with a FO as urine separation step. ~~However, it has to be noted that to clearly achieve the goal of harnessing fertiliser and re-usable water from urine, a pre-screening step is required that can harvest sodium and chlorides that might be harmful to plant growth.~~ Ways to recover and replenish the draw solution have to be developed for the economic viability of the process. One possible way of reconstituting the draw solution is to strip the stored urine of the high ammonia that it contains through the use of a combination a stripper and absorber. [A proper discussion of the draw solutes reconstitution process is addressed is in section 6.2.](#)

6 PERSPECTIVE

This section describes how FO can be implemented in the context of the excreta shit flow diagram presented in chapter 1. The possible use of low grade heat from faecal sludge for providing the energy needed for water recovery from the diluted draw solution is described. Possible ways in which draw solutes can be reconstituted from both the feed and draw solutions are also described.

6.1 Use of low grade heat from faecal sludge to recover the draw solution-interpolating literature data

The decomposition of ammonium bicarbonate solution upon moderate heating to yield ammonia and carbon dioxide gases can be summarised by the following equation:

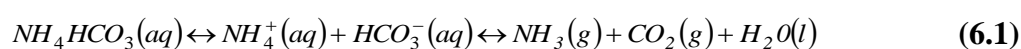

Several authors (McGinnis and Elimelech, 2007, McCutcheon et al., 2005, McCutcheon et al., 2006, McGinnis et al., 2013, Kim et al., 2015, Cath et al., 2006) have indicated that moderate heating of ammonium bicarbonate results in its decomposition into ammonia and carbon dioxide gases that can be recycled to regenerate the draw solution. Kim et al. (2015) were able to reduce the concentration of a 1 M ammonium bicarbonate solution to 20 mg/L through the use of simple rotary evaporator that was heated to 95 °C and maintained for 2 h at atmospheric pressure. However, the authors, through the plotting of a pressure vs decomposition temperature curve for ammonium bicarbonate concluded that acceptable separation could be achieved at lower temperatures through the utilisation of low grade heat.

The heat energy required to decompose ammonium bicarbonate can be obtained from faecal sludge as envisioned in the PRG Internal Discussion Excreta flow diagram in Chapter 1 through the harnessing of energy from the faecal streams. Studies done by (Komakech et al., 2014) and (Zuma et al., 2015) showed that raw sludge has a calorific value (energy stored within the substance) of 17.3 MJ/kg and 14.3 MJ/kg dry solids respectively. The results from the two authors agree well with results from other researchers (Muspratt et al., 2014, Rose et al., 2015, Hu et al., 2016, Diener et al., 2014). Sludge can be utilised as a fuel to decompose ammonium bicarbonate and ensure a closed loop in the recycling of the draw solution. Recycling of ammonium bicarbonate draw solution makes the FO process economically feasible.

Pilot scale results from the operation of a desalination plant that utilised ammonium bicarbonate as a draw solution by (Kim et al., 2015, McGinnis et al., 2013) indicated that to produce 1 000 L of water between 265-300 kWh of thermal energy was needed. Assuming the waste case scenario (300 kWh) energy to produce 1 000 L of water, the amount of sludge required based on the above 2 calorific values is summarised in [Table 6-1](#)

Table 6-1: Calorific value of sludge and an approximation of the sludge required to produce a 1000 L of product water.

	(Zuma et al., 2015)	(Komakech et al., 2014)
Calorific Value(MJ/kg) dry sludge	14.3	17.3
kg of sludge required	75.5	62.4

6.2 Conceptual process flow diagram for reconstituting FO draw solutes.

After urea hydrolysis the majority of nitrogen in urine exists in the form of ammonium/ammonia. At high pH greater than 11 it exists exclusively as ammonia. The ammonia gas can be separated from the liquid and subsequent concentration in pure water is possible. The possibility of harvesting ammonia from stored urine and subsequently producing ammonium bicarbonate allows for recycling of the draw solution utilised in the FO set-up in this study.

A conceptual process flow diagram is presented in this thesis in which the process consists of a stripper for ammonia removal from urine and an absorber to remove the ammonia from the air thus producing a concentrated ammonia solution. To reduce ammonia loss air will be recirculated from the absorber to the stripper. To ensure low ammonia concentration in the stored urine and high concentrations in the ammonia solution the following operating conditions are recommended: low pressure and high temperature for the stripper and high pressure and low pressure for the stripper. The same absorber stripper combination is utilised to recover the draw solutes components by stripping the diluted draw solution of carbon dioxide and recycling it to reconstitute the draw solution. It is important to note that the processes flow diagram shown in Figure 20 is only conceptual and a further analysis of the mass flow rates, energy requirements and separation efficiencies is needed to properly understand the economic feasibility of the process.

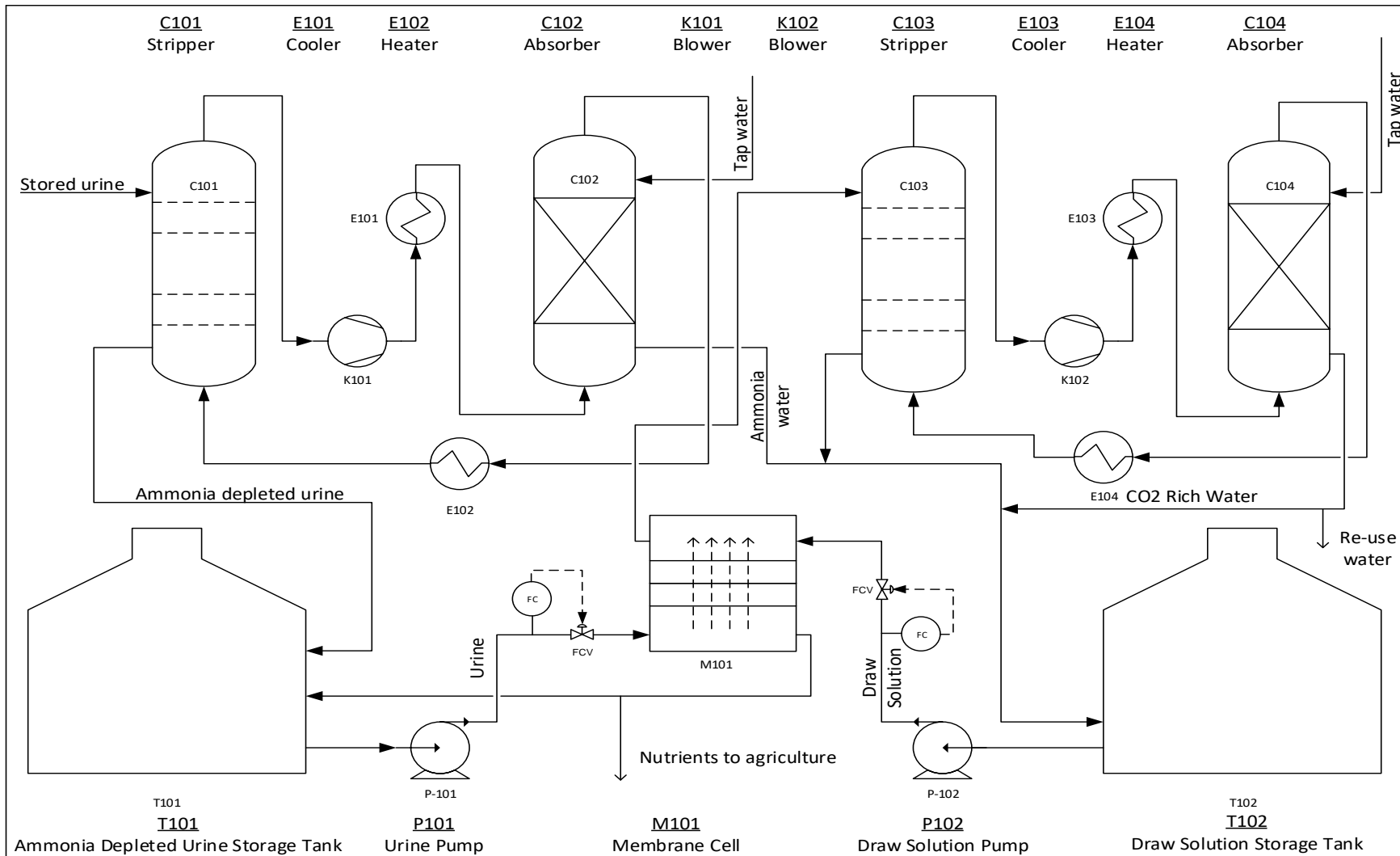

Figure 4.20: Conceptual process flow diagram that includes a FO rig together with an absorber stripper combination on both the draw and feed solution

7 REFERENCES

- ABOUSHINA, R. M. & NGHIEM, L. D. 2014. Removal of dissolved organics from produced water by forward osmosis. *Desalination and Water Treatment*, 52, 570-579.
- ACHILLI, A., CATH, T. Y. & CHILDRESS, A. E. 2010. Selection of inorganic-based draw solutions for forward osmosis applications. *Journal of Membrane Science*, 364, 233-241.
- ADHAM, S. 2007. *Dewatering reverse osmosis concentrate from water reuse applications using forward osmosis*, WaterReuse Foundation.
- AGASHICHEV, S. P. 2005. Reverse osmosis at elevated temperatures: influence of temperature on degree of concentration polarization and transmembrane flux. *Desalination*, 179, 61-72.
- ALTURKI, A. A., MCDONALD, J. A., KHAN, S. J., PRICE, W. E., NGHIEM, L. D. & ELIMELECH, M. 2013. Removal of trace organic contaminants by the forward osmosis process. *Separation and Purification Technology*, 103, 258-266.
- ANTONINI, S., PARIS, S., EICHERT, T. & CLEMENS, J. 2011. Nitrogen and phosphorus recovery from human urine by struvite precipitation and air stripping in Vietnam. *CLEAN–Soil, Air, Water*, 39, 1099-1104.
- BABU, B. R., RASTOGI, N. & RAGHAVARAO, K. 2006. Effect of process parameters on transmembrane flux during direct osmosis. *Journal of membrane science*, 280, 185-194.
- BAN, Z. & DAVE, G. 2004. Laboratory studies on recovery of N and P from human urine through struvite crystallisation and zeolite adsorption. *Environmental technology*, 25, 111-121.
- BATCHELDCR, G. W. 1965. PROCESS FOR THE DEMORALIZATION. Google Patents.
- BEACH, H. 1971. COMPOSITION AND CONCENTRATIVE PROPERTIES OF HUMAN URINE.
- BISCHEL, H. N., SCHINDELHOLZ, S., SCHOGER, M., DECREY, L., BUCKLEY, C. A., UDERT, K. M. & KOHN, T. 2016. Bacteria inactivation during the drying of struvite fertilizers produced from stored urine. *Environmental Science & Technology*.
- BORER, C. H., STILES, W. J., STEVENSON, J. C. & CABANILLAS, K. E. 2014. Assessment of forward osmosis as a possible mitigation strategy for urine management during extended cave exploration. *J Cave Karst Studies*, 76, 26-29.
- BUCKWALTER, P., EMBAYE, T., GORMLY, S. & TRENT, J. D. 2013. Dewatering microalgae by forward osmosis. *Desalination*, 312, 19-22.
- CATH, T. Y., CHILDRESS, A. E. & ELIMELECH, M. 2006. Forward osmosis: principles, applications, and recent developments. *Journal of membrane science*, 281, 70-87.
- CHEN, L., GU, Y., CAO, C., ZHANG, J., NG, J.-W. & TANG, C. 2014. Performance of a submerged anaerobic membrane bioreactor with forward osmosis membrane for low-strength wastewater treatment. *Water research*, 50, 114-123.
- CHINNUSAMY, V., JAGENDORF, A. & ZHU, J.-K. 2005. Understanding and improving salt tolerance in plants. *Crop Science*, 45, 437-448.
- CHUNG, T.-S., ZHANG, S., WANG, K. Y., SU, J. & LING, M. M. 2012. Forward osmosis processes: yesterday, today and tomorrow. *Desalination*, 287, 78-81.
- CODAY, B. D., YAFFE, B. G., XU, P. & CATH, T. Y. 2014. Rejection of trace organic compounds by forward osmosis membranes: a literature review. *Environmental science & technology*, 48, 3612-3624.
- DIENER, S., SEMIYAGA, S., NIWAGABA, C. B., MUSPRATT, A. M., GNING, J. B., MBÉGUÉRÉ, M., ENNIN, J. E., ZURBRUGG, C. & STRANDE, L. 2014. A value

- proposition: Resource recovery from faecal sludge—Can it be the driver for improved sanitation? *Resources, Conservation and Recycling*, 88, 32-38.
- ELIMELECH, M. & PHILLIP, W. A. 2011. The future of seawater desalination: energy, technology, and the environment. *Science*, 333, 712-717.
- ELLEDGE, M. F. & MCCLATCHEY, M. 2013. India, Urban Sanitation, and the Toilet Challenge. *RTI Research Brief*.
- ETTER, B., HUG, A. & UDERT, K. M. 2013. Total nutrient recovery from urine-operation of a pilot-scale nitrification reactor. *Proceedings of WEF/IWA Nutrient Removal and Recovery 2013: Trends in Resource Recovery and Use*, 28-31.
- FAKHRU'L-RAZI, A., PENDASHTEH, A., ABDULLAH, L. C., BIAK, D. R. A., MADAENI, S. S. & ABIDIN, Z. Z. 2009. Review of technologies for oil and gas produced water treatment. *Journal of Hazardous Materials*, 170, 530-551.
- FATTA-KASSINOS, D., BESTER, K. & KÜMMERER, K. 2009. Xenobiotics in the urban water cycle. Springer, Dordrecht.
- FLYNN, M. T., SOLER, M., SHULL, S., BROYAN, J., CHAMBLISS, J., HOWE, A. S., GORMLY, S., HAMMOUDEH, M., SHAW, H. & HOWARD, K. Forward osmosis cargo transfer bag. 42nd International Conference on Environmental Systems, 2012. 3599.
- FRANK, B. S. 1972. Desalination of sea water. Google Patents.
- FREEMAN, M. C., OGDEN, S., JACOBSON, J., ABBOTT, D., ADDISS, D. G., AMNIE, A. G., BECKWITH, C., CAIRNCROSS, S., CALLEJAS, R. & COLFORD JR, J. M. 2013. Integration of water, sanitation, and hygiene for the prevention and control of neglected tropical diseases: a rationale for inter-sectoral collaboration. *PLoS neglected tropical diseases*, 7, e2439.
- FRITZMANN, C., LÖWENBERG, J., WINTGENS, T. & MELIN, T. 2007. State-of-the-art of reverse osmosis desalination. *Desalination*, 216, 1-76.
- GAO, Y., WANG, Y.-N., LI, W. & TANG, C. Y. 2014. Characterization of internal and external concentration polarizations during forward osmosis processes. *Desalination*, 338, 65-73.
- GE, Q., SU, J., CHUNG, T.-S. & AMY, G. 2010. Hydrophilic superparamagnetic nanoparticles: synthesis, characterization, and performance in forward osmosis processes. *Industrial & Engineering Chemistry Research*, 50, 382-388.
- GLEW, D. N. 1965. Process for liquid recovery and solution concentration. Google Patents.
- GOLDER, D., RANA, S., SARKAR, D. & JANA, B. 2007. Human urine is an excellent liquid waste for the culture of fish food organism, *Moina micrura*. *Ecological engineering*, 30, 326-332.
- GOOSEN, M. F., SABLANI, S. S., AL-MASKARI, S. S., AL-BELUSHI, R. H. & WILF, M. 2002. Effect of feed temperature on permeate flux and mass transfer coefficient in spiral-wound reverse osmosis systems. *Desalination*, 144, 367-372.
- GORMLY, S. & FLYNN, M. 2007. Lightweight Contingency Urine Recovery System Concept Development. SAE Technical Paper.
- GRIFFITH, D. P., MUSER, D. Á. & ITIN, C. 1976. Urease. The primary cause of infection-induced urinary stones. *Investigative urology*, 13, 346-350.
- HANCOCK, N. T. & CATH, T. Y. 2009. Solute coupled diffusion in osmotically driven membrane processes. *Environmental science & technology*, 43, 6769-6775.
- HANCOCK, N. T., XU, P., ROBY, M. J., GOMEZ, J. D. & CATH, T. Y. 2013. Towards direct potable reuse with forward osmosis: Technical assessment of long-term process performance at the pilot scale. *Journal of Membrane Science*, 445, 34-46.

- HELLSTRÖM, D., JOHANSSON, E. & GRENNBERG, K. 1999. Storage of human urine: acidification as a method to inhibit decomposition of urea. *Ecological Engineering*, 12, 253-269.
- HICKENBOTTOM, K. L., HANCOCK, N. T., HUTCHINGS, N. R., APPLETON, E. W., BEAUDRY, E. G., XU, P. & CATH, T. Y. 2013. Forward osmosis treatment of drilling mud and fracturing wastewater from oil and gas operations. *Desalination*, 312, 60-66.
- HÖGLUND, C., VINNERÅS, B., STENSTRÖM, T. & JÖNSSON, H. 2000. Variation of chemical and microbial parameters in collection and storage tanks for source separated human urine. *Journal of Environmental Science & Health Part A*, 35, 1463-1475.
- HOLLOWAY, R. W., CHILDRESS, A. E., DENNETT, K. E. & CATH, T. Y. 2007. Forward osmosis for concentration of anaerobic digester centrate. *Water Research*, 41, 4005-4014.
- HU, M., GAO, L., CHEN, Z., MA, C., ZHOU, Y., CHEN, J., MA, S., LAGHARI, M., XIAO, B. & ZHANG, B. 2016. Syngas production by catalytic in-situ steam co-gasification of wet sewage sludge and pine sawdust. *Energy Conversion and Management*, 111, 409-416.
- JACKSON, M. 2014. *Evaluation of an osmotic dilution process for tertiary wastewater treatment*. Humboldt State University.
- JACOB, A. A critical review of the history, development and future prospects for Forward Osmosis.
- JAWOR, A. & HOEK, E. M. 2009. Effects of feed water temperature on inorganic fouling of brackish water RO membranes. *Desalination*, 235, 44-57.
- JIN, X., JAWOR, A., KIM, S. & HOEK, E. M. 2009. Effects of feed water temperature on separation performance and organic fouling of brackish water RO membranes. *Desalination*, 239, 346-359.
- JÖNSSON, H., BAKY, A., JEPPSSON, U., HELLSTRÖM, D. & KÄRRMAN, E. 2005. Composition of urine, faeces, greywater and biowaste for utilisation in the URWARE model. *Urban water report*.
- JÖNSSON, H., VINNERÅS, B., HÖGLUND, C., STENSTRÖM, T., DALHAMMAR, G. & KIRCHMANN, H. 2000. Recycling source separated human urine. *VA-forsk report*, 1.
- KARAK, T. & BHATTACHARYYA, P. 2011. Human urine as a source of alternative natural fertilizer in agriculture: A flight of fancy or an achievable reality. *Resources, Conservation and Recycling*, 55, 400-408.
- KESSLER, J. & MOODY, C. 1976. Drinking water from sea water by forward osmosis. *Desalination*, 18, 297-306.
- KIM, C., LEE, S. & HONG, S. 2012. Application of osmotic backwashing in forward osmosis: mechanisms and factors involved. *Desalination and Water Treatment*, 43, 314-322.
- KIM, J. & DIGIANO, F. A. 2009. Fouling models for low-pressure membrane systems. *Separation and Purification Technology*, 68, 293-304.
- KIM, Y., LEE, J. H., KIM, Y. C., LEE, K. H., PARK, I. S. & PARK, S.-J. 2015. Operation and simulation of pilot-scale forward osmosis desalination with ammonium bicarbonate. *Chemical Engineering Research and Design*, 94, 390-395.
- KIRCHMANN, H. & PETTERSSON, S. 1994. Human urine-chemical composition and fertilizer use efficiency. *Fertilizer research*, 40, 149-154.
- KOCHUBOVSKI, M. 2007. Use of membrane filtration for water treatment with examples from the republic of Macedonia. *Nanotechnology-Toxicological Issues and Environmental Safety and Environmental Safety*. Springer.
- KOMAKECH, A. J., BANADDA, N. E., KINOBE, J. R., KASISIRA, L., SUNDBERG, C., GEBRESENBET, G. & VINNERÅS, B. 2014. Characterization of municipal waste in Kampala, Uganda. *Journal of the Air & Waste Management Association*, 64, 340-348.

- KRAVATH, R. E. & DAVIS, J. A. 1975. Desalination of sea water by direct osmosis. *Desalination*, 16, 151-155.
- LATTEMANN, S. & HÖPNER, T. 2008. Environmental impact and impact assessment of seawater desalination. *Desalination*, 220, 1-15.
- LE, N. L. & NUNES, S. P. 2016. Materials and membrane technologies for water and energy sustainability. *Sustainable Materials and Technologies*, 7, 1-28.
- LEE, M. K. & VAN IERSEL, M. W. 2008. Sodium chloride effects on growth, morphology, and physiology of chrysanthemum (*Chrysanthemum morifolium*). *HortScience*, 43, 1888-1891.
- LI, D., ZHANG, X., YAO, J., SIMON, G. P. & WANG, H. 2011. Stimuli-responsive polymer hydrogels as a new class of draw agent for forward osmosis desalination. *Chem. Commun.*, 47, 1710-1712.
- LIN, J. C.-T., LEE, D.-J. & HUANG, C. 2010. Membrane fouling mitigation: membrane cleaning. *Separation Science and Technology*, 45, 858-872.
- LOEB, S., TITELMAN, L., KORNGOLD, E. & FREIMAN, J. 1997. Effect of porous support fabric on osmosis through a Loeb-Sourirajan type asymmetric membrane. *Journal of Membrane Science*, 129, 243-249.
- LUTCHMIAH, K., LAUBER, L., ROEST, K., HARMSSEN, D. J., POST, J. W., RIETVELD, L. C., VAN LIER, J. B. & CORNELISSEN, E. R. 2014a. Zwitterions as alternative draw solutions in forward osmosis for application in wastewater reclamation. *Journal of Membrane Science*, 460, 82-90.
- LUTCHMIAH, K., VERLIEFDE, A., ROEST, K., RIETVELD, L. C. & CORNELISSEN, E. R. 2014b. Forward osmosis for application in wastewater treatment: a review. *Water research*, 58, 179-197.
- MAURER, M., PRONK, W. & LARSEN, T. 2006. Treatment processes for source-separated urine. *Water research*, 40, 3151-3166.
- MCCOY, D., KEMBHAVI, G., PATEL, J. & LUIINTEL, A. 2009. The Bill & Melinda Gates Foundation's grant-making programme for global health. *The Lancet*, 373, 1645-1653.
- MCCUTCHEON, J. R. & ELIMELECH, M. 2006. Influence of concentrative and dilutive internal concentration polarization on flux behavior in forward osmosis. *Journal of Membrane Science*, 284, 237-247.
- MCCUTCHEON, J. R., MCGINNIS, R. L. & ELIMELECH, M. 2005. A novel ammonia—carbon dioxide forward (direct) osmosis desalination process. *Desalination*, 174, 1-11.
- MCCUTCHEON, J. R., MCGINNIS, R. L. & ELIMELECH, M. 2006. Desalination by ammonia—carbon dioxide forward osmosis: influence of draw and feed solution concentrations on process performance. *Journal of membrane science*, 278, 114-123.
- MCGINNIS, R. L. 2002. Osmotic desalination process. Google Patents.
- MCGINNIS, R. L. & ELIMELECH, M. 2007. Energy requirements of ammonia—carbon dioxide forward osmosis desalination. *Desalination*, 207, 370-382.
- MCGINNIS, R. L. & ELIMELECH, M. 2008. Global challenges in energy and water supply: the promise of engineered osmosis. *Environmental science & technology*, 42, 8625-8629.
- MCGINNIS, R. L., HANCOCK, N. T., NOWOSIELSKI-SLEPOWRON, M. S. & MCGURGAN, G. D. 2013. Pilot demonstration of the NH₃/CO₂ forward osmosis desalination process on high salinity brines. *Desalination*, 312, 67-74.
- MEHTA, G. D. 1982. Further results on the performance of present-day osmotic membranes in various osmotic regions. *Journal of Membrane Science*, 10, 3-19.
- MEINZINGER, F. & OLDENBURG, M. 2009. Characteristics of source-separated household wastewater flows: a statistical assessment.

- MI, B. & ELIMELECH, M. 2008. Chemical and physical aspects of organic fouling of forward osmosis membranes. *Journal of Membrane Science*, 320, 292-302.
- MI, B. & ELIMELECH, M. 2010. Organic fouling of forward osmosis membranes: fouling reversibility and cleaning without chemical reagents. *Journal of membrane science*, 348, 337-345.
- MUSPRATT, A. M., NAKATO, T., NIWAGABA, C., DIONE, H., KANG, J., STUPIN, L., REGULINSKI, J., MBÉGUÉRIÉ, M. & STRANDE, L. 2014. Fuel potential of faecal sludge: calorific value results from Uganda, Ghana and Senegal. *Journal of Water Sanitation and Hygiene for Development*, 4, 223-230.
- NG, H. Y. & ELIMELECH, M. 2004. Influence of colloidal fouling on rejection of trace organic contaminants by reverse osmosis. *Journal of membrane science*, 244, 215-226.
- NGHIEM, L. D. & HAWKES, S. 2007. Effects of membrane fouling on the nanofiltration of pharmaceutically active compounds (PhACs): mechanisms and role of membrane pore size. *Separation and Purification Technology*, 57, 176-184.
- NGUYEN, N. C., CHEN, S.-S., YANG, H.-Y. & HAU, N. T. 2013. Application of forward osmosis on dewatering of high nutrient sludge. *Bioresource technology*, 132, 224-229.
- NIELSEN, C. H. 2009. Biomimetic membranes for sensor and separation applications. *Analytical and bioanalytical chemistry*, 395, 697-718.
- NORDIN, A., OTTOSON, J. & VINNERÅS, B. 2009. Sanitation of faeces from source-separating dry toilets using urea. *Journal of applied microbiology*, 107, 1579-1587.
- NUNES, S. P. & PEINEMANN, K.-V. 2001. *Membrane technology*, Wiley Online Library.
- NYENJE, P., FOPPEN, J., UHLENBROOK, S., KULABAKO, R. & MUWANGA, A. 2010. Eutrophication and nutrient release in urban areas of sub-Saharan Africa—a review. *Science of the Total Environment*, 408, 447-455.
- PARIDA, V. & NG, H. Y. 2013. Forward osmosis organic fouling: Effects of organic loading, calcium and membrane orientation. *Desalination*, 312, 88-98.
- PEÑA, N., GALLEGOS, S., DEL VIGO, F. & CHESTERS, S. 2013. Evaluating impact of fouling on reverse osmosis membranes performance. *Desalination and Water Treatment*, 51, 958-968.
- PENDERGAST, M. M., NOWOSIELSKI-SLEPOWRON, M. S. & TRACY, J. 2016. Going big with forward osmosis. *Desalination and Water Treatment*, 1-10.
- PHILLIP, W. A., YONG, J. S. & ELIMELECH, M. 2010. Reverse draw solute permeation in forward osmosis: modeling and experiments. *Environmental science & technology*, 44, 5170-5176.
- PHUNTSHO, S. 2012. *A novel fertiliser drawn forward osmosis desalination for fertigation*.
- PHUNTSHO, S., SHON, H. K., HONG, S., LEE, S. & VIGNESWARAN, S. 2011. A novel low energy fertilizer driven forward osmosis desalination for direct fertigation: evaluating the performance of fertilizer draw solutions. *Journal of membrane science*, 375, 172-181.
- PHUNTSHO, S., SHON, H. K., MAJEED, T., EL SALIBY, I., VIGNESWARAN, S., KANDASAMY, J., HONG, S. & LEE, S. 2012. Blended fertilizers as draw solutions for fertilizer-drawn forward osmosis desalination. *Environmental science & technology*, 46, 4567-4575.
- PLAKAS, K., KARABELAS, A., WINTGENS, T. & MELIN, T. 2006. A study of selected herbicides retention by nanofiltration membranes—the role of organic fouling. *Journal of Membrane Science*, 284, 291-300.
- PRADHAN, S. K., HOLOPAINEN, J. K., WEISELL, J. & HEINONEN-TANSKI, H. 2010. Human urine and wood ash as plant nutrients for red beet (*Beta vulgaris*) cultivation: impacts on yield quality. *Journal of agricultural and food chemistry*, 58, 2034-2039.

- PRADHAN, S. K., NERG, A.-M., SJÖBLOM, A., HOLOPAINEN, J. K. & HEINONEN-TANSKI, H. 2007. Use of human urine fertilizer in cultivation of cabbage (*Brassica oleracea*)—impacts on chemical, microbial, and flavor quality. *Journal of agricultural and food chemistry*, 55, 8657-8663.
- PRONK, W., ZULEEG, S., LIENERT, J., ESCHER, B., KOLLER, M., BERNER, A., KOCH, G. & BOLLER, M. 2007. Pilot experiments with electro dialysis and ozonation for the production of a fertiliser from urine. *Water science and technology*, 56, 219-227.
- QADOS, A. M. A. 2011. Effect of salt stress on plant growth and metabolism of bean plant *Vicia faba* (L.). *Journal of the Saudi Society of Agricultural Sciences*, 10, 7-15.
- RANDALL, D. G., KRÄHENBÜHL, M., KÖPPING, I., LARSEN, T. A. & UDERT, K. M. 2016. A novel approach for stabilizing fresh urine by calcium hydroxide addition. *Water research*, 95, 361-369.
- ROSE, C., PARKER, A., JEFFERSON, B. & CARTMELL, E. 2015. The characterisation of faeces and urine; a review of the literature to inform advanced treatment technology. *Critical Reviews in Environmental Science and Technology*, 00-00.
- SAIRAM, M., SEREEWATTHANAWUT, E., LI, K., BISMARCK, A. & LIVINGSTON, A. 2011. Method for the preparation of cellulose acetate flat sheet composite membranes for forward osmosis—desalination using MgSO₄ draw solution. *Desalination*, 273, 299-307.
- SHE, Q., JIN, X., LI, Q. & TANG, C. Y. 2012. Relating reverse and forward solute diffusion to membrane fouling in osmotically driven membrane processes. *Water research*, 46, 2478-2486.
- SILVA, L. L., SALES, J. C., CAMPOS, J. C., BILA, D. M. & FONSECA, F. V. 2016. Advanced oxidative processes and membrane separation for micropollutant removal from biotreated domestic wastewater. *Environmental Science and Pollution Research*, 1-10.
- SPIEGLER, K. & MACLEISH, J. 1981. Molecular (osmotic and electro-osmotic) backwash of cellulose acetate hyperfiltration membranes. *Journal of Membrane Science*, 8, 173-192.
- STACHE, K. 1989. Apparatus for transforming sea water, brackish water, polluted water or the like into a nutritious drink by means of osmosis. Google Patents.
- STEVENSON, A. E., WRIGGLESWORTH, D. J., SMITH, B. H. & MARKWELL, P. J. 2000. Effects of dietary potassium citrate supplementation on urine pH and urinary relative supersaturation of calcium oxalate and struvite in healthy dogs. *American journal of veterinary research*, 61, 430-435.
- STRATHMANN, H. 2004. Preface. *Membrane Science and Technology*, 9, v-vi.
- SUTZKOVER-GUTMAN, I. & HASSON, D. 2010. Feed water pretreatment for desalination plants. *Desalination*, 264, 289-296.
- TAN, C., LEFEBVRE, O., ZHANG, J., NG, H. & ONG, S. 2012. Membrane processes for desalination: overview. *Membrane Technology and Environmental Applications*.
- TANG, C., ZHAO, Y., WANG, R., HÉLIX-NIELSEN, C. & FANE, A. 2013. Desalination by biomimetic aquaporin membranes: Review of status and prospects. *Desalination*, 308, 34-40.
- TANG, C. Y., SHE, Q., LAY, W. C., WANG, R. & FANE, A. G. 2010. Coupled effects of internal concentration polarization and fouling on flux behavior of forward osmosis membranes during humic acid filtration. *Journal of Membrane Science*, 354, 123-133.
- TAYLOR, E. N. & CURHAN, G. C. 2006. Body size and 24-hour urine composition. *American journal of kidney diseases*, 48, 905-915.
- UDERT, K. M., BUCKLEY, C. A., WÄCHTER, M., MCARDELL, C. S., KOHN, T., STRANDE, L., ZÖLLIG, H., FUMASOLI, A., OBERSON, A. & ETTER, B. 2015.

- Technologies for the treatment of source-separated urine in the eThekweni Municipality. *Water SA*, 41, 212-221.
- UDERT, K. M., LARSEN, T. A., BIEBOW, M. & GUJER, W. 2003. Urea hydrolysis and precipitation dynamics in a urine-collecting system. *Water Research*, 37, 2571-2582.
- VALLADARES LINARES, R., YANGALI-QUINTANILLA, V., LI, Z. & AMY, G. 2011. Rejection of micropollutants by clean and fouled forward osmosis membrane. *Water research*, 45, 6737-6744.
- VANE, L. M. 2008. Separation technologies for the recovery and dehydration of alcohols from fermentation broths. *Biofuels, Bioproducts and Biorefining*, 2, 553-588.
- VINNERÅS, B. 2001. Faecal separation and urine diversion for nutrient management of household biodegradable waste and wastewater.
- VINNERÅS, B. 2002. *Possibilities for sustainable nutrient recycling by faecal separation combined with urine.*
- VOGEL, D., SIMON, A., ALTURKI, A. A., BILITEWSKI, B., PRICE, W. E. & NGHIEM, L. D. 2010. Effects of fouling and scaling on the retention of trace organic contaminants by a nanofiltration membrane: the role of cake-enhanced concentration polarisation. *Separation and Purification Technology*, 73, 256-263.
- VON MÜNCH, E. 2009. Basic overview of urine d components (waterless urinals, UD toilet bowls and pans, piping and storage).
- WAGNER, J. 2000. Membrane Filtration Handbook. *Revision*, 2, 8-15.
- WANG, Y., WICAKSANA, F., TANG, C. Y. & FANE, A. G. 2010. Direct microscopic observation of forward osmosis membrane fouling. *Environmental science & technology*, 44, 7102-7109.
- WILSENACH, J. A. & VAN LOOSDRECHT, M. C. 2004. Effects of separate urine collection on advanced nutrient removal processes. *Environmental science & technology*, 38, 1208-1215.
- WINKER, M., VINNERÅS, B., MUSKOLUS, A., ARNOLD, U. & CLEMENS, J. 2009. Fertiliser products from new sanitation systems: Their potential values and risks. *Bioresource Technology*, 100, 4090-4096.
- WOOLLEY, S., COTTINGHAM, R., POCOCK, J. & BUCKLEY, C. 2014. Shear rheological properties of fresh human faeces with different moisture content. *Water SA*, 40, 273-276.
- XU, K., LI, J., ZHENG, M., ZHANG, C., XIE, T. & WANG, C. 2015. The precipitation of magnesium potassium phosphate hexahydrate for P and K recovery from synthetic urine. *Water research*, 80, 71-79.
- XU, P., DREWES, J. E., KIM, T.-U., BELLONA, C. & AMY, G. 2006. Effect of membrane fouling on transport of organic contaminants in NF/RO membrane applications. *Journal of Membrane Science*, 279, 165-175.
- XU, Y., PENG, X., TANG, C. Y., FU, Q. S. & NIE, S. 2010. Effect of draw solution concentration and operating conditions on forward osmosis and pressure retarded osmosis performance in a spiral wound module. *Journal of Membrane Science*, 348, 298-309.
- XUE, W., TOBINO, T., NAKAJIMA, F. & YAMAMOTO, K. 2015. Seawater-driven forward osmosis for enriching nitrogen and phosphorous in treated municipal wastewater: Effect of membrane properties and feed solution chemistry. *Water research*, 69, 120-130.
- YAELI, J. 1992. Method and apparatus for processing liquid solutions of suspensions particularly useful in the desalination of saline water. Google Patents.
- YANG, Q., LEI, J., SUN, D. D. & CHEN, D. 2015. Forward Osmosis Membranes for Water Reclamation. *Separation & Purification Reviews*.

- YANG, Q., LEI, J., SUN, D. D. & CHEN, D. 2016. Forward osmosis membranes for water reclamation. *Separation & Purification Reviews*, 45, 93-107.
- YANG, Q., WANG, K. Y. & CHUNG, T.-S. 2009. Dual-layer hollow fibers with enhanced flux as novel forward osmosis membranes for water production. *Environmental science & technology*, 43, 2800-2805.
- YONG, J. S., PHILLIP, W. A. & ELIMELECH, M. 2012. Coupled reverse draw solute permeation and water flux in forward osmosis with neutral draw solutes. *Journal of Membrane Science*, 392, 9-17.
- YOON, H., BAEK, Y., YU, J. & YOON, J. 2013. Biofouling occurrence process and its control in the forward osmosis. *Desalination*, 325, 30-36.
- ZHANG, F., BRASTAD, K. S. & HE, Z. 2011. Integrating forward osmosis into microbial fuel cells for wastewater treatment, water extraction and bioelectricity generation. *Environmental science & technology*, 45, 6690-6696.
- ZHANG, J., GIANNIS, A., CHANG, V. W., NG, B. J. & WANG, J.-Y. 2013. Adaptation of urine source separation in tropical cities: Process optimization and odor mitigation. *Journal of the Air & Waste Management Association*, 63, 472-481.
- ZHANG, J., SHE, Q., CHANG, V. W., TANG, C. Y. & WEBSTER, R. D. 2014. Mining Nutrients (N, K, P) from Urban Source-Separated Urine by Forward Osmosis Dewatering. *Environmental science & technology*, 48, 3386-3394.
- ZHAO, S. & ZOU, L. 2011. Effects of working temperature on separation performance, membrane scaling and cleaning in forward osmosis desalination. *Desalination*, 278, 157-164.
- ZHAO, S., ZOU, L. & MULCAHY, D. 2011. Effects of membrane orientation on process performance in forward osmosis applications. *Journal of membrane science*, 382, 308-315.
- ZHAO, S., ZOU, L., TANG, C. Y. & MULCAHY, D. 2012. Recent developments in forward osmosis: opportunities and challenges. *Journal of Membrane Science*, 396, 1-21.
- ZOU, S., GU, Y., XIAO, D. & TANG, C. Y. 2011. The role of physical and chemical parameters on forward osmosis membrane fouling during algae separation. *Journal of Membrane Science*, 366, 356-362.
- ZOU, S. & HE, Z. 2016. Enhancing wastewater reuse by forward osmosis with self-diluted commercial fertilizers as draw solutes. *Water research*, 99, 235-243.
- ZUMA, L., VELKUSHANOVA, K. & BUCKLEY, C. 2015. Chemical and thermal properties of VIP latrine sludge. *Water SA*, 41, 534-540.

APPENDICES

APPENDIX A: STANDARD OPERATING PROCEDURE

This Standard Operating Procedure (SOP) was developed by Albert Muzhingi and the Pollution Research Group (PRG) team to ensure the proper operation and maintenance of the FO system used during the current study.

A.1 Purpose

This manual is intended to cover safety procedures associated with operation of the FO rig as well as a description of general system operation and maintenance. General operational procedures including start up, shut down, and cleaning of the system are included along with disposal suggestions for waste products generated.

A.2 SAFETY

A.2.1 Personnel Protection

Safety glasses are required at all times when working in the laboratory. Prior to operating equipment, approval must be granted by the lab manager. Proper training is required prior to use to ensure the safety of all personnel as well as to avoid damage to the system. When handling urine and ammonium bicarbonate be sure to observe appropriate precautions such as the use of gloves, splash goggles, laboratory coat, dust respirator. Be sure to use an approved/certified respirator or equivalent and thorough hand washing. Be cautious of water around the pumps. Leaks should be checked out all the time to avoid spillages of urine and ammonium bicarbonate around the FO rig. Be sure to clean up any spills immediately and turn off system if necessary to avoid shock. When in doubt, Ask! Or consult the Materials and Safety Data Sheet(MSDS) attached.

A.3 WASTE DISPOSAL

The disposal of hazardous wastes should be done in such a manner that is consistent with all PRG hazardous waste disposal requirements. A full description of the requirements can be found online at <http://prg.ukzn.ac.za/laboratory-facilities>.

A.4 SYSTEM SET-UP AND OPERATION

The FO system at PRG was designed and constructed with the intention of being operated in the laboratory. NaCl was initially used as the feed solution to mimic the urine based on the osmotic pressure. The latter experiments involved the use of stored hydrolysed urine as the feed solution and ammonium bicarbonate as the draw solution.

This section describes the system setup used to test the FO of urine using ammonium bicarbonate as the draw solution.

Before operating the system, the following should be determined and checked:

1. Determine what concentration of draw solution that should be used. Check the starting volumes of both the draw and feed solution. In all experiments performed for this thesis a starting volume of 1 L was used for both the draw and feed solution.
2. Inspect all connectors to ensure all tubing is in place.
3. Locate an external water source to use for rinsing the system before and after the experiment. A container for draining water from the system during the rinsing is also necessary.

Operation of the System

1. Before beginning the test, flush the system for two minutes prior to beginning lab experiment.
2. To start the system, first start the feed stream pump and then turn on the draw stream pump. Follow this same procedure to turn the pumps off, first stopping the draw stream pump, waiting for 30 seconds, and stopping the feed stream pump.
3. Adjust the flow rate to the desired flow, maintaining a lower draw stream pressure at all times.
4. When finishing an experiment, follow proper cleaning procedures as outlined in the following sections.

*Note: The pressure in the feed stream (side ports) should always be higher than the pressure in the draw stream (end ports). Do not turn on the draw stream pump unless the feed stream pump is already operating.

A.5 CLEANING AND STORAGE

Membranes are delicate and expensive pieces of equipment and they should be accorded the care they deserve. The membrane should be flushed with water for 15 minutes after every experiment. If the membrane is to be used further, drain all the water and close the plugs. If the experiment is not expected to continue follow the standard cleaning procedure to be sure that the membranes are clean for storage.

A.5.1 Standard Cleaning Procedure

The following procedure should be used for cleaning the membrane system prior to storage:

1. Make sure both pumps are turned off (draw stream pump should be turned off first)
2. Drain any remaining solution from the membrane cell. Be sure to properly dispose of any hazardous waste.
3. Rinse the membrane cell, check if all channels are clear of any particulates. Fill both the feed and draw solution tanks with 1 L of water.
4. Make sure that all the tubings are functioning properly. It is important not to run the pumps dry as this can damage the pumps.
5. Turn on the feed solution pump and then the draw solution pump.
6. Circulate the system for five minutes.
7. Turn off the draw solution pump and then the feed solution pump.
8. Empty the reservoirs into a waste reservoir for proper disposal.

A.6.1 Fouling Cleaning Procedure

Regular cleaning should be done to minimize the effect of fouling on the membrane. If the flux decrease over time is not reversed with the standard cleaning procedure, fouling may be occurring.

Circulation of deionised on both sides of the membrane should be utilised as a cleaning procedure.

For further fouling analysis an osmotic backwash is recommended as described in section Chapter 3 (Elimelech & Mi, 2009) showed that increasing the velocity of water can mitigate the effects of fouling.

The following SOPs were utilised in measuring the concentrations of the following: Total Nitrogen, Total phosphate, Chloride, MP AES (sodium, potassium, magnesium and calcium) , Osmolality and COD.

- **Standard Operation Procedure – Osmolality**

1. Scope and Application

The Osmomat 3000 device is a non-invasive in-vitro (in an artificial environment rather than inside a living organism, e.g. in a test tube) diagnostic product used to determine the osmolality of aqueous solutions.

- Only use the device to measure aqueous solutions
- Never measure organic, saturated, or highly viscous solutions
- Only use accessories and consumable supplied by Gonotec for measurements.

2. Summary

Osmolality

The device measures the total osmolality of any aqueous solution. The total osmolality indicates the concentration of all osmotically active substances (such as salts, dextrose, proteins) per kilogram of water.

The osmolality is specified in mOsmo/kg.

The device determines the total osmolality of the sample solution based on the freezing point depression.

The freezing point of distilled water and an aqueous solution are measured and compared. The osmolality of any solution is determined using a linear function by 2 or 3 point calibration.

Freezing point depression

The freezing point of a solution is depressed by adding soluble or mixable substances.

The freezing points of pure water and a solution are measured and compared. Whereas water has a freezing point of 0 °C, a solution with saline concentration of 1osmol/kg has a freezing point of -1.858°C. That means that one mol of a given non-dissociated substance (6.023×10^{23} parts diluted in one kilogram of water) lowers the freezing point of a solution by 1.858 °C.

The following definitions are used in calculating osmolality:

$C_{osm} = \Delta T / K$	C_{osm} =osmolality[osmol/kg]
	T =freezing point depression[°C]
	K =1.858 °C kg/osmol freezing point constant

3. Interferences

- Never leave bottles of Standard solution uncapped, as prolonged exposure to the atmosphere will affect the solution's concentration.

4. Sampling

- Most reliable results are obtained on fresh samples

5. Safety Precautions

- Always use safety goggles, gloves and laboratory coat while working in laboratory
- Use 70% ethanol to disinfect work area.

6. Apparatus



Gonotec Osmomat 3000

1. Touchscreen
2. Upper cooling system (behind movable elevator cover)
3. Thermistor probe with measuring vessel
4. Lower cooling system
5. Elevator
6. Printer

7. Reagents/Materials

- Soft paper towel
- Micropipette(50uL)
- Gonotec measuring vessel
- Filtered/diluted sample.

8. Sample Preparation

Faecal Sludge:

- Weigh out 2g of well mixed faecal sludge sample.
- Dilute sample with 5ml distilled water and votex.
- Centrifuge for 10min at 5000rpm.
- Analyze the supernatant.

Urine:

- No dilutions are required for urine samples.
- The sample is centrifuged for 10 mins at 5000rpms.
- Analyze the supernatant.

9. Procedure

1. Switch on the Osmomat on the rear side using the on/off switch.
2. Clean the thermistor probe using a soft wet then dry paper towel.
3. Press 'measure' on the start menu.
4. Wait until ice forms on the initiation needle. After successful ice formation, the menu for calibration or the measurement menu is displayed.

Calibration

The device is calibrated using a 3-point calibration method (using distilled water and 2 calibration standards).

- Clean thermistor probe using a soft wet the dry paper towel.
- Follow the instructions on the touch screen.
- Pipette 50ul distilled water into a cleaned measuring vessel.
- Click the measuring vessel on the thermistor probe with cove facing front.

- Slide elevator down with both hands. Zero-point calibration starts automatically. Pay attention to the display on the screen.
- Move elevator up with both hands once the first measurement is complete.
- Slide the elevator up with both hands.
- Remove measuring vessel from thermistor probe.
- Dispose the measuring vessel and sample into a waste beaker.
- Clean the thermistor probe with a wet then dry soft paper towel. Failure to clean the thermistor probe immediately after measurement could result in carryover and incorrect measurement results.
- Following successful zero-point measurement, press "1. Standard to start calibration using the first calibration standard.
- Continue the calibration with Standard 2 then start the sample measurements.

Measurement

5. **Press 'measure'** the measurement menu opens.
6. Pipette a sample volume of 50ul into an unused and clean measurement vessel (do not reuse vessels).
7. The sample must be pipetted without any air bubbles.
8. Click the measuring vessel on the thermistor probe with the cover facing front.
9. Press 'single sample' and enter the sample ID using the virtual key.
10. Slide the elevator down using both hands.
11. The measurement result then displays on the touchscreen.
12. Slide the elevator up with both hands.
13. Remove measuring vessel from thermistor probe.
14. Dispose the measuring vessel and sample into a waste beaker.
15. Clean the thermistor probe with a wet then dry soft paper towel. Failure to clean the thermistor probe immediately after measurement could result in carryover and incorrect measurement results.

Shut down

1. **Power down the device using the on/off switch on the rear side.**
2. **Click a measuring vessel on to the thermistor probe.**
3. **Wipe device using a moistened paper towel and cover with protective sleeve.**

- **Standard Operation Procedure – Microwave Plasma Atomic Emission Spectrometer**

1. Scope and Application

Operation of the Agilent 4100 MP-AES involves the use of compressed air, high microwave energy and hazardous materials including corrosive fluids and flammable liquids. The plasma is extremely hot (about 6000 °C) and operates using high levels of microwave energy. The plasma emits high intensity light. The microwave excitation assembly is designed to reduce microwave radiation to safe levels while still allowing easy installation of the torch and viewing of the plasma.

The various indicator lights are color coded to represent the status of the instrument.

A green light indicates the instrument is in normal/standby mode

An orange light indicates that a potential hazard is present

A blue light indicates that operator intervention is required

A red light warns of danger or an emergency

The primary gas used is nitrogen, which is the supply gas for the plasma and nebulizer gas supply. Instrument grade quality required.

A small quantity of argon is used only in the plasma ignition cycle.

Oil free compressed air is used for the pre optics protection gas.

Pic page 24 and 25

Sample preparation

Weigh a well-mixed sample to the nearest 0.001 g in the digestion vessels. For sludge, fecal samples use between 0.1g and 0.5g. For oil or oil contaminated samples use no more than 0.25g.

If the sample cannot be well mixed and homogenized, then oven dry at 60 °C or less and then grind the sample.

Add 12ml of Aquaregia (9ml Conc nitric acid + 3ml Conc hydrochloric acid) to the samples in the digestion vessels.

Dilute each sample to 50ml (then centrifuge) and test using the MP-AES.

The microwave program is set as follows:

04:00min @ 1000w @ 90°C

05:00min @ 1000 w @ 130°C

04:00min @ 1000 w @ 190°C

10:00min @ 1000 w @ 190°C

30:00min @ 1000 w @ 30°C

Total time 1:03:00

04:00min @ 1000w @ 90°C

60:00min @ 1000 w @ 130°C

10:00min @ 1000 w @ 40°C

30:00min @ 1000 w @ 30°C

To install the MP Expert Software

Log on to the instrument computer with Administrative rights. (Username-Admin/password-3000hanover).

Insert the MP Expert Software disk in your CD Rom drive. The software will automatically start.

Follow the instructions on the screen.

Click Yes to restart the computer if prompted.

Plug the USB cable into the USB port and then into a USB port on the computer.

Once installation is complete, you will need to register your software. To start the software, click the Windows START button, Then ALL PROGRAMS>Agilent>MP Expert.

Windows START button then choose Programs>Agilent>MP Expert>MP Expert Help.

Analysis Checklist

Turn on the MP-AES and software

Prepare for analysis

Calibrate the MP-AES

Create/open a worksheet

Develop a method

Run samples

Print a report

Turning on the MP-AES and Software

Check the exhaust and intake lines are secured to the MP-AES.

Ensure the gas lines are connected to the MP-AES and the gas supplies are turned on and set to the correct pressures (4-6 bars). Switch on the nitrogen gas generator.

Check that the USB and power cables are plugged on.

Switch on the compressor and the extractor system.

Instrument

Turn on the MP-AES.

Switch on the computer(Username-Admin/password-3000hanover)

To start the MP Expert software, click the Windows start button and then choose Programs>Agilent>MP Expert>MP Expert. The main index window will appear.

Click on instrument.

Red blinking zones on the instrument model on the pc stipulates errors. Check the error bar reading on the left. Purge the instrument to remove O₂.

Click-Start Purge(1-2mins to purge)

Blinking should stop after purging.

Torch

Check that the pre optics window is clean and correctly installed and that the interlocked is engaged.

Insert the torch with the outstanding lever facing you and completely close the torch handle. Do not touch the torch-this will create hotspots. Fit the spray chamber socket to the ball joint on the base of the torch and secure using the torch clamp. Monitor pic on pc-red zones will appear if it is inserted incorrectly.

Pump

Check that all tubing on the spray chamber, nebulizer and peristaltic pump are correctly connected.

See pic.

Inlet tubing should be placed in a beaker of 500ml de-ionised water.

Go to software-Click on –Run pump icon (the lower icon).

Click on fast run (run for 2 mins) and look for a flow.

Click on Pump Off.

Check icons on left are all green.

Plasma

Ensure that the Plasma Enable Switch is in the Enable state (pushed in).

Click-Plasma On(6000 degrees celsius)

Inspect flame-must taper uniformly. Must have only the following colors (orange on the outside-pink and the blue in the middle).

Switch off if it is not correct.

Leave the plasma on while continuing with the calibration.

Preparing for Analysis

Click the Plasma button in the MP Expert software, press F5 or choose Plasma on from the arrow under the plasma button.

Ensure that the peristaltic pump is correctly set up.

Place the sample tubing from the peristaltic pump into the rinse solution and the drain tubing into the drainage vessel.

Click the pump button in the MP-Expert software and choose Normal(15rpm) from the arrow under the pump button. The pump will be initialized and the solution will begin aspirating.

It will take approx 30 mins for the MP-AES to warm up.

The plasma will take 10-15 secs to ignite. If it fails refer to the troubleshooting guide.

The plasma cannot run without the spray chamber and the nebulizer gas supply connected. Doing so will damage the torch.

MP-AES Calibration

Ensure a standard glass concentric nebulizer, a single pass spray chamber and a standard plasma torch are installed. Use white/white peristaltic pump solution tubing and blue/blue tubing for the drain. The tubing tab color denotes the tubing size.

Place the solution inlet tubing into the wavelength calibration solution and allow the sample to reach the plasma

Click the instrument button

Click Optics Calibration

Click Calibrate Instrument. The torch will be aligned then a wavelength calibration and a calibration check will be performed automatically.

After a short while, an indication of the success or failure of the calibration check will appear, as well as an indication of the wavelength offsets.

If the calibration fails, check the sample introduction system. If the system seems fine, prepare a new wavelength calibration solution and try again.

Recommended values for the settings are given on the Conditions.

Test

Tick all tests except the last.

Click RUN TEST

Export to pdf and save.

Creating/Opening a Worksheet

Click NEW from the START page or the FILE menu.

A list of recently used files will appear otherwise you may BROWSE for more.

Opening an existing worksheet

- Click OPEN from the Start page or the File menu.
- A list of recently used files will appear otherwise you may BROWSE for more. The OPEN dialog box will be displayed in this instant.
- *Choosing rack type*

Autosampler right click/Rack type/no rack



Go to bottom rack/right click/rack type/eg 11 samples.

Creating a new worksheet from a template

- Click NEW Form on the Start page or New Form Template from the file menu.
- A list of recently used files will be presented, otherwise you may BROWSE for more files. The New Form Template dialog box will be displayed in this instance.
- The Worksheet window will appear with the new worksheet loaded.

Developing a Method

1. Open a new worksheet or one from a template.
2. On the “elements” page. Select the elements from the “Element” drop down box or type the element name or symbol. Grey blocks-elements can be tested. White block-elements cannot be tested.

H	Select element  																He	
Li	Be											B	C	N	O	F	Ne	
Na	Mg											Al	Si	P	S	Cl	Ar	
K	Ca	Sc	Ti	V	Cr	Mn	Fe	Co	Ni	Cu	Zn	Ga	Ge	As	Se	Br	Kr	
Rb	Sr	Y	Zr	Nb	Mo	Tc	Ru	Rh	Pd	Ag	Cd	In	Sn	Sb	Te	I	X	
Cs	Ba	La	Hf	Ta	W	Re	Os	Ir	Pt	Au	Hg	Tl	Pb	Bi	Po	At	Rn	
Fr	Ra	Ac																
			Ce	Pr	Nd	Pm	Sm	Eu	Gd	Tb	Dy	Ho	Er	Tm	Yb	Lu		
			Th	Pa	U	Np	Pu	Am	Cm	Bk	Cf	Es	Fm	Md	No	Lr		

3. Click **ADD** or press enter on your keyboard.
4. The element will appear in the table with the primary line and default settings selected. Make any required changes to each element including selecting a different wavelength, entering additional info to the label column, selecting the type of sample.
5. Check the possible interferences. Choose wavelengths with a high intensity (expressed in count per sec-cps) and those with less interference as possible. Click on bar graph to see the different graphs.
6. Choose as many wavelengths as required (2-3 at least).
7. Click conditions to modify both common settings for the run and settings for each element. (3replicates/15rpm/15sec/stabilization time 15sec or greater).
8. Choose analyte.
9. Read time set at 3 sec (100ppb=5sec as a guide) lowppb sample=high read time and visa versa.
10. Click 'optimize' place inlet tubing in to a med to high std eg 20ppm to optimize standard. Let it rinse out a bit.
11. Click on position of std in autosampler view and the start. Do this for each std to be optimized.
12. Click on optimize- neb pressure(look for peak)/viewing position(look for peak).
13. Click sequence to specify the end of run actions, number of samples and edit the sample labels.
14. SPS3 Sample Preparation System , click the 'autosampler' tab to select the racks and probe depth if needed.

Running a sample

1. Click the ANALYSIS tab and do the following.
2. Ensure your samples are selected. This will be indicated by a check next to the RACK:Tube column. To select all solutions, select the checkbox next to the Rack:Tube title.
3. Click the RUN icon in the toolbar (or PRESS the SHIFT+F8) to begin the analysis, and follow the subsequent prompts.

Printing a report

Click Report on the toolbar or file>Report

Choose whether you want to print or preview the report or save the report as a PDF file.

Select the report template and click OPEN.

Click the PRINT button to generate a report as specified.

Turning off the Agilent 4100 MP-AES

- **Rinse the spray chamber by aspirating water for a few minutes. 1% nitric acid.**
- Extinguish the plasma by choosing 'PLASMA OFF' from the Plasma button drop down arrow or pressing SHIFT +F5 on the keyboard.
- Remove the solution tubing from the solution to prevent flooding of the spray chamber, Choose (normal-15 rpm) from the pump drop down button and pump any remaining liquid from the sample introduction system and inlet tubing. Turn the pump off when there is no more liquid flowing.

The green Plasma enable button, located in front of the MP-AES is intended for emergency only. If it is used you will have to reset the plasma enable button to 'on' position before the plasma can be re-ignited.

- To increase the pump tubing lifetime, loosen the pressure on the peristaltic pump tubing by releasing the pressure bars, and lifting the tubing out of the grooves in the tube retainer. PIC page 39
- Push up the pressure bar tensioners. This releases them from the pressure bars
- Allow the pressure bar to swing backwards
- Lift the tubing out of the grooves in the tube retainer.

Routine Maintenance

Daily:

1. Check and if necessary empty the drain vessel
2. Clean the surface of the equipment-clean all spills immediately
3. Inspect the pump tubing and replace if it has lost its elasticity,
4. Unclip the pump tubes when pump not in use.

Weekly

1. Inspect the torch for cleanliness. Clean as necessary.
2. Inspect the spray chamber for cleanliness. Clean as necessary. -soak nebulizer and spray chamber overnight in 400ml of Aquaregia which is used to remove organics.
3. 32% HCL 3:1 55% Nitric acid (300ml HCL:100ml Nitric acid)
4. Clean the nebulizer
5. Inspect the pre-optics window for cleanliness. Clean or replace as necessary

Monthly

Clean the air filter on top of your MP-AES

Perform an instrument calibration

Inspect the external gas supply system for leaks including the tubing connected to the MP-AES.

Replace any damaged leaking worn out components.

Standards Na, Mg, Ca, K. Making up 200ppm of each standard from 1000ppm.

- Take 50ml from concentrated 1000ppm individual standards and place in a 250 volumetric flask and top with distilled water to give you 200ppm.
- Combine all 4 individual standards (Na, Mg, Ca, K) to give you a stock solution of 1000ml(200ppm)
- Then make 5 different concentrations from the stock. See column 1 and 2. Concentration of the individual salts will be the concentration of the mixed standard divided by the number of salts (4).

Volume from stock(1000ppm) to dilute (mL)	Concentration of Mixed Standard (ppm)	Concentration of individual Standard (ppm)
50	200	50
200	160	40
100	80	20
50	40	10
25	20	5

- **Standard Operation Procedure – Phosphate and total P Analysis**
(Cat. No. 1.14848); (Cat. No. 1.14543)

1. Scope and Field of Application

The measurement of total phosphorus and phosphate is essential for performance studies on the struvite reactor. The phosphate concentration in influent and effluent gives indication on the performance of the reactor operation whereas the total P values (influent and effluent) demonstrate the effectiveness of the filtration material used. The recovery can be calculated based on these measurements.

(Phosphate) Measuring range 0.02 – 11.46 mg/L P₂O₅

(Total Phosphate) Measuring range 0.11 – 11.46 mg/L P₂O₅

2. Principle

In sulfuric solution orthophosphate ions react with molybdate ions to form molybdophosphoric acid. Ascorbic acid reduces this to phosphomolybdenum blue (PMB) that is determined photometrically.

3. Interferences

Sample for phosphate analysis must be pretreated by filtration (0.45µm) to remove most of turbidity (interferes with photometric measurement)

In case of total P sample mustn't be filtrated! The filtration step would remove already precipitated struvite during urine storage and thus false the analysis

In any case urine should be diluted at least 1:100 to avoid matrix effects

(Other interferences are mentioned in operational manual of test kits)

4. Sampling

Preferably collect samples in glass bottles.

5. Safety Precautions

Handle concentrated acid with cares

Always use safety goggles, gloves and laboratory coat while working in laboratory

After the analysis clean bottles and beakers with clear water keep it for drying

Dispose the used gloves after completion of analysis

Clean the hands using antiseptic soap

Disinfect hands after washing with soap

Avoid spillage and contact with skin. In the latter case use copious washings with cold water and call for medical attention.

6. Apparatus

Heating Block for Total P measurement

Spectrophotometer

Glass ware: Use acid washed glassware for determining low concentrations of orthophosphates. Phosphate contamination is common because of its absorption on glass surfaces. Avoid using commercial detergents containing phosphate. Clean all glassware with hot dilute HCL and rinse well with distilled water. Preferably reserve the glassware only for phosphate determination and after use, wash and keep filled with water until needed. If this is done, acid treatment is required only occasionally.

7. Reagents

Phosphate Test

PO₄-1 – Sulphuric Acid ($\geq 25\%$ - $< 50\%$)

PO₄-2 – Non-Hazardous

Total Phosphate Test

P-1K – Sodium nitrate ($\geq 50\%$ - $\leq 100\%$)

P-2K – Sulphuric Acid ($\geq 10\%$ - $< 15\%$)

P-3K – Non-Hazardous

8. Calibration

To check the photometric measurement system (test reagents, measurement device, handling) and the mode of working, Spectroquant® CombiCheck 10 can be used. Besides a standard solution with 0.80 mg/l PO₄-P, the CombiCheck 10 also contains an addition solution for determining sample-dependent interferences (matrix effects).

9. Sample Preparation

Fecal samples are diluted by blending 1.8g -2g sample into 1L of distilled water, as described in detail below:

Weigh out 1.8g – 2g faecal sample using an analytical balance and add to a blender with 100mL distilled water and blend.

Add blended sample to a 1L volumetric flask and dilute to 1L using distilled water.

Swirl flask until sample is completely dissolved.

Filtration

Filter paper dimensions: diameter = 47mm, pore size = 0.45 microns

Filter the diluted solution using a Buchner funnel.

Collect the filtrate for analysis.

10. Procedure

total P 1.14543.0001)

Ortho-Phosphate measurement:

Pipette 5.0 ml pretreated (diluted and filtered) sample into a test tube.

Reagent PO₄-1 5 drops Add and mix.

Reagent PO₄-2 1 level blue microspoon, add and shake vigorously until the reagent s completely dissolved

Leave to stand for 5 min (reaction time), then fill the sample into the cell, and measure in the photometer.

Total P measurement:

Digestion for the determination of total phosphorus (Wear eye protection!):

Pipette 5.0 ml pretreated sample into a reaction cell

Add 1 dose Reagent P-1K, close the cell tightly, and mix.

Heat the cell at 120 °C in the preheated thermoreactor for 30 min.

Allow the closed cell to cool to room temperature in a test-tube rack.

Do not cool with cold water!

shake the tightly closed cell vigorously after cooling.

Add 1 dose reagent P-2K, close the cell tightly, and mix.

Add 1 dose reagent P-3K, close the cell tightly, and shake vigorously until the reagent is completely dissolved.

Leave to stand for 5 min (reaction time), then measure the sample in the photometer.

.....

Sample Analysis

Note: Procedure according to Merck operational Manual for test kits (Phosphate 1.14848.0001 and total P 1.14543.0001)

Ortho-Phosphate measurement:

Pipette 8.0 mL distilled water into a test tube.

Add 0.5 mL pretreated sample with a micro-pipette and mix.

Add 0.5 mL Reagent PO4-1 with a micro-pipette and mix.

Add 1 dose Reagent PO4-2 and shake vigorously until the reagent is completely dissolved.

Leave to stand for 5min (reaction time), and then fill the sample into the cell (10-mm cuvette) and measure in the photometer.

Total P measurement:

Digestion for the determination of total phosphorus (Wear eye protection!):

Pipette 5.0 mL pretreated sample into a reaction cell.

Add 1 dose Reagent P-1K, close cell tightly, and mix.

Heat the cell at 120°C in the preheated thermoreactor for 30 min.

Allow the closed cell to cool to room temperature in a test-tube rack.

Do not cool with cold water!

Shake the tightly closed cell vigorously after cooling.

Add 1 dose Reagent P-2K, close the cell tightly, and mix.

Add 1 dose Reagent P-3K, close the cell tightly, and shake vigorously until the reagent is completely dissolved.

Leave to stand for 5 min (reaction time), then measure the sample in the photometer.

Procedure (Using Standard Solution - Reagent R-1)

Note: The error caused by the photometric measurement system and the mode of operation can be determined by means of the standard solution. This is used **without dilution** in place of the sample solution.

Basic Procedure: Proceed according to the instructions given in the package insert of the respective test kit and in the manual of the photometer used (as described in the total P measurement procedure using UD samples). In this case, however, use **undiluted reagent R-1** in place of the sample without adjusting the pH!

Detailed Procedure:

Total P measurement using a standard solution (reagent R-1):

Digestion for the determination of total phosphorus (Wear eye protection!):

Pipette 5.0 mL **undiluted reagent R-1** into a reaction cell.

Add 1 dose Reagent P-1K, close cell tightly, and mix.

Heat the cell at 120°C in the preheated thermoreactor for 30 min.

Allow the closed cell to cool to room temperature in a test-tube rack.

Do not cool with cold water!

Shake the tightly closed cell vigorously after cooling.

Add 1 dose Reagent P-2K, close the cell tightly, and mix.

Add 1 dose Reagent P-3K, close the cell tightly, and shake vigorously until the reagent is completely dissolved.

Leave to stand for 5 min (reaction time), then measure the **standard sample** in the photometer.

11. Disposal of Waste Chemicals

Dilute 10 ml into 1000ml.

Slowly add NaCO₃ until ph 6-8 is reached.
Flush down the sink with excess water.

12. Calculations

$$\text{Wet Sample Concentration (g/g)} = \frac{A}{1000} \times \frac{V}{M}$$
$$\text{Dry Sample Concentration (g/g)} = \frac{\text{Wet Sample Conc. (g/g)}}{\text{Total Solids (g/g)}}$$

Where:

A – Spectroquant Reading Concentration

V – Volume of Dilution (L)

M – Mass of Sludge used in sample preparation (g)

- Standard Operation Procedure – Nitrogen (Total) Cell Test**

(Cat. No. 1.14763)

Scope and Field of Application

Test measures the total nitrogen, in a concentration range of 10 – 150 mg/l N, of solutions with a maximum of 2% sodium chloride.

Principle

Organic and inorganic nitrogen compounds are transformed into nitrate according to Koroleff's method by treatment with an oxidizing agent in a thermoreactor. In a solution acidified with sulfuric and phosphoric acid, this nitrate reacts with 2,6-dimethylphenol (DMP) to form 4-nitro-2,6-dimethylphenol that is determined photometrically.

Interferences

Concentrations of foreign substances in mg/l or %					
Al ³⁺	1000	Hg ²⁺	1000	Surfactants	500
Ca ²⁺	1000	Mg ²⁺	1000	CSB (K-Hydrogen phthalate)	3500
Cd ²⁺	1000	Mn ²⁺	1000		
Cl ⁻	10000	Ni ²⁺	1000	Na-acetate	10 %
Cr ³⁺	100	Pb ²⁺	1000	NaCl	2 %
Cr ₂ O ₇ ²⁻	100	PO ₄ ³⁻	1000	Na ₂ SO ₄	10 %
Cu ²⁺	1000	SiO ₃ ²⁻	1000		
F ⁻	1000	Sn ²⁺	1000		
Fe ³⁺	1000	Zn ²⁺	1000		

When the quantity of reagent N-1K is doubled, the tolerable COD increases to 7000 mg/l. In the event of higher COD values false-low results are obtained.

Sampling

Preferably collect samples in glass bottles.

Analyse immediately after sampling.

Check, where necessary, the COD with the Spectroquant® COD Cell Test. In the event of COD values of more than 7000 mg/l, the sample must be diluted with distilled water.

Reclose the reagent bottles immediately after use.

Safety Precautions

Handle concentrated acid with care

Always use safety goggles, gloves and laboratory coat while working in laboratory

After the analysis clean bottles and beakers with clear water keep it for drying

Dispose the used gloves after completion of analysis

Clean the hands using antiseptic soap

Disinfect hands after washing with soap

Avoid spillage and contact with skin. In the latter case use copious washings with cold water and call for medical attention.

Apparatus

Spectroquant

Reaction cells

Thermoreactor

Pipettes

Reagents

Reagent N-1K

Reagent N-2K

Reagent N-3K

Calibration

To check the photometric measurement system (test reagent, measurement device, and handling) and the mode of working, nitrogen (total) solutions, 10.0 mg/l N, and 100 mg/l N can be used.

Procedure

Pipette 1 ml of pre-treated sample into an empty cell.

Add 9 ml of distilled water into cell and mix.

Add 1 level blue micro spoon of reagent N-1K and mix.

Add 6 drops of reagent N-2K, close cell and mix.

Heat the cell at 120 °C in the preheated thermoreactor for 1 hour. Shake the cell briefly after 10 minutes.

Pipette 1 ml of the digested solution into a reaction cell. Do not mix.

Pipette 1 ml of reagent N-3K the reaction cell, close the cell and mix. Wear eye protection and hold the cell only at the top.

Leave the hot reaction to stand for 10 min (reaction time). Do not cool with water.

Measure in the photometer

Notes on the measurement:

Analyze immediately after sampling.

Reclose the reagent bottles immediately after use.

For photometric measurement the cells must be clean. Wipe, if necessary, with a dry paper towel.

The colour of the measurement solution remains stable for 30 min after the end of the reaction time stated above. (After 60 min the measurement value would have increased by 5 %.)

Data Quality

Measurement 10 – 150 mg/l N

Standard Deviation (mg/l N) ± 1.1

Confidence Interval (mg/l N) ± 3

Sensitivity (mg/l N) 2

Accuracy (mg/l N) ± 5

Chemical Waste Disposal

- **Standard Operation Procedure – Chloride Analysis**

1. Scope and Application

The M926 Chloride analyser is used for the determination of chloride ions. It is an instrumental analogue of ‘Argentimetry’, the titrimetric methods using Silver Nitrate reagent. Like these classical methods it relies on the chemical formation of the very insoluble salt, silver chloride. The importance of chloride determination has been realized for well over a century, with many variations and changes being made to the techniques in order to improve the detectability and selectivity.

The M926 Chloride analyzer is a direct reading, digital chloride meter. It is designed for fast and accurate determinations of chloride levels in industrial samples.

Sample volume is 0.5ml and results are displayed on a digital readout in mg/L (milligrams per liter chloride) or mg%(milligram percent) salt as sodium chloride

2. Summary

An accurately measured volume of sample (0.5ml is added to an acid buffer. The analyser automatically titrates chloride ions by passing a known constant current between two silver electrodes which provides a constant generation of silver ions.

These silver ions combine with the chloride in the sample to form silver chloride, which is held in suspension by the colloid stabilizer.

During the titration period the digital readout is updated every 0.3seconds. During these periods the number of silver ions introduced into the sample combine with one-unit measurement of chloride.

When all the chloride has been precipitated as silver chloride, free silver ions begin to appear and the solution conductivity changes.

This change is detected by the detector electrodes and the readout is stopped, displaying the results directly readout in mg/L(milligrams per liter chloride) or mg%(milligram percent)salt as sodium chloride.

Another sample may now be added to the same buffer and the cycle repeated.

The digital display is held until starting another cycle, when it is automatically reset to zero.

Sample range: 10-999mg/l chloride or 2-165mg% salt.

3. Interferences

Never leave bottles of Standard solution uncapped, as prolonged exposure to the atmosphere will affect the solution’s concentration.

4. Sampling

Most reliable results are obtained on fresh samples

5. Safety Precautions

Always use safety goggles, gloves and laboratory coat while working in laboratory

Use eye and hand protection when preparing acid or handling color reagent

Prepare and keep color reagent in fume hood

6. Apparatus

Sherwood Chloride Analyser Model 926

7. Reagents

8. Sample Preparation – Fecal Sludge

‘dissolve/diluent’ the sample.

Weigh out between 1.8g and 2g of well mixed fecal sludge sample.

Place the weighed out sample into a blender with 250ml of distilled water.

Blend for 30 seconds.

Transfer the blended mixture into a volumetric flask and top up to 1L with distilled water.

Transfer the 1L solution to a plastic bottle and store in the cold room.

9. Procedure

Fill the plastic beaker, supplied, to the mark with the combined acid buffer, place the beaker on the platform and raise the platform until it locates in the up position.

Pipette 0.5ml of 200mg/l standard solution into the beaker.

Press the ‘condition’ button and wait for the condition cycle to complete.

Pipette 0.5ml of sample into beaker and press titrate button.

When the stirrer stops, note the reading on the display. If the results are required in mg% salt depress the select button to mg% salt.

Repeat 4 and 5 for further samples.

At the end of the 5th titration, the message ‘condition in 2’ will appear on the screen. If only two further samples are to be run, return to number 4. If more than two samples are to be run, continue with number 9. ‘Condition 1’ will be shown after the 6th titration.

IMPORTANT

When the 7th titration is complete any further sample added will be lost. “change buffer and condition / condition required” will be displayed on the screen and the titrate button will have no effect. Go to number 9.

If “change buffer and condition / condition required” is displayed, continue with number 9.

Lower beaker and empty out contents. Rinse with deionized water and dry with clean tissue.

If necessary, adjust the vertical position of the anode, Item 2, so that it is the same length as the other electrodes.

If more samples are to be titrated return to number 2.

When determinations are complete, remove the beaker and dry the electrodes and stirrer by blotting with a clean tissue.

10. Operating Precautions and hazards

The electrodes may go black during use; clean electrodes only if there are measurement errors.

The analyser requires a warm up period of 5 minutes to meet the stated specification.

Reproducibly accurate results are dependent on the reproducible pipetting from sample and from aqueous standard to sample. If the calibration is checked with an aqueous standard and reproducibly low results are obtained, hold up in the pipette should be suspected and a rinse out technique employed.

Samples should have low ionic strength, neutral ph and free of sulphide, sulphur dry silver halides, silver reactive substances (other than chloride), solid matter and high levels of dissolved solids.

DO NOT LEAVE ELECTRODES IMMERSSED IN REAGENTS WHEN THE INSTRUMENT IS NOT IN USE.

- **Standard Operation Procedure – Total Alkalinity**

1. Selection of Method

Alkalinity of water is its buffering capacity to neutralize quantitatively an acid to a designated pH. Alkalinity consists of the carbonate, bicarbonate and hydroxide content of the water. The measured values may include contributions from borates, phosphates or silicates if these are present. Alkalinity measures are significant in determining suitability of water for irrigation and for interpreting treatment requirements. Digester supernatant liquor has an alkalinity of about $\pm 3000\text{mg/L}$.

2. Principle

Hydroxyl ions present in a sample as a result of dissociation of hydroxides or borates react with additions of standard acid. Alkalinity thus depends on the end point pH used.

For samples containing $>50\text{ mgCaCO}_3/\text{L}$ and for samples known or suspected to contain silicates or phosphates, pH 4.5 is suggested as the equivalence point.

3. Interferences

- Silicates, phosphates and borates contribute to alkalinity measurements
- The titration/indicator method is affected by interfering colour and turbidity.
- Soaps, oily matter, suspended solids or precipitates may coat the glass electrode and cause a sluggish response.

4. Sampling

- Collect samples in polyethylene or borosilicate glass bottles.
- Fill bottles completely and cap tightly.
- Analyze waste water samples within 6 hours or store at 4°C and test within 24 hours since microbial action results in loss or gain of CO_2 .
- Avoid sample agitation and prolonged exposure to air.

5. Safety Precautions

- Always use safety goggles, gloves and laboratory coat while working in laboratory
- Use eye and hand protection when preparing acid or handling colour reagent

6. Apparatus

- Glassware: "A" grade borosilicate 50ml burette, 250ml volumetric flask, 1000ml volumetric flask, volumetric pipettes and Erlenmeyer flask.
- Analytical balance
- Drying oven
- Desiccator
- pH meter

7. Reagents

- **0.02N Sulphuric Acid**

Dissolve 0.5ml conc sulphuric acid in distilled water and dilute to 1liter.

Weigh out about 1.325g anhydrous Sodium Carbonate, previously dried at 270°C . Dissolve in distilled water and make up to 250ml in a volumetric flask- this is 0.10N. Do not keep longer than 1 week.

Titrate the sulphuric acid solution against 25ml of sodium carbonate solution using bromocresol green-methyl red mixed indicator. Calculate the normality of the sulphuric acid.

$$\text{Normality of } H_2SO_4 \text{ solution} = \frac{25 \times 0.1}{\text{Vol } H_2SO_4 \text{ used}}$$

- **Mixed Bromocresol Green- Methyl Red indicator Solution**

Mix 0.2g bromocresol green and 0.04g methyl red in 100 ml 95% ethyl alcohol .

8. Procedure

- Do not dilute, concentrate or alter sample.
- Measure 50ml of well mixed undiluted sample into a suitable Erlenmeyer flask, using a measuring cylinder.
- Add 2-3 drops mixed indicator.
- Titrate with 0.02N Sulphuric acid, observing colour change from greenish blue to dull grey.
- Prepare and titrate an indicator blank and subtract this volume from the sample titration.

9. Notes

- The end point is difficult to distinguish therefore check it periodically against a pH meter at pH 4.5.
- As alkalinity decreases below 50 mg/L $CaCO_3$, the endpoint pH increases progressively from 4.5 – 4.9 at the lower levels.
- Use the potentiometric method for end point detection, i.e. by titrating to an end point of 4.5 using a pH electrode.

10. Calculation

1ml 0.02N H_2SO_4 = 1mg $CaCO_3$

$$\text{Alkalinity (mg/L as } CaCO_3) = \frac{\text{titration} \times 1000}{\text{Vol sample}}$$

- **Standard Operation Procedure –Solids - 2540**

Introduction

Solids refer to matter suspended or dissolved in water, wastewater and fecal sludge. Solids may affect water or effluent quality adversely in a number of ways. Solids analyses are important in the control of biological and physical wastewater treatment processes and for assessing compliance with regulatory agency wastewater effluent limitations.

Total Solids is the term applied to material residue left in the vessel after evaporation of a sample and its subsequent drying in an oven at a defined temperature. Total solids includes total suspended solids, the portion of solids retained by a filter and total dissolved solids, the portion that passes through the filter of 2.0µm or smaller. Fixed Solids, is the term applied to residue of total, suspended or dissolved solids after heating to dryness for a specified time at a specified temperature. The weight loss on ignition is called volatile solids.

Total Solids Dried at 103-105°C

1. Scope and Field of Application

Total Solids are determined in a wide variety of liquid and semi-liquid materials. These include portable waters, domestic and industrial waters, polluted waters and faecal sludge produced from treatment processes. It is of particular importance for the efficient operation of a treatment plant.

A known volume of well-mixed sample is evaporated to dryness in a porcelain crucible in a hot air oven at 105°C, the solids remaining are cooled and weighed. The residual material in the crucible is classified as total solids, and may consist of organic, inorganic, dissolved, suspended or volatile matter

2. Interferences

- Highly mineralized water with a significant concentration of calcium, magnesium, chloride and sulphate may be hygroscopic and require prolonged drying, proper desiccation and rapid weighing.
- Exclude large, floating particles from the sample if it is determined that their inclusion is not desired in the final result.
- Disperse visible floating oil and grease with a blender before withdrawing sample portion for analysis because excessive residue in the dish may form a water-trapping crust.

3. Sampling

- Mix the sample well to suspend solids uniformly.
- Remove the test portion rapidly before any settling of solid matter occurs.
- Use a measuring cylinder and not a pipette for sludge and wastewater samples.
- Use a crucible for feces.
- Use a volume or mass of sample to ensure a measurable residue- limit sample to no more than 200mg residue
- Suitable aliquots: Liquid samples – 100ml, Sludge -30ml, Faeces 10-20g

4. Safety Precautions

- . Always use safety goggles, gloves and laboratory coat while working in laboratory
- Wear gloves suitable for withstanding high temperatures when removing crucibles from the oven.
- After the analysis clean bottles and beakers with clear water keep it for drying
- Dispose the used gloves after completion of analysis
- Clean the hands using antiseptic soap

- Disinfect hands after washing with soap
- Avoid spillage and contact with skin. In the latter case use copious washings with cold water and call for medical attention.

5. Apparatus

- 50ml capacity evaporating porcelain crucibles
- Desiccator
- Drying oven
- Analytical Balance

6. Reagents

- None

7. Calibration

- Check the temperature throughout the oven area by placing a calibrated thermometer on each shelf, after 30mins, check temperature at each level against oven setting.
- Adjust oven setting if necessary.
- If temperatures are uneven on the shelves, check insulation.

8. Procedure

Prepare Crucible

- If volatile solids are to be measured ignite clean crucible at 550°C for 1hr in the furnace. If only total solids are to be measured, heat clean crucible to 103-105°C for 1h. Store and cool dish in a desiccator until needed. Weigh immediately before use.....**W1g**

Sample Analysis

- Measure out appropriate volume (30ml) /minimum mass (10-20g) that will yield a residue between 2.5 and 200mg of a mixed sample using correct volume measuring cylinder or analytical balance.....**Vml...Wg**. Transfer quantitatively to the weighed crucible, rinsing the cylinder with small volumes of distilled water to dislodge heavy particles. Add washings to the crucible.
- Place in hot oven at 103-105°C for 24hrs.
- *Dry sample for at least 1hr in an oven 103-105°C, to desiccator to balance temperature and weigh. Repeat cycle of drying, cooling and weighing until a constant weight is obtained, or until weight change is less than 4% of previous weight or 0.5mg, whichever is less.*

Remove the next day and cool for 15 minutes and weigh.....**W2g**

9. Calculation

$$\text{Total Solids in Sample (mg/l)} = \frac{(W_2 - W_1)g \times 100\,000}{V_{\text{sample}} (ml)}$$

$$\text{Total Solids in Wet Sample (g/g)} = \frac{(W_2 - W_1)g}{W_{\text{sample}} (g)}$$

$$\text{Moisture Content (g)} = W_{\text{sample}}(g) - [(W_2 - W_1)]g$$

Total Suspended Solids Dried at 103-105°C

1. Scope and Field of Application

Suspended solids are useful determinants in the analysis of polluted, re-use and waste waters. It is used to evaluate the strength of domestic/industrial waste waters and to determine the efficiency of treatment units, such as settling tanks, biological filters, and the activated sludge. Use of glass fiber filter pads is preferred to crucibles because of the saving in filtration time and the only prior preparation necessary is drying in an oven for 30mins at 105°C.

A measured volume of well shaken is vacuum filtered through a dried pre-weighed 110mm diameter glass fiber filter. The filters and residue is dried to a constant weight at 103-105°C. The increase in weight of the filter represents the total suspended solids.

1. Interferences

- Exclude isolated large floating particles.
- Samples high in dissolved solids must be washed adequately.
- Loss in mass of the rinsed glass fiber filters must be taken into the final calculation.
- The larger the sample, the smaller the factor applied in the calculation, but avoid prolonged filtrations.

3. Sampling

- Take the sample at a point of turbulence to ensure that it is truly representative.
- Mix sample thoroughly and remove test portion rapidly before segregation occurs.
- Use appropriate volume measuring cylinder and not pipettes.

4. Safety Precautions

- Exercise care when using glassware, vacuum pumps and ovens.
- Good housekeeping and cleanliness are essential for obtaining accurate results.

5. Apparatus

- Four- place Analytical balance
- 110mm diameter funnel and flask
- Vacuum pump

6. Reagents

- Nil

7. Calibration

- The analytical balance and ovens are checked and serviced weekly.

8. Sample Preparation – Fecal Sludge

- Weigh out between 1.8g and 2g of well mixed fecal sludge sample.
- Place the weighed out sample into a blender with 250ml of distilled water.
- Blend for 30 seconds.
- Transfer the blended mixture into a volumetric flask and top up to 1L with distilled water.
- Transfer the 1L solution to a plastic bottle and store in the cold room.

9. Procedure

Dry Filter Paper

- Use 110mm glass fiber filter paper Whatman No 4(20-25um) for sludge.
- Use 20ml sample on a 40mm, 0.45um glass fiber filter for waste water and urine.(change to a 1um pore size if the dried residue is more than 200mg.
- Use a smaller pore size if the dried residue is lower than 2.5mg.
- Mark the filter paper with a pen
- Place papers on the stainless steel mess of appropriate size
- Position on top shelf in oven at 105°C for 30min .
- If volatile solids are to be measured ignite at 550 °C for 15min in a furnace.
- Transfer to desiccator
- Cool for 20 minutes before weighing

Weigh Filter Paper

- Transfer filter paper rapidly to balance
- Note mass(**W1**)grams, to fourth decimal place

Prepare for Analysis

- Place filter pare into a 110mm diameter funnel, with the marking on the lower side
- Measure out appropriate volume to yield between 2.5 and 200mg dried residue of well mixed sample
- Place funnel into flask with side arm attached to a vacuum pump.
- Apply pump
- Wet paper with distilled water to seal edges of the paper to surface of the funnel
- Pour sample onto the filter paper, keeping sample in the middle of the paper.
- When filtration is complete. Remove paper by placing the end of a small thin spatula along the edge of the filter paper and lift slowly.
- Remove the paper with a pair of tweezers, taking care not to tear the paper.
- Fold paper twice to form a triangle enclosing sample residue. This seals the residue in the filter paper and protects it from contact with air.

Dry and Weigh

- Place triangles on a stainless steel mess
- Place in oven at 105°C for 2hrs
- Remove from oven and place in desiccator
- Cool to room temperature
- Weigh after 20 mins, as rapidly as possible
- Note mass (**W2**)grams

11. Calculation

$$\text{Total Suspended Solids (g/ml)} = \frac{(W_2 - W_1)}{V_{\text{sample}}(\text{ml})}$$

$$\text{Total Suspended Solids in Wet Sample (g/g)} = \text{TSS (g/ml)} \times \text{DF}$$

$$\text{Total Suspended Solids in Dry Sample (g/g)} = \frac{\text{TSS}_{\text{wet sample}}}{\text{Total Solids (g/g)}}$$

W₁ = weight of filter paper before oven (105°C) (g)

W₂ = weight of residue + filter paper after oven(105°C) (g)

DF = Dilution Factor

Fixed and Volatile Solids Ignited at 550°C

1. Principle

The residue from the above methods is ignited to constant weight at 550°C. The remaining solids represent the fixed total, dissolved or suspended solids while the weight lost on ignition is the volatile solids. The determination is useful in control of wastewater treatment plant operation because it offers a rough estimate of the amount of organic matter present in the solid fraction of wastewater, activated sludge and industrial wastes.

2. Interferences

- Negative errors in the volatile solids may be produced by loss of volatile matter during the drying.

2. Apparatus

- Muffle Furnace
- As above

4. Procedure

- Ignite residue from the total solids to constant weight in a muffle furnace at a temperature of 550°C.
- Have furnace up to temperature before inserting sample.
- Usually 2 hr for VIP and sludge samples, 15-20min for waste water (200mg residue)
- Let the crucible cool partially in air until most of the heat has dissipated
- Transfer to a desiccator for final cooling. Do not overload the desiccator
- Weigh dish as soon as it has cooled to balance temperature.

5. Calculation

$$\text{Volatile Solids in Wet Sample (g/g)} = \frac{(B - C)}{W_{\text{sample}}(g)}$$

$$\text{Volatile Solids in Dry Sample (g/g)} = \frac{VS_{\text{wet sample}}}{\text{Total Solids(g/g)}}$$

$$\text{Fixed Solids in Wet Sample(g/g)} = \frac{(C - D)}{W_{\text{sample}}(g)}$$

$$\text{Fixed Solids in Dry Sample(g/g)} = \frac{FS_{\text{wet sample}}}{\text{Total Solids(g/g)}}$$

B = weight of residue + crucible before ignition - 550°C (g)

C = weight of residue + crucible after ignition -550°C (g)

D = weight of crucible (g)

Forward osmosis membrane datasheet



HTI OsMem™ TFC-ES Membrane

Features:

- The OsMem™ TFC-ES Membrane is HTI's fastest and highest rejecting FO membrane.
- The OsMem™ TFC-ES Membrane is used in all spiral-wound FO elements that use TFC.
- The OsMem™ TFC-ES Membrane is cast on 40" (1-m) wide rolls.
- The OsMem™ TFC-ES Membrane coupons are shipped "dry," where vegetable-based glycerin replaces the water.

Typical FO Performance (Rejection Layer Contacting Feed):

- Water Permeation: 12 GFD (gallons per square foot each day) (20 LMH – liters per square meter each hour)
- Salt Rejection: 99.6% as defined in Test Conditions

Test Conditions: Feed: 1 gpm (4 lpm) tap water feed at 77°F (25°C) fed at the bottom into a 4" (100 mm) by 0.2" (5 mm) open channel with an initial volume of 0.40 gal (1.5 L) and an exit pressure of 10 psi (40 kPa). Draw: 20 gph (75 lph) 1 M NaCl (58.5 g/L) at the bottom at 6 psi (40 kPa) feed into a 4" (100 mm) by 0.06" (1.5 mm) channel of three 20-mil (0.51-mm) epoxy-coated permeate spacer with the bottom two oriented normal to flow and the membrane-contacting spacer parallel to the flow with an initial volume of 0.13 gal (0.5 L).
Membrane Area: 0.22 ft² (0.020 m²)
Rejection: $\{1 - [(\text{mol NaCl transferred to feed})/(\text{L water removed})]/(1 \text{ M})\}$

Typical uPRO* Performance (Rejection Layer Contacting Draw Solution):

- Water Permeation: 24 GFD (gallons per square foot each day) (40 LMH – liters per square meter each hour)
- Salt Rejection: 99.6% as defined in Test Conditions

Test Conditions: Feed: 20 gph (75 lph) tap water at the bottom at 6 psi (40 kPa) feed into a 4" (100 mm) by 0.06" (1.5 mm) channel of three 20-mil (0.51-mm) epoxy-coated permeate spacer with the bottom two oriented normal to flow and the membrane-contacting spacer mounted parallel to the flow with an initial volume of 0.26 gal (1.0 L). Draw: 1 gpm (4 lpm) 1 M NaCl (58.5 g/L) at 77°F (25°C) fed at the bottom into a 4" (100 mm) by 0.2" (5 mm) open channel with an initial volume of 0.2 gal (0.8 L) and an exit pressure of 10 psi (70 kPa).
Membrane Area: 0.22 ft² (0.020 m²)
Rejection: $\{1 - [(\text{mol NaCl transferred to feed})/(\text{L water removed})]/(1 \text{ M})\}$
***uPRO:** unpressurized Pressure Retarded Osmosis membrane orientation

HTI OsMem™ TFC-ES Membrane (page 2)



Operating Limits and Guidelines:

- | | |
|----------------------------------|--|
| • Membrane Requirements | Membrane coupons are shipped in glycerin. Should be soaked in water for 30 minutes prior to use. After glycerin extraction, membrane must be kept moist at all times. Do not allow to freeze. Exercise care in handling. |
| • Membrane Type | Thin-Film Composite (TFC) with embedded polyester screen support |
| • Maximum Operating Temperature | 160°F (71°C) |
| • Maximum Transmembrane Pressure | 10 psi (70 kPa), if supported |
| • pH Range | 2 to 11 |
| • Maximum Chlorine | <0.1 ppm |
| • Cleaning Guidelines | Use only cleaning chemicals approved for TFC RO membranes |
| • Storage Guidelines | Store out of direct sunlight with a couple mL of water in a sealed bag |

FO Membrane Notes:

The membrane is initially cast on rolls. On a roll, the rejection layer is to the inside of the roll and is the shiny side; on drying, the membrane will curl towards the rejection layer.

FO membranes behave similarly to RO membranes in that dissolved gases are not rejected well. Their ions are rejected, but the (often small) fraction that exists as a dissolved gas is not rejected. Small polar, water-soluble organics, such as urea, methanol, and ethanol, are also not rejected well.

Brief Startup Description:

If the process is being run with the draw solution contacting the rejection layer (uPRO), make sure that there is water in the cell on the supported side to draw from. Start the pump on the unsupported side. Adjust the flowrate with the inlet valve and the exit pressure to 10 psi (70 kPa) with the exit valve. Start the side with the membrane support and adjust to the desired inlet pressure of 6 psi (40 kPa). Monitor volume or weight changes, temperature, and concentrations with time.

Brief Shutdown Descriptions:

Turn off the pumps and drain the high osmotic pressure solution first. Then drain the low osmotic pressure solution. Rinsing is recommended. The membrane can be stored in the cell – preferably drained.

APPENDIX B- RAW DATA

Osmotic pressure estimation approach

The osmotic pressure of NaCl solution was calculated through the use of PHREEQ C and the Van't Hoff equation and the obtained values were compared to that obtained in literature. The use PHREEQ C enabled the calculation of the activity of water via the Pitzer correlation. The Van't Hoff equation utilised the measured osmolality. The literature values were obtained via conductivity calibration.

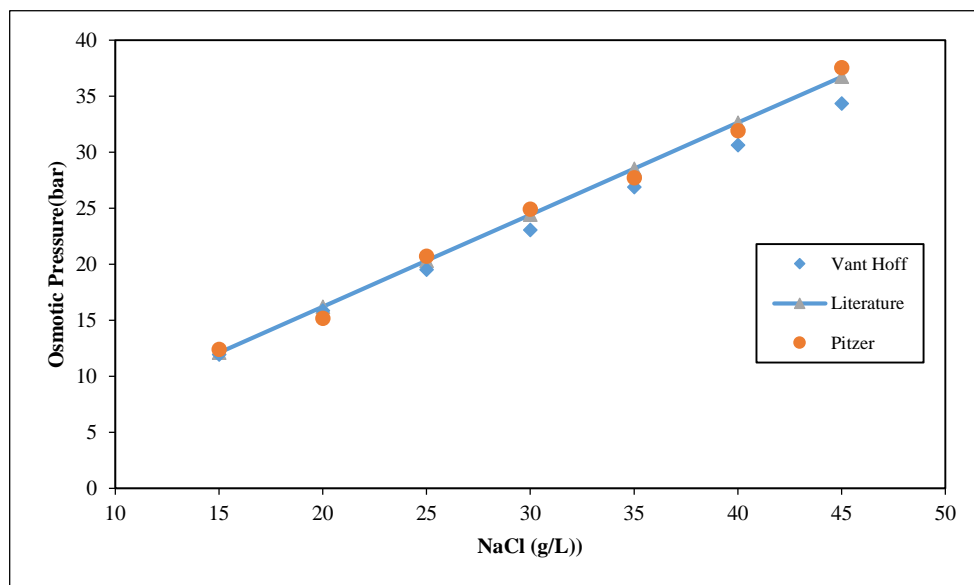

Figure 7-1: Comparison of the osmotic pressure of NaCl obtained through the use of the Van't Hoff equation, Pitzer correlation and Literature values at 25 °C

The Pitzer model is in close agreement with the literature values with a maximum relative error of 10 % over the concentration range investigated. As the concentration of NaCl increases (deviation from ideality) the Van't Hoff equation also deviates from the observed literature values.

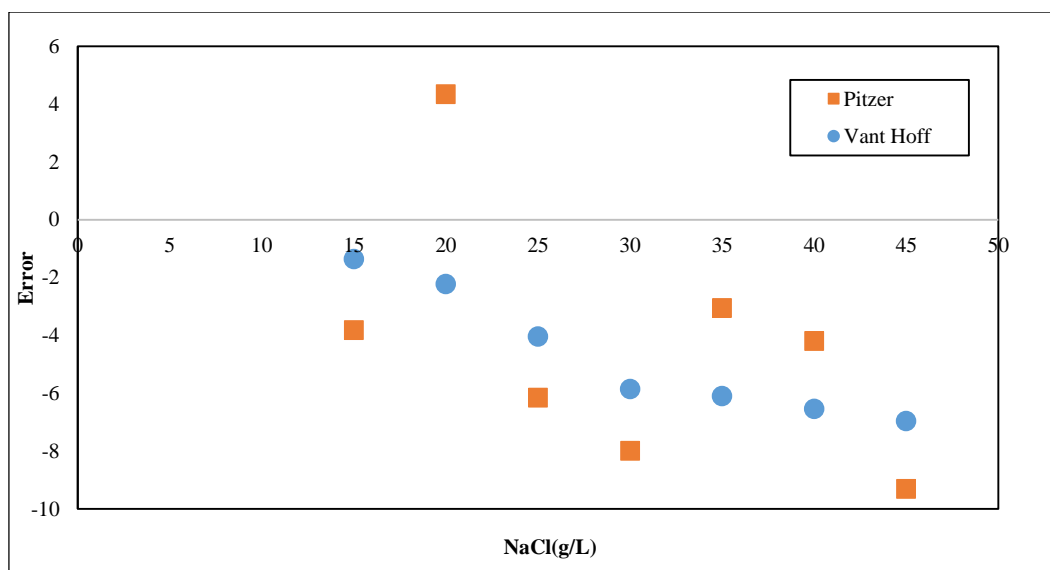

Figure 7-2: Error analysis between the values obtained through the use of the Van't Hoff and Pitzer correlation as compared to those from literature

The Van't Hoff equation was in good agreement with the literature values in calculating the osmotic pressure of ammonium bicarbonate in the range investigated as can be seen in [Figure 7-3](#).

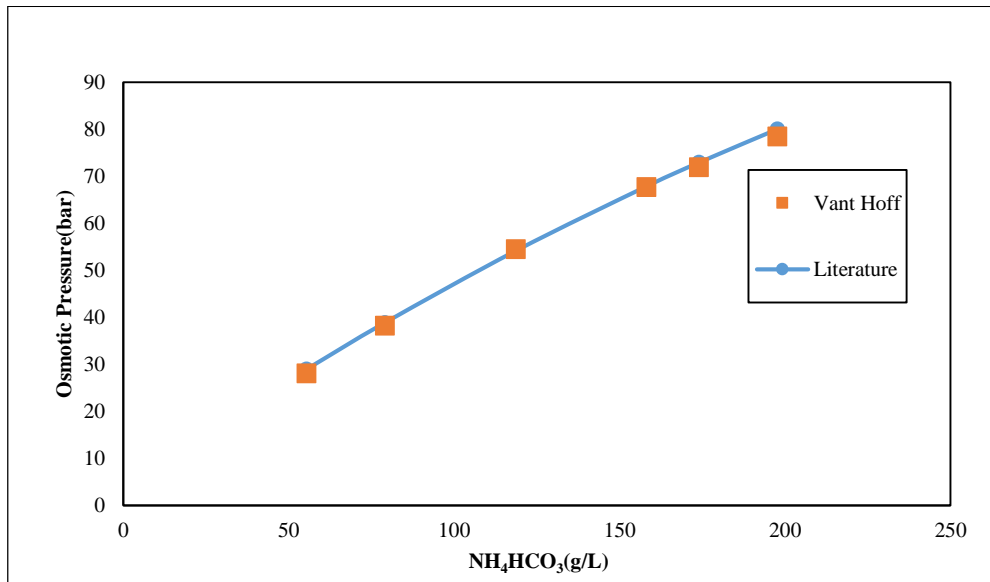

Figure 7-3: Comparison of the osmotic pressure values for ammonium bicarbonate obtained through the use of the Van't Hoff equation and literature values.

To calculate the osmotic pressure of urine individual concentrations of ions were fed into PHREEQ C and the activity of water utilised. Starting osmotic pressure of urine was also calculated based on the Van't Hoff equation that took osmolality of urine into consideration and compared to that obtained through PHREEQ C calculations. PHREEQ C and the Van't Hoff equation yielded hydrolysed urine osmotic pressures of 15.2 bar and 15.86 bar. These osmotic pressure measurements fall within the range of 14-18 bars reported by several authors (Rose et al., 2015, Zhang et al., 2014, Udert et al., 2015)

Detailed approaches adopted in calculating the above osmotic pressures be seen in Chapter 3 and the obtained full set of results can be obtained in Appendix B

This section shows the results of the calibration experiments carried out prior to proceeding with the actual experiments. The calibration enabled better understanding of the FO system.

Table B- 1: Comparison of the osmotic pressure of NaCl obtained from Literature and that obtained through the use of the Van` t Hoff Equation

NaCl(g/L)	Osmolality (mOsmo/kg)	Osmotic Pressure (bar)	Lit Osmotic Pressure(bar)	Relative Error(Osmotic Pressure)
15	482	11,94	12,10	-1,36
20	640	15,85	16,20	-2,22
25	788	19,52	20,31	-4,04
30	931	23,06	24,41	-5,86
35	1085	26,88	28,52	-6,1
40	1236	30,62	32,62	-6,54
45	1386	34,34	36,72	-6,96

Table B- 2:Comparison of the osmotic pressure of ammonium bicarbonate obtained from literature and that obtained through the use of the Van` t Hoff Equation

AB(g/L)	Osmolality (mOsmo/kg)	Osmotic Pressure (bar)	Lit Osmotic Pressure	Absolute Error(Osmotic Pressure)
55,34	1134	28,10	28,99	-3,17
79,06	1543	38,23	38,90	-1,76
118,59	2200	54,51	54,18	0,61
158,12	2733	67,71	67,89	-0,26
173,93	2905	71,97	72,93	-1,33
197,65	3167	78,46	80,03	-2,00

Table B- 3:Osmotic pressure of ammonium bicarbonate obtained from literature and that obtained through the use of PHREEQ C

NaCl(g/L)	Conc (mol/L)	Activity from (Phreeq C)	Total Alkalinity(eq/kg)	Ionic strength (mol/kg)	Osmotic Pressure (bar)	Absolute Error
15	0.26	0,991	2.121e-08	2.640e-01	12,40	-3,82
20	0.34	0,989	2.121e-08	3.469e-01	15,17	4,34
25	0.43	0,985	3.425e-08	4.411e-01	20,73	-6,16
30	0.51	0,982	5.363e-01	5.363e-01	24,91	-7,99
35	0.60	0,98	4.683e-08	6.218e-01	27,70	-3,06
40	0.68	0,977	5.258e-08	7.081e-01	31,91	-4,20
45	0.77	0,973	5.894e-08	8.063e-01	37,53	-9,31

Table B- 4: Values used to calculate the osmotic pressure of urine during the filtration process through the use of PHREEQ C. Species concentration were measured after every 2 h .

Species(t=0)	mg/L	Mr	mol/L
P	1783	31	0,0575
K	1488	39	0,0382
Mg	24,5	24	0,0010
Cl	3200	35,5	0,0901
Ca	10	40	0,0003
N	4870	14	0,3479
Na	1400	23	0,0609
CO3	3000	60	0,0500
SO4	1500	96	0,0156

Species(t=2)	mg/L	Mr	mol/L
P	1885	31	0,060806
K	1675	39	0,042949
Mg	24,5	24	0,001021
Cl	3508	35,5	0,098817
Ca	10	40	0,00025
N	5650	14	0,403571
Na	1600	23	0,069565
CO3	3000	60	0,05
SO4	1500	96	0,015625

Species(t=4)	mg/L	Mr	mol/L
P	1900	31	0,06129
K	1823	39	0,046744
Mg	24,5	24	0,001021
Cl	3882	35,5	0,109352
Ca	10	40	0,00025
N	6270	14	0,447857
Na	1700	23	0,073913
CO3	3000	60	0,05
SO4	1500	96	0,015625

Species(t=6)	mg/L	Mr	mol/L
P	1950	31	0,062903
K	1937	39	0,049667
Mg	24,5	24	0,001021
Cl	4281	35,5	0,120592
Ca	10	40	0,00025
N	6686	14	0,477571
Na	1700	23	0,073913
CO3	3000	60	0,05
SO4	1500	96	0,015625

Species(t=8)	mg/L	Mr	mol/L
P	1985	31	0,064032
K	2024	39	0,051897
Mg	24,5	24	0,001021
Cl	4517	35,5	0,127239
Ca	10	40	0,00025
N	7330	14	0,523571
Na	1850	23	0,080435
CO3	3000	60	0,05
SO4	1500	96	0,015625

Table B- 5: Measured bulk osmolality of urine and ammonium bicarbonate obtained during the filtration runs

Time	Mean(feed)			Mean(draw)			Osmolality difference(mOsmo/kg water)		
	Run 1	Run 2	Run3	Run1	Run 2	Run 3			
0	640	639	641	640	2715	2712	2719	2715	2075
1	680	678	680	679	2119	2115	2117	2117	1438
2	715	713	715	714	1924	1922	1926	1924	1210
3	760	758	762	760	1672	1670	1671	1671	911
4	813	810	812	812	1525	1532	1526	1528	716
5	843	838	842	841	1467	1466	1470	1468	627
6	884	880	883	882	1401	1400	1403	1401	519
7	907	905	906	906	1333	1330	1332	1332	426
8	949	946	950	948	1336	1336	1338	1337	388

Table B- 6: Measured bulk osmolality of urine and ammonium bicarbonate draw solution and their osmotic pressure obtained through the use of the Van't Hoff's equation

Time(h)	Osmolality (mOsmo/kg)(feed)	Osmolality (mOsmo/kg)(draw)	Osmotic Pressure feed(Bar)	Osmotic Pressure draw(Bar)	Osmolality diff(mOsmo/water)	Osmotic pressure difference(bar)
0	640	2715	15,85	67,26	2075	51,41
1	679	2117	16,82	52,45	1438	35,63
2	714	1924	17,68	47,66	1210	29,98
3	760	1671	18,82	41,40	911	22,57
4	812	1528	20,117	37,85	716	17,74
5	841	1468	20,83	36,37	627	15,53
6	882	1401	21,85	34,71	519	12,86
7	906	1332	22,44	33,00	426	10,55
8	948	1337	23,487	33,125	388	9,61

Table B- 7PHREEQ C estimation of the osmotic pressure of urine based on the individual species concentrations

Time (hr)	Osmotic Pressure (bar)	Total Alkalinity (eq kg ⁻¹)	Total Alkalinity (mol kg ⁻¹)	a _{H2O}
0	15,17	0,41	0,33	0,989
2	16,56	4.727e-01	3.532e-01	0,988
4	17,94	4.867e-01	3.547e-01	0,987
6	19,33	5.101e-01	3.837e-01	0,986
8	20,73	5.456e-01	3.978e-01	0,985

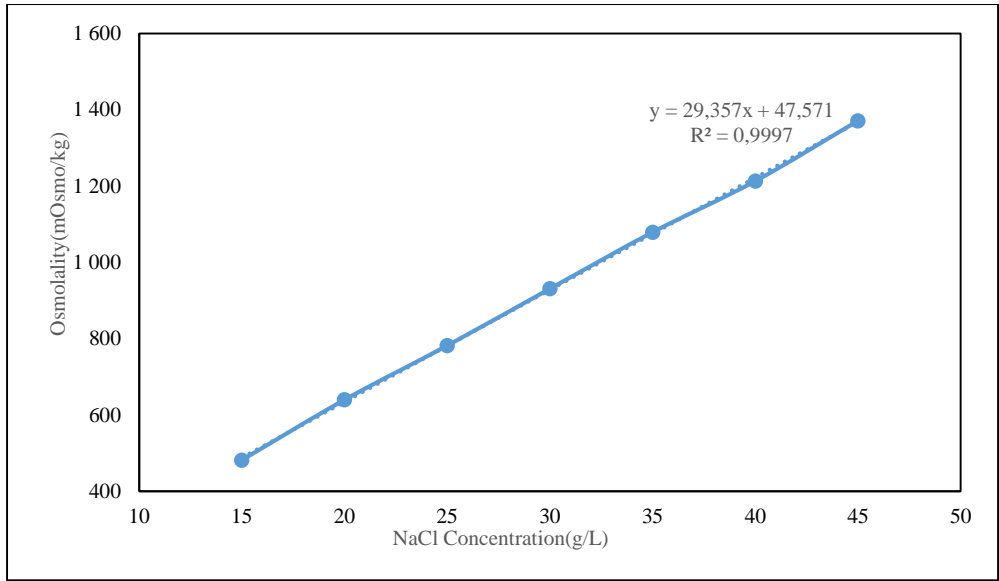

Figure B- 1: NaCl concentration vs osmolality calibration curve

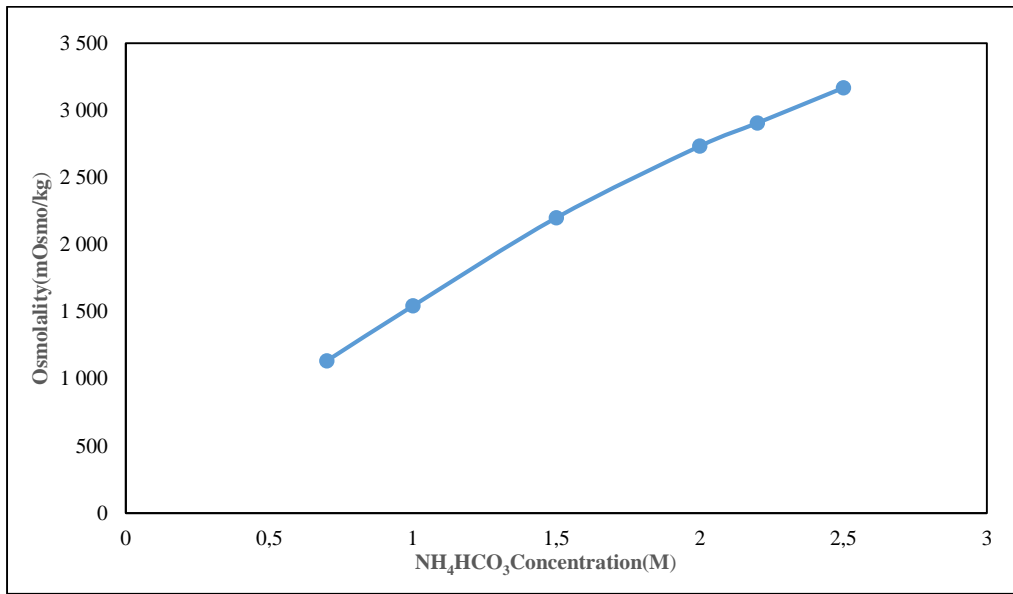

Figure B- 2: Ammonium bicarbonate concentration vs osmolality calibration curve

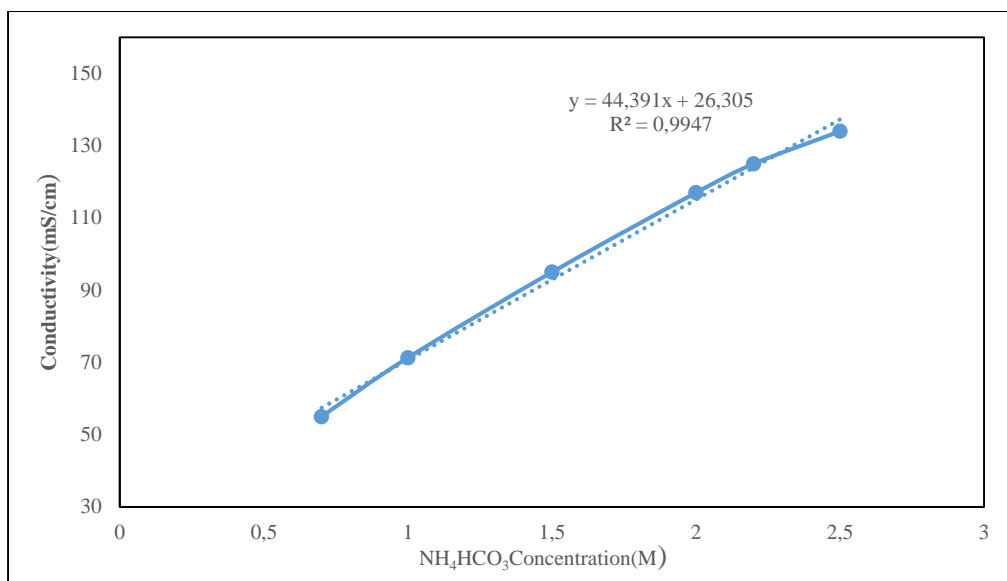

Figure B- 3:Ammonium bicarbonate conductivity calibration as a function of concentration

APPENDIX C: EXPERIMENTAL RESULTS

Table: Urine and 2 ammonium bicarbonate osmolality during the 8 h FO run together with the calculated osmolality difference ($Osmo_{draw} - Osmo_{feed}$). The osmolality difference represents the bulk difference between the feed and draw solution.

Table B- 8: Water flux as a function of ammonium bicarbonate concentration

Concentration(M) NH_4HCO_3	Flux(L/m ² .h)			
	Run 1	Run 2	Run 3	Average
0,6	1,38	1,3	1,5	1,38
1	2,4	2,36	2,5	2,42
1,5	3,34	3,42	3,23	3,33
2	4,23	4,27	4,48	4,32
2,2	4,4	4,29	4,6	4,43
2,5	4,5	4,58	5,0	4,69

Table B- 9

Time (h)	Dilution 1 , J_w (L/m ² .h)				Dilution 3 , J_w (L/m ² .h)				Dilution 1 , J_w (L/m ² .h)			
	Run 1	Run 2	Run 3	Average	Run 1	Run 2	Run 3	Average	Run 1	Run 2	Run 3	Average
0	4,93	4,31	4,53	4,59	7,81	6,80	7,83	7,48	12,86	12,80	12,81	12,82
1	4,30	3,91	4,00	4,07	6,92	7,01	6,89	6,94	11,40	11,80	11,50	11,57
2	3,96	3,57	3,78	3,77	6,41	6,59	6,55	6,52	10,55	10,20	10,40	10,38
3	3,46	3,43	3,50	3,46	5,89	5,87	5,90	5,89	9,69	9,50	9,30	9,50
4	3,06	3,19	3,22	3,15	5,36	5,31	5,29	5,32	8,83	8,70	8,73	8,75
5	2,80	2,69	2,82	2,77	4,71	4,71	4,60	4,67	7,75	7,90	7,86	7,84
6	2,49	2,56	2,62	2,56	4,35	4,40	4,18	4,31	7,16	6,80	7,45	7,14
7	2,16	2,24	2,35	2,25	3,83	3,50	3,90	3,74	6,31	6,36	6,45	6,37
8	1,98	2,06	2,17	2,07	3,52	3,52	3,45	3,50	5,79	4,90	4,60	5,10

Table B- 10: during the 8 h run with stored urine as the feed solution and 2 M ammonium bicarbonate as the draw solution

Run 1	Time(h)	V (feed)	V(ds)	Vw(t)	Na (feed)	Na (permeate) mg/L	Cs(t)	Rejections	pH feed	conductivity (feed)(mS/cm)	pH (ds)	conductivity (ds)(mS/cm)
	0	1007	1000		1400	0		1	7,25	32,9	7,47	117
	2	867	1140	140	1600	59	480,43	0,69	7,65	37,55	7,83	110
	4	762	1245	105	1700	109	651,86	0,61	8,25	42,2	8,01	103
	6	678	1329	84	1800	155	836,786	0,53	8,53	46,85	8,15	96
	8	620	1387	58	1850	200	1231,12	0,33	8,65	51,55	8,24	89
Run 1	Time	V(feed)	V (ds)	Vw(t)	Cl (feed)mg/L	Cl (permeate)	Cs(t)	Rejections	pH feed	conductivity (feed)	pH (ds)	conductivity (ds)(mS/cm)
	0	1007	1000		3100	0		1	7,25	32,9	7,47	117
	2	867	1140	140	3508	65	529,28	0,84	7,65	37,55	7,83	110
	4	762	1245	105	3882	120	717,14	0,81	8,25	42,2	8,01	103
	6	678	1329	84	4281	170	911,07	0,78	8,53	46,85	8,15	96
	8	620	1387	58	4517	219	1341,78	0,70	8,65	51,55	8,24	89
Run 1	Time	V(feed)	V(ds)	Vw(t)	P (feed)	P (permeate)	Cs(t)	Rejections	pH feed	conductivity (feed)	pH (ds)	conductivity (ds)(mS/cm)
	0	1007	1000		1800	0			7,25	32,9	7,47	117
	2	867	1140	140	1885	13	105,85	0,94	7,65	37,55	7,83	110
	4	762	1245	105	1900	24,3	146,98	0,92	8,25	42,2	8,01	103
	6	678	1329	84	1870	35	193,58	0,89	8,53	46,85	8,15	96
	8	620	1387	58	1985	46	298,05	0,84	8,65	51,55	8,24	89
Run 1	Time	V(feed)	V(ds)	Vw(t)	TN (feed)	TN (permeate)	Cs(t)	Rejections	pH feed	conductivity (feed)	pH (ds)	conductivity (ds)(mS/cm)
	0	1007	1000		4980	0			7,25	32,9	7,47	117
	2	867	1140	140	5650	100	814,28	0,85	7,65	37,55	7,83	110
	4	762	1245	105	6270	184,5	1101,93	0,82	8,25	42,2	8,01	103
	6	678	1329	84	6886	261	1394,84	0,79	8,53	46,85	8,15	96
	8	620	1387	58	7330	335,6	2044,97	0,72	8,65	51,55	8,24	89
Run 1	Time	V (feed)	V (ds)	Vw(t)	K (feed)	K (permeate)	Cs(t)	Rejections	pH feed	conductivity (feed)	pH (ds)	conductivity (ds)(mS/cm)
	0	1007	1000		1500	0			7,25	32,9	7,47	117
	2	867	1140	140	1675	55	447,85	0,73	7,65	37,55	7,83	110
	4	762	1245	105	1823	102	612,28	0,66	8,25	42,2	8,01	103
	6	678	1329	84	1937	145	782,32	0,59	8,53	46,85	8,15	96
	8	620	1387	58	2024	187	1149,38	0,43	8,65	51,55	8,24	89

Total suspended solids of raw, uncentrifuged urine, after centrifugation and after FO filtration. Rejections of TSS by both centrifugation and FO are compared

	Run 1	Run2	Run 3	Average
Uncentrifuged	323	325	320	322,67
Centrifuged	205	206	220	210,33
Uncentrifuged	323	325	320	322,67
After FO	3	2	0	1,68

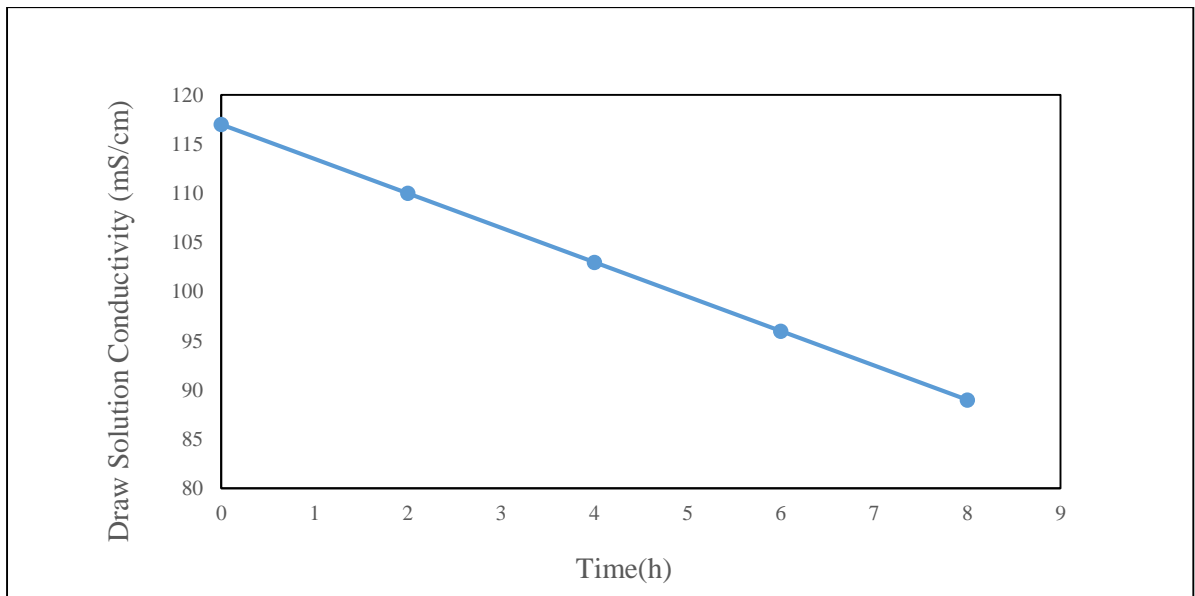
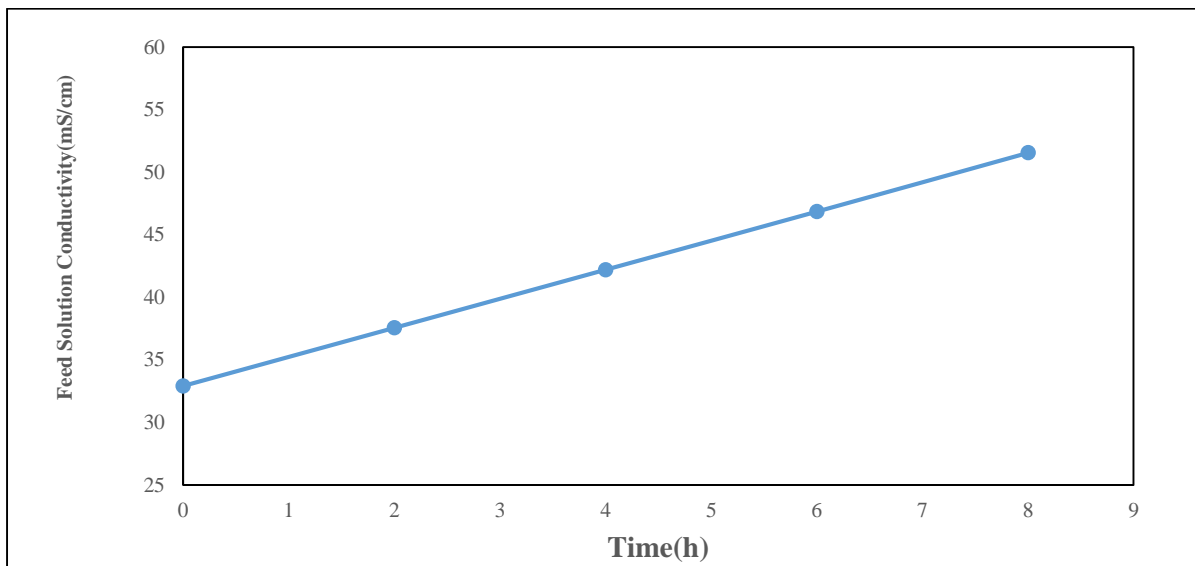

Fouling analysis, showing flux of the fresh membrane(J_0), after FO(J_1), and after cleaning (J_2) with deionised water as the feed solution and 2 M NH_4HCO_3 as the draw solution. The membrane was operated in AL-FS mode with the feed and draw solution temperature maintained at $22 \pm 0.5^\circ\text{C}$.

Time(mins)	Fresh membrane, J_0 (L/m ² .h)	After FO Flux, J_1 (L/m ² .h)	After cleaning flux, J_2 (L/m ² .h)
0	9,37	8,24	9,16
3	8,69	7,73	7,77
6	8,77	7,57	9,27
9	8,69	7,46	8,77
12	8,47	7,24	8,64
15	8,47	7,31	8,71
18	8,24	7,39	8,73
21	7,60	7,23	8,63
24	8,09	7,17	8,66
27	8,07	7,17	8,54
30	8,09	7,21	8,61
33	7,96	7,11	8,57
36	7,93	7,24	8,53
39	7,99	7,40	8,56
42	7,96	6,86	8,57
45	8,06	7,11	8,50
48	7,99	7,07	8,23
51	7,89	7,17	8,51
54	7,94	7,14	8,37
57	7,99	7,03	8,43
60	7,83	7,04	8,37
63	7,81	7,10	8,40
66	7,79	7,03	8,21
69	7,79	7,01	8,27
72	7,51	7,03	8,27
75	7,71	6,97	8,27
78	7,69	7,03	8,23
81	7,69	7,00	7,89
84	7,69	6,96	8,17
87	7,70	6,94	7,96
90	7,57	6,91	8,10
93	7,66	6,93	7,99
96	7,53	6,89	7,96
99	7,49	6,90	8,04
102	7,46	6,81	7,91
105	7,36	6,93	7,84
108	7,43	6,80	7,70
111	7,44	6,86	7,49
114	7,24	6,84	7,76
117	7,37	6,73	7,61
120	7,36	6,81	7,73
123	7,37	6,76	7,49
126	7,21	6,74	7,59
129	7,33	6,71	7,50
132	7,30	6,71	7,61
135	7,11	6,71	7,60

APPENDIX D: DERIVATION OF THE MASS BALANCE EQUATION

Solute flux can be given by equation which expresses it in terms of water flux and permeate concentration

$$J_S = J_w \times C_{p,i} \quad (D.1)$$

Where J_S = solute flux (g/m².L)

J_w = water flux(L/m².h)

$C_{p,i}$ = solute concentration in the permeate(g/L)

Solute rejections expressed in terms of permeate and feed concentration is given by

$$R = 1 - \frac{C_{p,i}}{C_{f,i}} \quad (D.2)$$

Where R = solute rejection

$C_{f,i}$ = solute concentration in the feed (g/L)

Solving for permeate concentration in Equation D2 gives Equation D3

$$C_{p,i} = C_{f,i}(1 - R) \quad (D.3)$$

The solute flux represents the mass of solute that moves across the membrane per unit area of the membrane per unit of time, which can be expressed by Equation D4

$$J_S = \frac{1}{A} \frac{dm_i}{dt} \quad (D.4)$$

where A = effective filtration area(m²)

Equating Equation D4 and Equation D1 gives

$$J_S = \frac{1}{A} \frac{dm_i}{dt} = J_w \times C_{p,i} = J_w \times C_{f,i}(1 - R) \quad (D.5)$$

Where $\frac{dm_i}{dt}$ = solute change in mass with time

Rewriting Equation D5 gives Equation D6

$$\frac{dm_i}{dt} = J_w \times C_{f,i} \times A(1 - R) \quad (D.6)$$

APPENDIX E: MATLAB CODE FOR FRAMEWORK DEVELOPMENT

```

clear all

global data_flux data_t pt init_mas m_data dat_con data_volfeed a1 a2 a3 a4 a5 b1 b2 b3 b4 b5

% 1 - Phosphates(FD)    % 4 - Sodium(FD)
% 2 - Total Nitrogen(FD) % 5 - Chloride(FD)
% 3 - Potassium(FD)

% Data on feed and draw solution concentrations (P, N, K, Na, Cl)
t = [0 2 4 6 8]; % Time [hr] ;
dat_con = [1800 2055 2320 2581 2790; 4980 5650 6270 6886 7330; 1500 1675 1823 1937 2024; 1400 1600 1700 1800 1850; 3100 3508 3882
4281 4517;...
0.01 13 24.3 35 46; 0.01 100 184.5 261 335.6; 0.01 55 102 145 187; 0.01 59 109 155 200; 0.01 65 120 170 219]'; % concentration of solutes
on feed and draw side.

dat_Drwcon_Cl = [8 308 512 744 978]; % Data on concentration of chloride on the draw side [mg/L]
data_volfeed = [1008.16 870.3 765.95 683.18 619.03]; % Volume of feed solution with time [mL]
data_voldraw = [1000 1137.86 1242.21 1324.98 1389.13]; % Volume of draw solution with time [mL]

% Initial concentrations
init_mas = zeros (10,1) ;
init_mas (1) = 1800 ; % Phosphates (FD) [mg]
init_mas (2) = 4980 ; % Total Nitrogen (FD) [mg]
init_mas (3) = 1500 ; % Potassium (FD) [mg]
init_mas (4) = 1400 ; % Sodium (FD) [mg]
init_mas (5) = 3100 ; % Chloride (FD) [mg]
init_mas (6) = 0.01 ; % Phosphates (DS) [mg]
init_mas (7) = 0.01 ; % Total Nitrogen (DS) [mg]
init_mas (8) = 0.01 ; % Potassium (DS) [mg]
init_mas (9) = 0.01 ; % Sodium (DS) [mg]
init_mas (10) = 0.01 ; % Chloride (DS) [mg]
init_mas (11) = 1 ; % Volume of water [L]

% Rejections
%k_init = [1-0.9 1-0.7 1-0.6 1-0.6 1-0.8] ;
k_init = [-0.09 -8 -10 -5 -5 3 61 77 42 42 80 -31 -71 -16 4];
options = optimset('TolX', 1e-8);
k = fmincon(@Objective_fnc_FO, k_init, [],[],[],[],[1 1 1 1 1 1 1 1 1], [5 20 20 10 10 100 50 50 50 50]);
%K_rej = fmincon (@Objective_fnc_FO, k_init,[],[],[],[],[0 0 0 0 0],[1 1 1 1 1]);
%Rej = (1 - K_rej) * 100; % [%]
%disp(Rej);
[t, m] = ode45('Solutflux', t, init_mas) ;
v_feed = m(:,11);
v_draw = 1 + (1-v_feed);

% Calculating concentration on feed side
c_FD_P = m(:,1) ./ v_feed ; % [mg/L]
c_FD_N = m(:,2) ./ v_feed ; % [mg/L]
c_FD_K = m(:,3) ./ v_feed ; % [mg/L]
c_FD_Na = m(:,4) ./ v_feed ; % [mg/L]
c_FD_Cl = m(:,5) ./ v_feed ; % [mg/L]

% Concentration of solutes on the draw solution side
c_DS_P = m(:,6) ./ v_draw ; % [mg/L]
c_DS_N = m(:,7) ./ v_draw ; % [mg/L]
c_DS_K = m(:,8) ./ v_draw ; % [mg/L]
c_DS_Na = m(:,9) ./ v_draw ; % [mg/L]
c_DS_Cl = m(:,10) ./ v_draw ; % [mg/L]

% Simulation of species concentration on the feed solution side
figure(1);
hold on
plot(v_draw, c_FD_P, 'r', v_draw, c_FD_N, 'b', v_draw, c_FD_K, 'g', v_draw, c_FD_Na, 'm', v_draw, c_FD_Cl, 'k') ;
plot (v_draw, dat_con(:,1:5), 'd') ; % Data plotting of concentration of solute in feed solution
ylabel ('Concentration of species(mg/L)') ;
xlabel ('Time (hr)') ;
legend ('Phosphates', 'Total Nitrogen', 'Potassium', 'Sodium', 'Chlorides', 'Data Phosphates', 'Data Total Nitrogen', 'Data Potassium', 'Data
Sodium', 'Data Chlorides') ;
title ('Concentration profile of species in feed solution') ;
hold off

```

```

% Simulation of species concentration on the draw solution side
figure(2);
hold on
plot(v_draw, c_DS_P,'s', v_draw, c_DS_N,'s', v_draw, c_DS_K,'s', v_draw, c_DS_Na,'s', v_draw, c_DS_Cl,'s');
plot(v_draw, dat_con(:,6:10), 'd'); % Data plotting of concentration of solute in feed solution
ylabel('Concentration of species(mg/L)');
xlabel('Time (hr)');
legend('Phosphates','Total Nitrogen', 'Potassium', 'Sodium', 'Chlorides', 'Data Phosphates','Data Total Nitrogen', 'Data Potassium', 'Data Sodium', 'Data Chlorides');
title('Concentration profile of species in draw solution');
hold off

% Plotting water flux vs time
figure(3);
plot(linspace(0, 8, 50), pt, 'r-', data_t, data_flux, 'bo');
ylabel('Water flux [L/m^2/hr]');
xlabel('Time (hr)');
legend('Prediction', 'Data');
title('Water flux profile');

% Plotting rejection versus flux
% Data on solute rejections with time
data_flux = [4.9 3.9 3.12 2.54 2.08]; % Water flux [L/m^2.hr]
dat_rej = [0.917 0.899 0.877 0.868; 0.841 0.801 0.739 0.612; 0.727 0.686 0.596 0.448; 0.674 0.662 0.566 0.510; 0.824 0.816 0.742 0.682] *
100; % Rejections [%]
figure(4);
x = linspace(min(data_flux(2:5)), max(data_flux(2:5)), 50);
cc = jet(5); % use different colours
s = {'o' 's' '^' 'v' 'd'}; % use different markers
for i = 1 : 5;
hold all;
p(i,:) = polyfit(data_flux(2:5), dat_rej(i,:), 1);
f = polyval(p(i,:), x);
plot(data_flux(2:5), dat_rej(i,:), s{i}, x, f, 'color', cc(i,:));
xlabel('Water flux [L/(m^2.s)]');
ylabel('Rejections [%]');
title('Rejection versus water flux');
hold off
end
legend('Phosphates','P Quad','Total Nitrogen','N Quad', 'Potassium','K Quad', 'Sodium','Na Quad', 'Chlorides','Cl Quad');

wf = [4.9 3.9 3.12 2.54 2.08]; % Water flux [L/m^2.hr]
data_t = [0 2 4 6 8]; % Time [hr]
wf = spline(data_t, data_flux, t); % Water flux at time t [L/m^2.hr]
a = [a1 a2 a3 a4 a5];
b = [b1 b2 b3 b4 b5];

k1 = (a(1) * wf + b(1))*10^-2;
k2 = (a(2) * wf + b(2))*10^-2;
k3 = (a(3) * wf + b(3))*10^-2;
k4 = (a(4) * wf + b(4))*10^-2;
k5 = (a(5) * wf + b(5))*10^-2;
k = [k1 k2 k3 k4 k5];

figure(5)
plot(wf,k);
legend('P lin','N lin','K lin','Na lin','Cl lin');

```

```

function min = Objective_fnc_FO (k)

global data_flux data_t pt init_mas m_data dat_con data_volfeed a1 a2 a3 a4 a5 b1 b2 b3 b4 b5

a1 = k(1);
a2 = k(2);
a3 = k(3);
a4 = k(4);
a5 = k(5);
b1 = k(6);
b2 = k(7);
b3 = k(8);
b4 = k(9);
b5 = k(10);

t = [0 2 4 6 8] ; % Time [hr]
options = odeset('RelTol',1e-8, 'AbsTol',1e-3); %Integration
[t m_pred] = ode45('Solutflux', t, init_mas) ;
c = zeros(size(m_pred,1),10) ;

for i = 1:size(m_pred,1)
    v_feed(i,:) = m_pred(i,11);
    v_draw(i,:) = 1 + (1-v_feed(i,:));
    mod_con_feed(i,:) = m_pred(i,1:5)/v_feed(i,:) ;
    mod_con_draw(i,:) = m_pred(i,6:10)/v_draw(i,:) ;
end

mod_con = [mod_con_feed mod_con_draw];
dif = (mod_con - dat_con)./mod_con;
dif = dif(:);
sqr_dif = transpose (dif) * dif ;
min = sqr_dif ;
end

```

```

function [ dmdt ] = Solutflux(t, m)

global data_flux data_t pt init_mas m_data dat_con data_volfeed a1 a2 a3 a4 a5 b1 b2 b3 b4 b5

% Interpolating flux
A = 140 * 10^-4 ; % Cross sectional area is 140 cm^2: [m^2]
data_flux = [4.9 3.9 3.12 2.54 2.08] ; % Water flux [L/m^2.hr]
data_t = [0 2 4 6 8] ; % Time [hr]
wf = spline (data_t, data_flux, t) ; % Water flux at time t [L/m^2.hr]
pt = spline (data_t, data_flux, linspace(0,8,50)) ; % For plotting

% Interpolating volume
data_volfeed = [1008.16 870.3 765.95 683.18 619.03] ; % Volume of feed solution with time [mL]
data_voldraw = [1000 1137.86 1242.21 1324.98 1389.13] ; % Volume of draw solution with time [mL]
v_feed = spline(data_t, data_volfeed, t) * 10^-3 ; % Volume of bulk feed solution at time t [L]
v_draw = spline(data_t, data_voldraw, t) * 10^-3 ; % Volume of bulk draw solution at time t [L]

% Concentration of species moving across the membrane
c_feed = [m(1)/m(11) m(2)/m(11) m(3)/m(11) m(4)/m(11) m(5)/m(11)] ; % Concentration of solute on the feed side at time t [mg/L]
a = [a1 a2 a3 a4 a5];
b = [b1 b2 b3 b4 b5];

k1 = 1-(a(1) * wf + b(1))*10^-2 ;
k2 = 1-(a(2) * wf + b(2))*10^-2 ;
k3 = 1-(a(3) * wf + b(3))*10^-2 ;
k4 = 1-(a(4) * wf + b(4))*10^-2 ;
k5 = 1-(a(5) * wf + b(5))*10^-2 ;

% Solute species on the feed solution side
dmdt = zeros(11, 1) ; % Species monitored are: Phosphorous, Nitrates, Potassium, Sodium, Ammonia, Bicarbonate, Calcium

dmdt(1) = -wf * c_feed(1) * k1 * A ; % Phosphates [mg/hr]

dmdt(2) = -wf * c_feed(2) * k2 * A ; % Total nitrogen [mg/hr]

dmdt(3) = -wf * c_feed(3) * k3 * A ; % Potassium [mg/hr]

dmdt(4) = -wf * c_feed(4) * k4 * A ; % Sodium [mg/hr]

dmdt(5) = -wf * c_feed(5) * k5 * A ; % Chlorides [mg/hr]

% Solute species on the draw solution side

dmdt(6) = -dmdt(1) ; % Phosphates [mg/hr]

dmdt(7) = -dmdt(2) ; % Total nitrogen [mg/hr]

dmdt(8) = -dmdt(3) ; % Potassium [mg/hr]

dmdt(9) = -dmdt(4) ; % Sodium [mg/hr]

dmdt(10) = -dmdt(5) ; % Chlorides [mg/hr]

% Integrating flux to get volume

dmdt(11) = - wf * A ; % volume change on feed side [L/hr]

end

```