FINAL REPORT

FORCED AERATION COMPOSTING OF SEWAGE SLUDGE FOR RURAL COMMUNITIES

by

**La Trobe and Associates
303 The Mews
Rosebank
Johannesburg
2196**

Report to the Water Research Commission on Project 341 entitled

***Forced aeration composting of sewage sludge
for rural communities***

WRC Report No. 341/1/94

ISBN. 1 86845 043 0

TABLE OF CONTENTS

PILOT STUDY

i.	<u>EXECUTIVE SUMMARY</u>	<u>PAGE</u>
1.	INTRODUCTION.	1
2.	HISTORY AND FUNDAMENTALS OF THE FORCED AERATION COMPOSTING PROCESS.	2
3.	SITE OF PILOT STUDIES AND FULL SCALE OPERATION.	3
4.	PILOT STUDY EQUIPMENT.	4
5.	SOLID WASTE MATERIALS USED IN COMPOSTING EXPERIMENT.	5 & 5
6.	EXPERIMENTAL PROCEDURES.	7 & 8
7.	RESULTS OF PILOT STUDY.	9 & 10
8.	DISCUSSION.	11 & 12
9.	COMMENTS.	13
10.	CONCLUSIONS.	14
11.	ANNEXURES.	16

EXECUTIVE SUMMARY

Any Community, no matter how rich or poor, has two fundamental waste streams - domestic refuse and its own body wastes.

This Report demonstrates that it is technically feasible and economically viable to stabilise large quantities of unsorted and non-pulverised domestic refuse with primary sewage, particularly night soil or activated sludge, by means of a process of forced aeration composting.

With this method the composting process is accelerated to a mere twenty one days, provided the internal temperatures of the windrows (static piles) are properly controlled and monitored, the end product can be used without fear of producing infection. All the weed seeds, pathogens and ascaris worm cysts would have been devitalised.

It is important to remember that even if all the compost produced in the process cannot be used or sold, the two obnoxious waste streams, namely domestic refuse and raw sewage and sludges, would have been effectively stabilised at a comparatively low cost, using a technique which is simple. The process is capable of providing job opportunities for those who have not had a high degree of formal education.

The end product has uses other than a soil conditioner. Large quantities can be used as a landfill cover or as a solid fuel.

The process is kind to our fragile and constantly battered environment. It is apt, viable and simple technology for our third world conditions.

FORCED AERATION CO-COMPOSTING OF NIGHT SOIL USING DOMESTIC REFUSE AS A BULKING AGENT - A PILOT STUDY

1. INTRODUCTION

Sewage and refuse represent the major sources of polluted wastes generated by communities. These wastes have undesirable characteristics necessitating further processing and transformation into end-products to render them environmentally acceptable. Such treatment, generally termed stabilisation (Figure 1), remains a major cost factor in waste management (Ross, 1990). Stated in positive terms,

"Waste stabilisation may be defined as a series of processes producing an end-product of such characteristics that its ultimate use will be acceptable in terms of both environmental impact and public health (adapted from Vesilind et al., 1986)"

While numerous waste treatment options exist, the choice of stabilisation method will ultimately be dictated by site-specific criteria. Since each type of sludge and refuse and processing facility has unique characteristics, no universally "correct" approach can be said to exist. The final decision may be governed by a multiple of variables, including political considerations.

The supply of adequate sanitation systems in many developing countries, including South Africa, has deteriorated over the past decade due to a combination of demographic, sociological and economic factors. This has resulted in an urgent need for the development of low cost effective and appropriate waste management technologies for the treatment and disposal of human wastes (Alexander and Toerien, 1985). This need is particularly felt, not only in sub-economic rural communities, but also in the overpopulated outskirts of urban areas (such as squatter camps) where people are settling in search of better work opportunities.

Sewage disposal in less-developed areas is generally by means of the bucket system as there is no infrastructure for water-borne sewerage. The night-soil arising from the buckets is conventionally disposed of in lagoons which have to be situated some distance from the community. The practice is generally accompanied by bad odours and fly breeding. In turn, refuse is often disposed of by uncontrolled landfilling which impacts adversely on the environment.

Forced aeration co-composting of night-soil with unpulverised refuse as bulking and filtering agent could be a suitable cost effective process for the integrated stabilisation, disinfection and resource recovery of these two polluting waste streams.

A contract research project was negotiated with the Water Research Commission during 1990 to generate design criteria for practical application of the process. The registered trade name for the composting of refuse and night soil is CORANS.

The prototype pilot study was carried out at Rini, Grahamstown. (See Restricted W.R.C. Contract Reports Nos: 1 & 2 dated June 90 and January 91). As far as could be ascertained at the time, the concept of using unsorted domestic refuse as a bulking agent to stabilise night soil in a forced aeration process was unique in the world. These two reports authored by Dr W R Rose and Dr B E La Trobe formed the basis of a paper which was accepted at the Annual International Conference of the World Pollution Control Federation. The paper was read by B E La Trobe at a conference in Toronto, Canada in October 1991. A further paper on the full scale version of the process established at Rini, Grahamstown, was accepted for the Federation September 92 Conference, held in New Orleans, Louisiana, U.S.A. The paper was read by B E La Trobe. Both papers are attached to this report as part of the Annexures. The Toronto Paper was published in the International "WATER ENVIRONMENT AND TECHNOLOGY JOURNAL" Sept 1992.

2. HISTORY AND FUNDAMENTALS OF THE FORCED AERATION COMPOSTING PROCESS

2.1 HISTORY OF THE PROCESS IN THE U.S.A.

The Biological Waste Management Laboratory at the United States Department of Agriculture in Beltsville, Maryland began research on composting (biothermal stabilisation) of sewage sludge during 1972 at the request of the Maryland Environment Service and the Blue Plains Wastewater Treatment Plant in Washington, D.C. This work resulted in 1973 in a natural-draft windrow method utilizing wood chips as a bulking agent. However, difficulties with malodours and low temperatures in the outer layers of the windrows prompted further research at Beltsville sponsored by the United States Environmental Protection Agency (USEPA). By the middle of 1978 this project had resulted in the development of a successful forced aeration process using static piles (Willson et al., 1980).

Since the inception of the process during 1978 more than 400 sewage sludge composting plants have been constructed in the U.S.A. Although most of these plants are highly mechanised, the flexibility of the process allows its application in labour-intensive non-mechanised form in under-developed areas where there is a need for more affordable sewage treatment processes.

2.2 APPLICATION OF THE PROCESS IN SOUTH AFRICA

The Water Research Commission requested the National Institute for Water Research (NIWR) of the CSIR to produce a design guide for the forced aeration composting of sewage sludge and wood chips, under local conditions. The contract agreement provided for laboratory and prototype studies which were undertaken at Bellville during the period 1980 - 1986 (Nell and Ross, 1987). The process is currently being applied on a full-scale basis at the Stellenbosch Sewage Works, Borchers Quarry Sewage Works (Parow) and the Northern Sewage Works (Johannesburg) for the treatment of mechanically dewatered sewage sludges.

2.3 FUNDAMENTALS OF THE FORCED AERATION COMPOSTING PROCESS

Composting is defined as the solid-state aerobic biological decomposition of organic materials under controlled conditions which allow the build-up of biologically generated heat resulting in a stabilised and disinfected end-product. Although composting can occur under a wide range of conditions, the process is much less reliable at the extremes of these conditions (USEPA, 1981).

Utilisation of natural draft ventilation and manual turning of the windrow instead of forced aeration of a static pile would be cheaper but not nearly as effective. For proper control certain chemical, physical, thermodynamic, kinetic and biological aspects must be considered. These aspects have been discussed in detail by Ross et al, (1986) and Nell and Ross (1987) and are summarised in Table 1.

3. SITE OF THE PILOT STUDIES AND THE FULL SCALE INSTALLATION

A decision was made to carry out the experiments at the Waste Treatment Plant of Rini, outside Grahamstown, as all the necessary infrastructure was available there, namely :-

3.1 CO-OPERATION OF THE RINI TOWN COUNCIL

The following facilities were kindly supplied:-

- a) Experimental site adjacent to the pond system treating night soil.
- b) Labour and material to construct a concrete slab on which to carry out the composting experiments.
- c) Provision of mains water and electricity.

4.

- d) Provision of domestic refuse and night soil.
- e) Provision of dried sludge as insulation layer.
- f) Labour to construct the compost pile.
- g) Sieving of the composted product.

3.2 Suitability for Project Leader who lives in Grahamstown.

3.3 Availability of chemical and microbiological monitoring facilities at Rhodes University, if required.

3.4 As the basic infra-structure was already in position at Rini, Grahamstown, after completion of the initial experiments, it made sense to carry out the full scale test operation on the same site.

4. EQUIPMENT REQUIRED FOR THE FORCED AERATION COMPOSTING PROCESS

PILOT STUDY

The facilities required to conduct the pilot study composting experiment at Rini are illustrated in figure 2 and discussed below.

4.1 CONCRETE SLAB

A concrete slab (7m x 7m) was constructed on which to carry out the experiments, as the soil in the area was very clayey. A slight gradient was provided towards a centre drainage channel for leachate collection in a sump. Excess leachate was pumped from the sump to the pond system.

4.2 RADIAL VANE FAN

M150 model; 0,75kw; 0,2-0,6 m³ per sec; 2900 rpm; 280 mm diameter cast aluminium impeller; Starter and transformation on inlet and outlet to 100 mm; sprayed with tectyle aerosol for corrosion control. Agent: Continental Fan Works (Pty) Ltd., 3 Parin Road, Parow, Industria, 7500, Tel: 021 931-8331 Cost: R1115.32 (1990 price).

4.3 AERATION MANIFOLD TUBING

8m of HX 100mm heliflex medium duty PVC flexible tubing; tubing was plugged at one end and slotted over a 2m length to allow air to be drawn equally into the pile over a wide area. 7 Kininghall Avenue, Epping Industrial, 7460, Tel: 021 54-7051. Cost: R174.38 (1990 price).

5.

4.4 TIME SWITCH

Slimline Series Type ST 202

Agent: Main Street Electrical (Pty) Ltd.,
25 Neptune Street, Paarden Eiland, 7405
Tel: 021 511-7826
Cost: R210.18 (1990 price).

4.5 WATER TRAP

200 l Drum with 100mm inlet and outlet to accommodate the tubing. The drum was provided with a valve to drain any leachate and condensate that accumulated in it. This water trap was made by the Rini Workshop.

4.6 BACHARACH FLYRITE OXYGEN ANALYSER

Agent: Holpro Analytics (Pty) Ltd.,
P O Box 252, Milnerton, 7435
Tel: 021 52-2100
Cost: R1325.96 (1990 price).

4.7 DIAL THERMOMETER (1.5M LONG STEM)

Agent: Control Instruments.,
Drill Avenue, Montague Gardens
Tel: 021 551-3510
Cost: R533.36 (1990 price).

4.8 SIEVE

Manually operated sieve with a 25mm diamond mesh. The sieve was made by the Rini Workshop.

5. SOLID WASTE MATERIALS USED IN COMPOSTING EXPERIMENT

5.1 DOMESTIC REFUSE FROM RINI

Refuse is a complex conglomerate of organic and inorganic materials. An analysis of Rini refuse was carried out on 20 December 1989. Typical refuse from a tip-truck was placed in a metre box. The contents of the box were sorted and the various components such as glass, plastic, paper, metal and other "organics" were weighed. The results are presented in Table 2 which indicates that there was sufficient organic material in the sample to provide energy for biological decomposition.

6.

The Free Air Space of solids for composting can be determined by the following "rule of thumb" method:-

$$\begin{aligned}\text{Free Air Space (refuse)} &= 1 - \text{Bulk Density} \\ &= 1 - 0,17 \\ &= 0,83\end{aligned}$$

The Free Air Space of the combined refuse and night soil mixture should be greater than 0,4 for effective aeration in the process. The above result indicates that unpulverised refuse can act as a bulking agent for the filtered solids in night soil.

The refuse used as a bulking and filtering agent for night soil solids in Run 1 was unpulverised, so as to utilise the porosity and structural strength created by substances such as metal cans, plastic containers, bottles, cardboard boxes, etc. Refuse is generally very dry (moisture content less than 15%) but this creates no problems as the night soil has a moisture content of some 95%. The ideal moisture content at the start of the process should be in the range 50 - 60%. Too much moisture, however, is unsatisfactory as it fills the voids.

Both refuse and night soil have sufficient available energy for heat generation with the result that the ratio of the two components used in composting is not so critical and need only be adjusted to provide the necessary porosity for the forced aeration of the static pile. The aeration rate can be increased to compensate for reduced porosity of the pile.

5.2 NIGHT SOIL

The chief components of night soil are body wastes such as faeces and urine together with paper and rags. Night soil in its raw state is putrescible and rapidly develops strong and offensive odours. The polluting material is mainly of an organic nature. Inorganic matter such as grit or sand should not be present in large quantities.

The night soil was delivered to the experimental site in a tanker and some 3m³ was evenly spread over the refuse in layers, by control of an outlet valve. The solids content of the night soil was some 5% and this was thickened by filtration of the liquor through the layers of the refuse. The free leachate drained from the pile and was collected and pumped away to a pond system.

Such non-mechanical thickening of night soil solids considerably reduces the capital and running cost of the CORANS process. In comparison, conventional forced aeration composting processes require mechanically dewatered sludge to be mixed with a more costly bulking agent.

5.3 DRIED STABILISED SLUDGE AS BASE AND INSULATION LAYER

Stabilised sludge had been removed from the adjacent pond system used for the treatment of the night soil. The sludge had dried out and was found suitable for use as a base layer and as an insulation layer over the pile.

Previously composted material is generally used for this purpose. It has sufficient porosity to allow air to be readily drawn through the pile while being sufficiently non-porous to retain heat and exclude rainwater. Heavy rainfall, however, may cause problems by washing away excessive amounts of insulation material and by deeper penetration of dampness into uncovered heaps.

6. EXPERIMENTAL PROCEDURES

The prototype-scale static piles were constructed as follows:-

- 6.1 An initial 20cm thick layer (4m x 4m) of dried sludge was laid on the concrete slab.
- 6.2 The aeration in slotted manifold tubing was laid on the sludge layer and connected to the water trap and aeration fan. The water trap had to be emptied from time to time during the course of the experiment as it collected leachate and condensate.
- 6.3 Branches with leaves were laid over the manifold tubing to prevent fines from blocking the slots.
- 6.4 Consecutive layers of refuse and night soil were added to a height of some 1.5m. The solids in the night soil were entrapped in the refuse while the leachate filtered through the pile and was collected in the drainage sump. The refuse was transported from an adjacent stockpile by wheelbarrow while the night soil was gravitated from a tanker. The sides of the static pile were sloped to an angle of about 50 degrees. The volume of the completed pile was some 10m³ (area of bottom of pile was 4m x 4m; area of top of pile was 2m x 2m; height of pile was 1.5m).

8.

- 6.5 The heterogeneous nature of the pile contents made it difficult to sample for analysis of porosity and moisture content. Instead, the ration of the two waste streams was adjusted based on past experience of constucting other static piles.
- 6.6 The pile was covered with a 10 cm layer of dried sludge (similar to the base layer) to provide heat insulation and odour control.
- 6.7 The Beltsville method of aeration where the aeration rate is controlled by the residual oxygen concentration in the pile (Nell and Ross 1987). In practice, redial oxygen must be kept between 5% and 15% which requires aeration rates between 3-4 m³. t-1. h-1. Over aeration results in temperature losses (cooling) while under-aeration causes anaerobic conditions to occur.
- 6.8 Aeration by suction of air through the pile, instead of blowing, allowed the oxygen concentration in the exhaust gas to be measured and this practice is recommended. Suction was applied by means of the fan which was controlled by a time switch. The time switch settings of the fan during Run 1 are recorded in Table 4. After three days, the fan was operated for only 5 minutes in the hour with the result that the electrical running costs are low.
- 6.9 Originally eight galvanised pipes (2m long and 2cm diameter) were driven into the pile at different levels around the perimeter. So as to serve as temperature and residual oxygen monitoring points. A rubber stopper isolated the inside of these pipes from the outside.
- With experience it was proved that these galvanised tubes were an unecessary expense, the temperature probe was placed directly into the static pile at specifically marked points.
- 6.10 The construction of the pile was completed in one day with the assistance of four labourers. Thereafter the aeration was automatically controlled by the fan and time switch. Monitoring for temperature was the most important parameter to assess the success of the experiment.
- 6.11 After 60 days composting the pile was manually screened with a sieve of 25mm diamond mesh size.

A process flow diagram of the unit operations for the composting of night soil and refuse is illustrated in Figure 3. The process comprises thickening of night soil by filtration through refuse, aeration in a static pile, maturation and screening. The liquid fraction of the waste stream (originating from the washing of buckets and the leachate drained from the composting pile) is ideally treated in an adjacent pond system.

7. RESULTS OF PILOT STUDY

7.1 TEMPERATURE PROPHILE

The temperatures reached at the eight monitoring points in the pile are presented in Table 3. A graphical record of the temperatures of monitoring points 2 and 8 together with the daytime ambient temperature is plotted in Figure 4. The data indicates that the prototype scale Run 1 gave good results in terms of the maximum temperatures reach - 68 degrees centigrade - and the distribution of the heat within the pile, which adequately reflects full-scale thermodynamic conditions. This result agrees with those obtained by Nell and Ross, (1987) where temperatures of between 60 and 71 degrees centigrade were usually obtained with mixtures of dewatered primary sewage sludge and wood chips.

Figure 4 indicates a rapid increase in temperature from 30 to 68 degrees centigrade in seven days after commissioning the pile on the 1st February 1990. The significant difference between the temperatures inside and outside the pile illustrates the biothermal activity of the micro-organisms and the energy potential of the refuse and night soil mixture. The temperature prophile over time is a convenient method to assess whether the composting and maturation processes are completed.

7.2 DISINFECTION EFFICIENCY

Composting has the advantage of both stabilising and disinfecting the solid wastes. Maintenance of higher temperatures for longer periods of time results in improvement in volatile matter reduction and disinfection. The USEPA (1981) recommends that the temperature within the pile should exceed 55 degrees centigrade for at least 3 days in order to ensure inactivation of all pathogens. This was the case in Run 1 for monitoring point No. 8. Thereafter, temperatures of 60 and 56 degrees centigrade were recorded for monitoring points 8 and 2 respectively after 21 days operation.

Previous research (Nell and Ross, 1987) has shown that disinfection was adequate during the composting (aeration) and maturation (non-aeration) period. No pathogenic bacteria, viruses or viable *Ascaris* ova survived longer than 40 days in the pile. Regrowth and re-infection can however occur (Willson, 1986). This is not unique to sludge composting but occurs in all bulky bio-degradable organic materials stored in the open, close to a possible source of infection.

- 7.3 Table 4 records the time switch settings which activated the aeration fan during Run 1. Aeration was maintained at a relatively higher rate (60 minutes ON: 60 minutes OFF) during temperature ascent and at a relatively lower rate (20 minutes ON: 40 minutes OFF) once a turning point in the temperature curve was observed after 9 days operation (Figure 4). After 26 days operation, the aeration rate was 5 minutes ON: 60 minutes OFF which was equivalent to 3m³/ton/hour.

The following assumptions were made for calculation of the aeration rate of the pile during Run 1:

Volume of pile	=	10m ³ (approximate)
Density of pile	=	1 ton/m ³ (approximate)
Mass of pile (wet)	=	10 ton
Fan rating	=	24 m ³ /min (disconnected from pile)
Fan rating	=	6 m ³ /min (connected to pile)
Time switch setting	=	5 min/hour
Aeration rate	=	3 m ³ /ton/3 hour (day 26 to day 48)

The oxygen concentrations in the exhaust gas extracted from pile during Run 1 are presented in Table 5. The Bacharach oxygen analyser generally recorded concentrations similar to that in air during the experimental period indicating that either the rate of aeration was too high or the monitoring procedure was faulty. This aspect will be addressed in future experiments.

Large variations in ambient temperatures, especially during winter nights, would adversely affect the temperatures in the pile by drawing in excessive amounts of cold air. Aeration periods during cold weather should therefore be shortened.

7.4 FINAL COMPOSTED PRODUCT

The compost pile (excluding the base and insulation layers) was sieved after the experiment of 60 days and the sieved fraction was weighed. The yeild of final product was arbitrary calculated as follows:-

Initial mass of wet solids	=	10 ton (approx)
Final mass of dry sieved compost	=	2.7 ton
Yield of dry sieved compost	=	27%

The composted mixture of refuse and night soil was easily sieved and had a very good humus-like appearance. The end product was dry, had a loose friable texture, was black in colour and had a pleasant smell. It was nothing like the original products which were putrescible and had high offensive malodours. Experiments will be undertaken to determine the agricultural utilisation of the compost.

8. DISCUSSION

8.1 DISADVANTAGES OF THE CORANS PROCESS

The filtering of night soil through refuse to entrap the solids is naturally a more "messy" operation than mechanical dewatering. Problems with odour generation and fly-breeding can be overcome by adding the final insulation layer as quickly as possible. Lime can also be used to suppress malodours while the pile is being constructed. During the first few days of operation any obnoxious odours in the exhaust gas from the fan can be eliminated by passing the gas through a matured compost filter pile.

The leachate draining from the static during construction is channelled to a pond system. Such ponds will operate better as the organic load to be treated is considerably reduced by the composting of the solid fraction of the night soil.

8.2 ADVANTAGES OF THE CORANS PROCESS

The advantages and features of the forced aeration process for the composting of refuse and night soil can be summarised as follows:-

- * It is an appropriate waste management technology which requires simple equipment and unskilled labour and is suitable for application in less-developed areas.
- * It is an ecologically acceptable resource recovery method which reduces public health hazard and impacts positively on the environment.
- * The integrated composting of refuse and night soil in association with a pond system comprehensively treats and manages the two major sources of polluted wastes generated by less-developed or rural communities.

- * Recycling of nutrients by production of a humis-like soil conditioner with a relatively high nitrogen content (1.5 to 3.0%).
- * Production of a dry compost that is easy to handle.
- * Self-generated high temperatures (60-70 degrees centigrade) results in disinfection of pathogens and production of a hygienically safe end-product.
- * Relative insensitivity of the microbiological process to changes in substrate and growth conditions allows for wide differences in the input materials (refuse and night soil).
- * Use of refuse as a bulking agent has the advantage that it provides more energy (heat generation capability) and nutrients to the overall composting process than other more expensive bulking agents such as wood chips which are not as biodegradable as refuse.
- * The capital and operating costs for the co-composting of refuse and night soil are significantly lower than for conventional forced aeration composting processes because no mechanical dewatering equipment, mixing equipment nor bulking agent needs to be purchased.
- * Flexibility of the process allows application in highly mechanised (low labour) or in unmechanised (labour intensive) form. In general, site-specific criteria, availability of capital and the cost of labour will govern the degree of mechanisation that can be incorporated (Ross et al., 1986).
- * The combined treatment of these two polluted waste streams close to the source of generation thereof, enables the waste transportation costs to be kept to a minimum.
- * Costs can be reduced considerably in less-developed areas by choosing a site requiring a minimum of earth-work, mixing and sieving by spade and using less costly pad surfaces.
- * There is a potential income from the sale of the compost which would offset the costs. There will also be a financial benefit derived from the sale of scrap metal, plastic and glass which will be sieved from the mixture on completion of the composting process.

- * There are no intrinsic restrictions on the size of the plant. Use of the extended pile method reduces the land requirements (surface area) of the composting pad.

9. COMMENTS

9.1 TEMPERATURE PROPHILES

Uniformity of temperatures throughout the static piles (Table 3) were not entirely satisfactory. This could be explained as follows:-

- a) The use of a 100mm heliflex medium duty flexible tube with small slits for aeration was not satisfactory for a number of reasons:-
 - i The aeration holes were too small and the pipe diameter was inadequate.
 - ii Pressure of the weight of the composting material would have decreased the pipe diameter.
 - iii Placing the pipe directly on the slab over the drainage canal, instead of elevating it, meant that the aeration pipe was continually filling with drainage water cutting down on potential pipe aeration space.

Aeration pipe design has changed dramatically with experience obtained in composting studies conducted for the meat and fresh vegetable industries and at tanneries. These more recent aeration techniques result in a more uniform temperature profile throughout the windrow.

- 9.2 Concrete slabs on which to build the windrows are not always necessary. Provided site area geology allows proper drainage this expense can be avoided. However, beware of operating on an area with a clay base.
- 9.3 Material screening must be performed in a rotational or vibratory screen. The mesh size of 25 mm should be reduced to a 10 or 12 mm diameter.
- 9.4 The yields of compost obtained in the first run, it is now realised, were exceedingly low. Admittedly a great deal depends on the quality of the domestic refuse used as the bulking agent, however yields of at least 60% are not impossible.
- 9.5 Recorded oxygen levels in the exhaust gas as demonstrated with the Backrach instrument did not prove to be satisfactory.

10. CONCLUSION

The results of the Pilot Study have indicated that the biothermal stabilisation (composting) of refuse and night soil by means of forced-aeration is technologically and economically feasible. The combination of composting for solid wastes and ponds for liquid wastes would be particularly appropriate as a waste management system for less developed communities where a non-sophisticated, low cost and labour intensive technology is required.

A N N E X U R E S

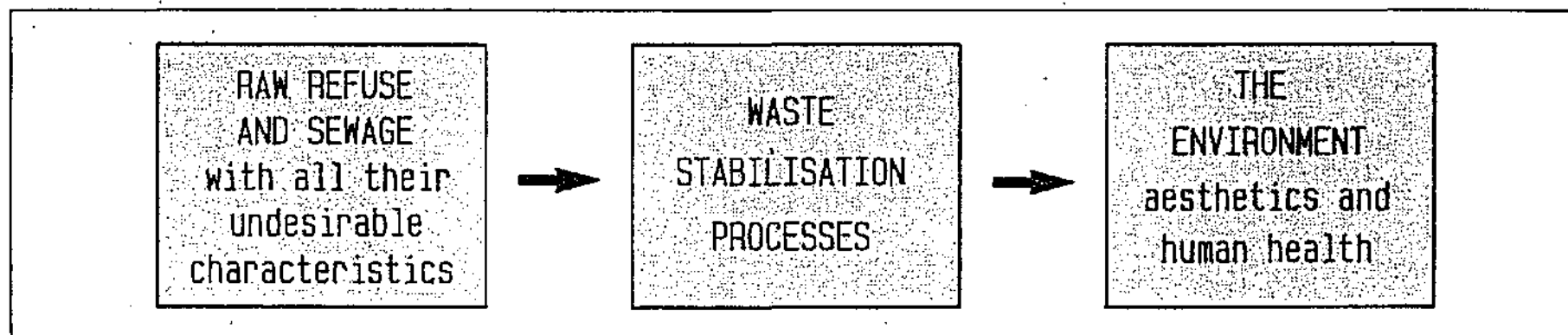

FIGURE 1 : HOLISTIC CHARACTERISATION OF COMMUNITY WASTE MANAGEMENT

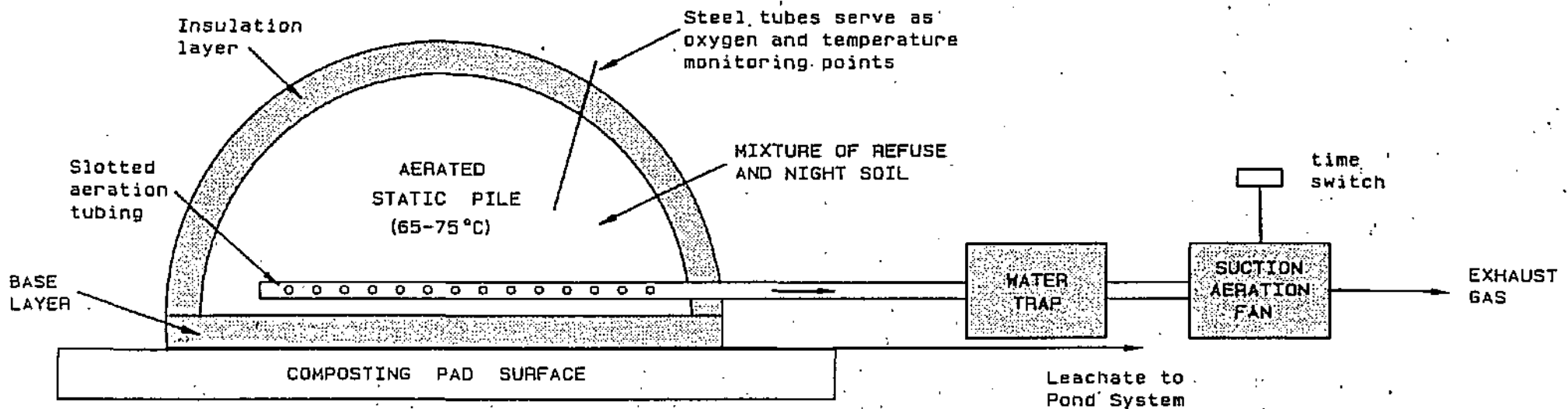

FIGURE 2 : FACILITIES REQUIRED FOR FORCED AERATION COMPOSTING OF REFUSE AND NIGHT SOIL

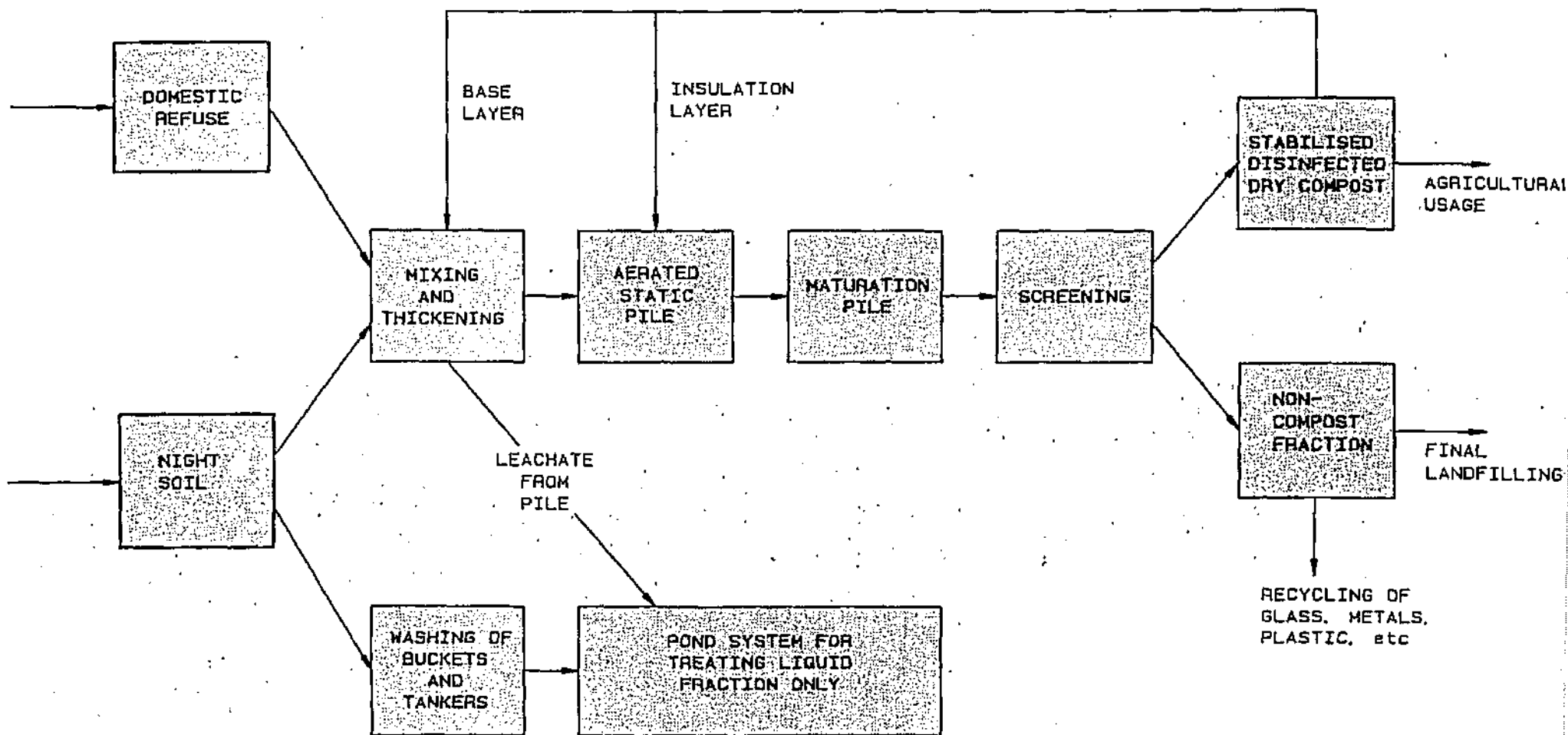

FIGURE 3: UNIT OPERATIONS OF THE FORCED AERATION STATIC PILE PROCESS FOR THE COMPOSTING OF REFUSE AND NIGHT SOIL (CORANS PROCESS)

FORCED-AERATION COMPOSTING OF DOMESTIC REFUSE AND NIGHT SOIL

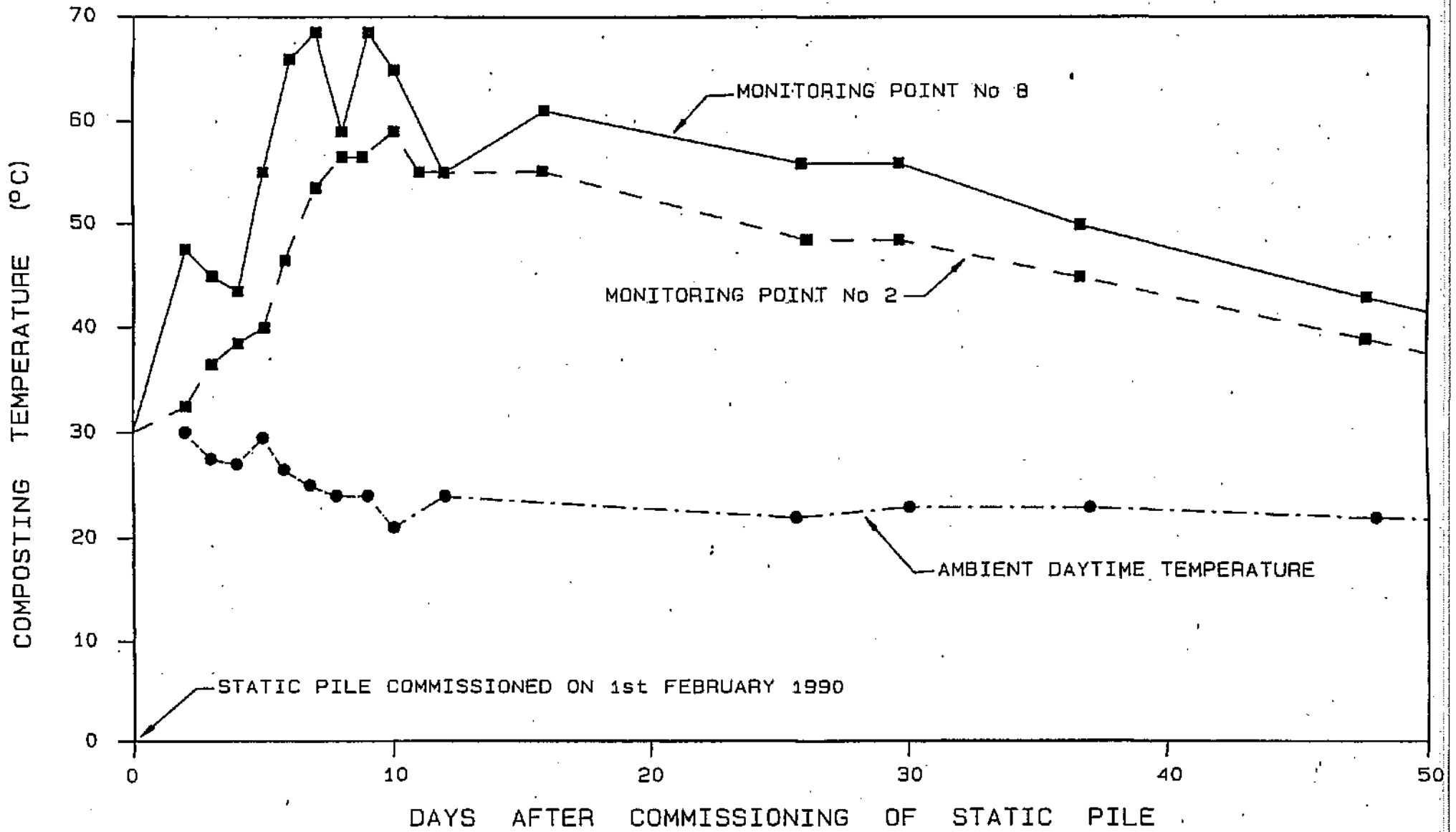

FIGURE 4 : COMPOSTING TEMPERATURE DURING RUN 1
CARRIED OUT AT RINI, GRAHAMSTOWN

TABLE 1: CERTAIN PHYSICAL CRITERIA FOR FORCED AERATION
COMPOSTING OF SOLID WASTES

PARAMETERS	VALUE
Carbon: nitrogen ratio of pile	30 : 1 to 40 : 1
Optimum pH range of pile	6,5 to 7,5
Optimum particle size of solids	5 to 15mm
Degradability coefficient (sludge)	kr = 0.7
Degradability coefficient (wood chips)	kr = 0.25
Degradability coefficient (final product)	kr = 0.18
W - ratio (thermodynamic balance of solids to be composted)	less than 10g water per 1 gram of degradable organic matter
Density of refuse	500 kg/m ³
Density of sludge	800 - 1050 kg/m ³
Aeration rates	3 - 4 m ³ /t-1.h-1.
Free air space	greater than 0.4
Moisture content of pile (start)	50 - 60%
Moisture content of pile (end)	less than 40%
Temperature within pile	should exceed 65 degrees Centigrade for at least 5 days
Residual oxygen concentration in exhaust gas from pile	5 - 15%
Composting period (aeration)	21 days
Maturation period (non-aeration)	21 days
Land area requirements	0.4 - 2.0 ha for population equivalents of 28000 - 350 000

TABLE 2 : COMPOSITION OF 1 m³ DOMESTIC REFUSE AT RINI TOWNSHIP
(SAMPLED ON 20 DECEMBER 1989)

CONSTITUENTS	MASS	%
Glass	15	8.8
Plastic	37	21.6
Paper	18	10.5
Metal	7	4.0
Other "Organics"	94	55.1
Total	171	100.0

Note : Bulk Density of refuse - $\frac{\text{mass}}{\text{volume}} = \frac{0.171 \text{ ton}}{1 \text{ m}^3} = 0.171 \text{ ton/m}^3$

TABLE 3 : TEMPERATURE OF VARIOUS MONITORING POINTS OF THE STATIC PILE DURING PROTOTYPE-SCALE FORCED AERATION COMPOSTING OF REFUSE AND NIGHTSOIL (RUN NO. 1)

DATE 1990	DAYS AFTER START-UP	TEMPERATURE OF MONITORING POINTS (C) AT DIFFERENT LEVELS AROUND THE PERIMETRE OF THE PILE								AMBIENT DAYTIME TEMPERATURE (C)	
		1	2	3	4	5	6	7	8		
02	February	2	33	32	33	33	33	34	34	47	30
03	February	3	35	36	36	35	34	38	41	45	28
04	February	4	38	38	38	35	35	42	44	44	27
05	February	5	35	40	42	40	33	47	50	61	27
06	February	6	48	46	45	42	36	52	52	66	26
07	February	7	54	53	55	46	46	56	56	68	25
08	February	8	56	56	46	48	55	56	58	62	24
09	February	9	57	56	55	49	47	57	52	68	24
10	February	10	54	58	55	50	48	58	56	65	21
12	February	12	50	55	52	48	46	55	55	55	24
13	February	13	48	53	52	47	47	56	54	60	23
14	February	14	50	54	53	48	49	56	53	60	24
15	February	15	48	53	53	47	48	57	52	61	24
16	February	16	48	55	52	48	48	57	54	61	23
19	February	19	53	56	51	46	48	57	55	62	24
20	February	20	52	56	50	46	47	56	52	60	26
22	February	22	48	55	48	47	47	55	50	60	19
23	February	23	47	56	49	47	47	56	48	59	20
26	February	26	48	48	44	44	44	53	45	56	23
27	February	27	42	52	46	45	45	51	46	61	26
28	February	28	42	52	46	45	45	51	44	57	24
01	March	29	41	50	46	45	44	49	41	54	24
02	March	30	43	48	45	44	44	48	44	56	24
05	March	33	40	45	43	42	42	46	43	52	23
06	March	34	40	46	44	42	42	47	42	50	21
07	March	35	39	45	44	42	43	47	44	53	20
08	March	36	39	45	43	42	42	45	43	50	22
09	March	37	39	45	43	42	42	45	43	50	24
12	March	40	37	42	39	40	39	44	40	45	22
13	March	41	37	42	40	39	39	45	40	45	24
20	March	48	34	39	38	37	38	41	32	43	22
23	March	51	35	39	38	36	37	39	35	41	23
26	March	54	34	39	37	35	36	40	37	40	22
27	March	55	33	39	36	35	35	39	36	41	21
28	March	56	34	39	37	36	36	39	35	40	20
29	March	57	34	39	36	34	35	39	34	38	20

TABLE 4 : TIME SWITCH SETTINGS FOR AERATION FAN AND APPROXIMATE AERATION RATE OF STATIC PILE FOR RUN NO. 1

DATE	DAYS AFTER START-UP	TIME SWITCH SETTING		AERATION RATE OF STATIC PILE (m ³ .t-1.h-1.)
		MINUTES ON	MINUTES OFF	
01 February	1	240	7	144
06 February	6	60	60	36
09 February	9	20	40	12
26 February	26	5	60	3
20 March	48	2,5	60	1,5

TABLE 5 : MEASURED OXYGEN CONCENTRATIONS IN EXHAUST GAS FROM STATIC PILE DURING RUN NO. 1

DATE 1990	DAYS AFTER START-UP	OXYGEN CONCENTRATIONS OF MONITORING POINTS AT DIFFERENT LEVELS AROUND THE PERIMETER OF THE POLE (%)								
		1	2	3	4	5	6	7	8	
02 February	2	20	20	20	20	20	20	20	20	20
09 February	9	20	20	20	20	20	20	20	20	20
19 February	19	20	20	20	20	20	20	20	20	20
05 March	33	19	18	17	16	16	16	16	16	19
09 March	37	19	17	17	17	16	19	14	17	

NOTE : Bacharach Fyrite oxygen analyser was standardised in air at a known temperature.

TABLE OF CONTENTS

FULL SCALE STUDY

	PAGE
1. INTRODUCTION	1
2. FUNDAMENTALS OF FORCED AERATION COMPOSTING	1
3. SITE OF FULL SCALE PROJECT	1
4. FUNDING OF FULL SCALE PROJECT	2
5. PRESENT SYSTEM OF RINI SEWAGE COLLECTION	2
6. RINI EVAPORATION POND SYSTEM	3
7. THE PRESENT SYSTEM	3
8. R & D TO ENSURE PLANT SUITABILITY PRIOR TO EQUIPMENT PURCHASE.	4
9. FULL SCALE OPERATIONAL PROCEDURES	5
10. EQUIPMENT REQUIRED FOR FULL SCALE OPERATION	7
11. WINDROW MONITORING	9
12. PROJECT EVALUATION	10
13. CONCLUSIONS	15
14. REFERENCES	16
15. ANNEXURES	18

FORCED AERATION CO-COMPOSTING OF NIGHT SOIL AND DOMESTIC REFUSE
AT RINI, GRAHAMSTOWN. THE FULL SCALE OPERATION - APRIL 1993

1. INTRODUCTION

The pilot study conducted at the Rini site during 1990 proved successful to the point that it was felt that a gradual introduction to a full scale operation of treating domestic refuse and night soil could be handled with confidence. This plant could be used as a demonstration site to prove to other local authorities and international institutions, searching for low cost sewage solutions, that the process was viable.

Any community, no matter how rich or poor, has two major waste streams, domestic refuse and body wastes. The object of the project is to demonstrate the feasibility of stabilising large quantities of these two important waste streams into an end product which does not have undesirable characteristics.

The supply of adequate sanitation systems in developing countries have deteriorated for many reasons, and as a result there is an urgent need for low cost, appropriate sewage treatment technology. The need is particularly required in overpopulated outskirts urban areas where people are settling in search for work.

2. FUNDAMENTALS OF THE FORCED AERATION COMPOSTING PROCESS

The fundamentals of the forced aeration composting process have been fully discussed in the pilot study section, so will not be repeated here.

3. SITE OF THE FULL SCALE PROJECT: RINI, GRAHAMSTOWN

The reasons for choosing Grahamstown have been previously stated. In addition, Rini was been threatened by a Supreme Court order to close this sewage treatment facility, because of obnoxious odours reaching the nearby Escom Installation. Surrounding farmers were also complaining bitterly about the offensive odours.

4. FUNDING OF THE FULL SCALE PROJECT

The delay in starting up the full scale operation was purely financial.

The budget required for the initial project was in the vicinity of R170 000 00. This figure eventually escalated to about R200 000 00.

VARIOUS INSTITUTIONS WERE APPROACHED TO ASSIST WITH FUNDING

- a) Rini Town Council. The reply was negative.
- b) Cape Provincial Administration, who is responsible for water treatment in the area. The undersigned visited the C.P.A. Officials in Cape Town. A copy of my report to the Rini Council is enclosed with the Annexures. The report is dated 7 March 1991. The final reply was negative.
- c) The Algoa Regional Service Council. This application included with the Annexures, is dated 26 August 1991. Many hours of negotiating precede this formal application. However, the application was eventually approved by the Algoa Regional Service Council under its small projects budget section and the funds became available about the beginning of 1992.

At this stage it must be stressed that without the understanding of the Water Research Commission Officials - Mr P Odendaal, the Chief Executive and Dr O Hart, together with the Director, Engineering Services, Mr John Kemp and the Chairman - Mr James Kleynhans - of the Algoa Regional Services Council, this project would never have seen the light of day.

5. THE PRESENT SYSTEM OF RAW SEWAGE COLLECTION AND TREATMENT

- 5.1 Fingo Village and parts of the area known as Tanttjie are served by waterborne sewage which drains into the Grahamstown City water treatment plant.

Most of the town is serviced by a nightsoil bucket system. The remainder, mainly the area known as Extension 5, which contains the more recent and expensive housing development, has a system of conservancy tanks which are drained periodically.

- 5.2 Using a conservancy tank system for the Rini area, displayed an unfortunate disregard for the local conditions and geology.

Rini is built on a solid slab of clay which is subject to ground movement. Many of these tanks cracked, with the resultant leakage of the contents.

Neighbours share conservancy tanks with expected arguments, as to who causes the tank to fill quicker, etc. When the tanks are evacuated the smell is horrendous.

- 5.3 There is an added complication. The contents of conservancy tanks is either discharged into a sewer which drains into the Grahamstown works, where it complicates sewage treatment in an already overloaded works, or is discharged into Rini's own evaporation pond system. This pond system is also in an overloaded and overstressed state. The system attempts to purify the night soil by forced aerating it. When the contents of the conservancy tanks is discharged into the ponds it is already in an anaerobic phase, which defeats the attempt to purify the sewage by aerobic techniques.

6. THE RINI EVAPORATION POND SYSTEM

- 6.1 Nightsoil is delivered by various capacity trucks. The total volume delivered to the works is probably between 30 to 35 cubic metres per day. The system was designed to treat between one third to half of that volume.

The contents of each truck is allowed to flow by gravity, in the open air, through a set of grisly filter bars and hence into a large diameter pipe (250mm), which runs to a gate valve which controls the flow into either of the first two ponds.

- 6.2 All ponds, six in all, have a dimension of 60 metres by 30 metres and about 2,5 metres deep. The ponds nearest the gate valves are concrete lined, the rest are merely excavations in the ground. The two concrete ponds are served with island electrical aerators.

7. THE PRESENT SYSTEM - AUGUST 1991

- 7.1 Only the two concrete ponds are in operation and are totally overloaded. The remaining four ponds are dry and contain a large proportion of solid sludge, which should never have been allowed to happen.

One of the concrete ponds is so overloaded that it is covered with a thick crust, so thick it was possible to walk on it, so this pond which is supposed to be aerobic is totally anaerobic. Recently an attempt has been made to place new aerators in this pond.

- 7.2 In my opinion this was a waste of electricity used., as the aerators would not be able to reverse the anaerobic condition, and the aerators would breakdown because of the adverse working conditions. From my observation this breakdown has already occurred, as predicted.
- 7.3 Some months ago the contents of the second concrete pond was pumped with a hired pump onto an adjacent vacant land, in an attempt to alleviate the situation. In fact, it merely moved the problem from one place to another. It was extremely fortunate that we did not have heavy rain at the time, as the stormwater drainage of this area ultimately leads down into the Belmont Valley. The farmers in this valley are mainly vegetable farmers who irrigate from the river. Infected material reaching this river could have caused untold microbial havoc.

8. RESEARCH AND DEVELOPMENT TO ENSURE PLANT SUITABILITY PRIOR TO PURCHASE

Because of the physical characteristics of the night soil there was concern that the sludge pumped to the cone settling tanks would not thicken before spraying onto the windrows. The report is tabled in the annexure.

In essence the test showed a large number of solids floated to the surface, but after overnight separation trials, there was definite solid settlement to the bottom of the vessel. It was felt that the solid floatables would be eliminated by the emascerator pump situated in the screening sump.

- 8.1 The L.I.R.I. Technologies report on this subject is tabled in the annexures.

Further tests conducted by L.I.R.I. laboratories demonstrated that the sludge in the settling cones after emasceration and an overnight settling thickened to a total solids content of about 4.6% solids.

Research on the percentages of basic ingredients in the domestic refuse was reported in the pilot study report.

9. FULL SCALE OPERATIONAL PROCEDURES

- 9.1 Nightsoil is delivered to the site and discharged into the first sump by gravity. A sluice gate has been installed to control the flow to the screen, where the water jets ensure maximum delivery to the emascerator pump in the sump below the screen.

The resultant sludge is pumped to the settling cone tanks at a rate of 12 cubic metres per hour. The two settling tanks have a combined capacity of 32 cubic metres which is about the volume of nightsoil arriving at the sewage works each day.

9.2 WINDROW BUILDING

Domestic refuse is delivered to the site and deposited over the prepared aeration pipes; the windrow base is kept to the designed dimensions of 20 metres long and 3 metres wide. The windrow height is kept to 2 metres. The windrow sides are sloped to about 50%. As each trailer load of refuse is levelled on the windrow bed, plastic bags of refuse are slashed open and large inert material is removed.

The refuse layer is liberally sprayed with sludge from the settling cones at the rate of 200 litres per minute. This is then covered with a further layer of refuse. Each windrow built to the dimensions previously described will have received a sludge coverage of about 16 000 litres or the total capacity of one settling tank.

The domestic refuse acts as a filter retaining the sludge solid content. The leachate liquid draining from the windrow collects in a cemented channel which returns this liquid to the oxidation pond for aeration and evaporation.

By removal of the solids prior to entry into the oxidation ponds, the stress on the pond is reduced and the rate of evaporation becomes more efficient.

- 9.3 Water from the evaporation ponds is used to irrigate the 120 pepper trees planted around the periphery of the site. The nutrients benefit the growth of the trees and pure water is vented to the atmosphere by natural transpiration.

- 9.4 Completed windrows are covered with a 25 mm layer of old matured sludge cake or available compost to act as an insulation, weather protection and to reduce fly infestation.

Each windrow contains about 100 cubic meters of material but tends to diminish in volume during the course of the composting process due to compaction and subsidence.

On completion of the windrow the aeration pipe is connected to the fan blower. Air is pulled continually through the pile for the first 24 hours, thereafter the fan is controlled by a time switch set to operate on a 20 minute cycle. Four minutes on and 16 off.

Rapidly the biological heat level within the windrow rises to levels where the weed seeds are devitalised (45 degrees centigrade). When the temperature rises to 55 degrees centigrade and is held at this level for a period of three days, all pathogens and worm cysts are destroyed. Usually temperature levels rise to levels in excess of 65 degrees centigrade. Windrow temperatures are monitored on a daily basis. See Annexures for temperature tables.

After twenty one days the aeration of the windrow is stopped and the contents are removed to a maturation pile where there is usually a second rise of temperature due to the aeration created by windrow removal. After a cooling and drying period of a further fourteen days the material is ready for screening.

9.5 AERATION TECHNIQUES

Aeration techniques during full scale operation varied with experience. Initially 100 mm class 9 blue plastic piping was used. Each windrow of 20 metres long had a 18 metre aeration pipe in the middle of the windrow base with random holes drilled over the mid 16 metres of the pipe. The remote end of the pipe was closed with a bung. Later windrows were aerated with graduated holes drilled into the pipes to give a more uniform pattern of aeration.

The high cost of piping and damage to these pipes during windrow clearing necessitated a search for acceptable alternatives. Two other methods were tested; plastic crates and remodelled wooden pallets.

- 9.6 The matured windrow material is stabilised and ready for screening; it is no longer toxic or obnoxious. The material is worked through an electrically operated rotary screen to a particle size of 12 mm.

The screen is inclined. The composted material passes through the screen, while all the plastic, tins, glass and other inert material passes out the end of the screen and is stored.

Glass is recovered for recycling. The plastic is baled for sale and other inert material is taken to the landfill site. The yield of organic compost varies between 50 to 60% per windrow.

9.7 POTENTIAL USAGE AS A PLANT GROWING MEDIUM

This pathogenic free screened medium is available for use to encourage plant growth by the Town's Park and Garden Dept., distribution onto playing fields or sold to neighbouring farmers. Analysis for trace elements demonstrates that the product is safe for use on domestic vegetable gardens. See Annexure of Chemical & Microbiological Analysis.

10. EQUIPMENT REQUIRED FOR THE FULL SCALE OPERATION

- 10.1 The nightsoil from the delivery tankers is allowed to flow into a sump by gravity, where it is filtered of large objects (bricks, stones etc.) prior to flowing into a 250 mm pipe which is connected to the rotary screen equipped with a canopy. The screened material falls into another sump below the screen where the diluted nightsoil is emulsified and pumped in below ground piping (110 mm class 9 pvc) to overhead settling cone tanks. By means of flexible piping (50 mm dia) the thickened nightsoil is spray distributed over the domestic refuse in the built up windrows. Each layer of domestic refuse is covered with chipped garden refuse prior to the application of the nightsoil spray. The windrows are built to a height of two metres.

Leachate flowing from the windrows is returned to the screen sump by means of concrete channel.

10.2 ROTARY SCREEN

A rotary screen fitted with high pressure water jet sprayers at a pressure of 4 bars. This breaks down the solids to pass through the screen apertures of 15 mm.

The solids that defy breakdown are continuously passed out of the screen drum by means of a helical screw into a bin.
 Cost of the Screen : R30 206 00 vat included, June 92
 Supplier : Basic Mineral Engineering,
 Box 41435, TVL, 2024

10.3 SUMP

The sump is fitted with a submersible pump, which has a cutting mechanism to chop up solids into a fine state. The blended solids are then pumped to two sedimentation settling cones which are connected in parallel. The pump delivers the effluent to the cone tanks at a rate of 10 - 12 m³ per hour.

Cost of Sump : R10 000 00
 Born by Rini Council
 Emascerator Pump : R12 275 00, June 92
 Mono Pumps, Box 8136, TVL, 1613

10.4 SETTLING CONES

The capacity of these two vessels is 16.000 litres each (16m³). The days discharge of nightsoil is allowed to settle and thicken overnight. The thickened liquid is drawn from the base of the cone where there is a shut off valve. The sludge is conveyed to the windrows areas for spraying onto the garbage by means of a flexible hose (50 mm dia). The supernatant overflow liquid from the settling cones discharges by gravitation via pipes to the nearby oxidation ponds.

Cost of Tanks : R48 730 00
 Supplier : Fam Trading, Box 178, TVL, 2021

10.5 WINDROW BASES

The windrow bases in the pilot study were constructed concrete slabs. To reduce costs in the full scale plant the ground was merely graded with a slight slope. Windrow dimensions - 20 metres long X 3 metres wide and 2 metres high.

10.6 THE AERATION MANIFOLD PIPING

This consists of three lengths of 110 mm piping each 6 metres long. The first two metres of the pipe was not perforated. The remainder of the pipe lengths were perforated with holes of varying diameter to ensure a uniform air suction along the length of the windrow. The remote pipe extremity was closed with a bung. All the perforations were bound with a layer of shade cloth to prevent solid access into the aeration pipe. These windrows are interconnected to one fan blower. Presently six windrows are operated by two fan blowers.
 Cost of Piping : R4000 00 for 3 windrows
 Alternative aeration systems have been described.

10.7 RADIAL FAN/BLOWER

A Radial Vane Fan Blower capable of an extraction rate of about 150 M³/hr at 2900 R.P.M.

Cost : R4000 00 (June 92)

10.8 A TIME SWITCH to regulate the flow of air through the windrows.

Cost : R500 00 each (June 92)

10.9 A 200 litre WATER TRAP with 110 mm inlet and outlet. The trap was provided with a drain valve to release accumulated leachate and condensate.

10.10 A DIGITAL THERMOMETER with an attached recording stem.

Cost : R500 00 (June 92)

10.11 ROTARY ELECTRICITY OPERATED SCREEN

Cost : R10 000 00 (June 92)

11. WINDROW MONITORING

During the course of this study the following observations were carried out:-

1. Temperature on a daily basis
2. Chemical Analysis
3. Microbiological Analysis

11.1 TEMPERATURES

To save space individual recordings are not tabulated in this report. The figures listed below records the average and highest temperatures attained during the windrow maturation period. Each windrow was monitored at eight fixed positions.

WINDROW NO	START UP DATE	AVERAGE	HIGHEST	AMBIENT
1	10 May 1992	56oC	69oC	15oC
2	22 May 1992	51oC	62oC	
3 & 4	10 Aug 1992	50oC	62oC	24oC
5 & 6	9 Sep 1992	54oC	64oC	26oC
7 & 8	6 Oct 1992	55oC	62oC	28oC
9 & 10	2 Nov 1992	58oC	66oC	28oC
11 & 12	15 Dec 1992	52oC	60oC	30oC
13 to 17	2 Feb 1993	58oC	71oC	30oC
			(2/2	40oC)
18 to 22	3 Mar 1993	54oC	65oC	28oC
23 to 27	7 Apr 1993	56oC	73oC	24oC

11.2 CHEMICAL ANALYSIS

During the course of the project samples were submitted to the Laboratories of L.I.R.I. Technologies at Rhodes University. The ash content of this random analysis was extremely high. The reason for this could be that the cover material used for windrow insulation contained a high degree of soil together with a dust content from the refuse. In addition the windrows were not built on a concrete base. Some soil would have been scooped up when front-end loaders cleared away the fully matured and stabilised windrow material prior to sieving. Mercury and lead levels should be checked in later analysis.

11.3 MICROBIOLOGICAL ANALYSIS

The listed results of analysis carried out on the 23 July 1992 and 7 September 1992 are listed in the Annexures and are self explanatory and satisfactory.

Further analysis of samples taken in March 1993 gave similar pathogenic results.

12. PROJECT EVALUATION

Duration of Project Full Scale Conditions : 20 May 1992 to 30 April 1993. All figures are approximate.

12.1	Total domestic refuse delivered to the sewage works	: 3600 cu/m
*	Potential volume of domestic refuse generated by Rini population in study period	: 12 000 cu/m
*	Percentage volume of total refuse treated	: 30%
*	Number of windrows built in project period	: 30 windrows
*	Volume of domestic refuse per windrow At end of windrow treatment this volume subsides to about 80 cubic metres	: 120 cu/m
*	Number of bags of organic material screened out of each windrow	: 400 bags
*	Wood chips supplied by Parks & Gardens Grahamstown was added to most windrows as additional bulking	: 80 cu/m

11.

- * Average yield per windrow : 45%
 - * Volume of maturing material on site.
This includes material in five windrows
plus material awaiting screening : 950cu/m
 - * Volume of screened organic material -
(growing medium) on site : 400 cu/m
 - * Volume of growing medium donated to
Parks & Gardens Dept. Grahamstown in
exchange for wood chips : 40 cu/m
- 12.2 NIGHTSOIL (PRIMARY SEWAGE SLUDGE)
- * Volume of primary sludge sprayed onto
each windrow : 18,000
litres
 - * Total volume of primary sludge sprayed
over 30 windrows : 540,000
litres
 - * Total solids organic material from
sludge per windrow : 720 kgs
- 12.3 OTHER MATERIAL FOR RECYCLING
- * Plastic
 - * 90 bales of plastic have been compressed and baled.
The total volume is estimated at 50 cubic metres.
 - * Glass
- Not more than one cubic metre has been collected. The original research carried out on refuse from Rini as measured at the Grahamstown Landfill site over a period of one year showed that each cubic metre of refuse would contain about 8% of glass. We should have collected over 250 cubic metres of glass; obviously it has been recycled by the workers for their own account!
- 12.4 The present equipment and staff should have completed approximately 44 windrows during the pilot study period. The reasons for the shortfall are various:-
- * Plant shutdown during times of unrest.
 - * Equipment breakdown with prolonged delays in repairs; e.g. emascerator pump breakdown, with no standby pump caused a delay of at least three weeks.

- * Indecision by Rini Town Council caused staff demotivation and therefore a lack of control and decisive management by the staff.
- * Had the target of 44 windrows been achieved, about 50% of Rini's total domestic refuse would have been processed through the system.

12.5 FINANCIAL IMPLICATIONS

COST EFFECTIVE SAVINGS ON THE THREE SCENARIOS

- (a) The actuality of 30 windrows.
- (b) The potential budgeted 44 windrows.
- (c) The total process of Rini's domestic waste - 90 windrows per annum.

COST SAVINGS ON TRANSPORT OF TRACTOR TRAILER SYSTEM:-

Estimated expenditure saving of two hours per day load at R34.00 per hour (maintenance costs).

30 windrows	=	720 loads
44 windrows	=	1056 loads
90 windrows	=	2160 loads
720 x 34 x 2	=	R48.960
1056 x 34 x 2	=	R72.808
2160 x 34 x 2	=	R214.880

Transport Labour Cost Saving :- 2 hours can be saved per day at R30/hour.

30 WINDROWS	44 WINDROWS	90 WINDROWS
-------------	-------------	-------------

R21.600 p.a.	R31.680 p.a.	R64.800 p.a.
--------------	--------------	--------------

Saving on landfill levy to Grahamstown Municipality.

R7.000	R11.000	R22.000
--------	---------	---------

Sale of growing medium nominal R20/cubic metre.

R28.000	R42.000	R84.000
---------	---------	---------

Totals - gross savings :-

R105.560	R157.488	R385.680
----------	----------	----------

Additional Labour Costs :-

R40.942	R60.000	R120.000
---------	---------	----------

Nett Savings :-

R64.418	R97.488	R265.680
---------	---------	----------

Savings on Tractor :-

R300.000	R300.00	R300.000
----------	---------	----------

R364.418	R397.488	R565.680
----------	----------	----------

No account was taken of cost of protective clothing for the staff or the use of the front-end loader, nor any income derived from the sale of baled plastic.

12.6 Estimated Expenditure For Additional Equipment To Treat 100% of Rini's Nightsoil and Domestic Refuse.

3 Fan Blowers	:	R12.000
Electric Equipment	:	R10.000
Aeration Pipes or Pellets	:	R5.000
Secondhand frontend loader	:	R47.000
Rotary Screens	:	R20.000
		<hr/>
TOTAL	:	R87.000

The additional benefit would be that instead of the present labour force staying at 10 extra workers, an additional 20 job opportunities would become available.

12.7 THE CONCERN OF HEAVY METALS IN SEWAGE SLUDGE

Previous concern of these heavy metals gaining access to the food chain by the spread of sewage sludge and related products onto agricultural land is unfounded as proved by report submitted in the Addendum by Thomas H Wright of University of Wisconsin, Madison, September 1992. Any legislation as stipulated by the Department of Agriculture or Health should be amended accordingly.

12.8 THE RINI DOMESTIC REFUSE REMOVAL FLEET

This consists of six tractor trailer systems. All of these vehicles are old and will shortly have to be replaced.

To replace all six units would cost at a conservative estimate, approximately R600.00.

- 12.9 It is heard unofficially that it is the intention of the Rini Town Council to move this nightsoil treatment plant at some future date. The project equipment is capable of being moved to the new site. It is not for this report to question such a Council decision.
- 12.10 It is hoped that The Algoa Regional Services Council will protect its investment and ensure that this unique plant will continue to operate. It is the first of its kind in the World. The interest in its operation has drawn visitors from all over South Africa and from international agencies based in Switzerland and Germany. The scientific paper read on this project at Toronto, Canada, was eventually published in the worldwide journal - Water Technology. See Annexure.

13. CONCLUSION

- 13.1 The project has demonstrated that the stabilisation of nightsoil (raw sewage) using unsorted domestic refuse as a bulking agent, is economically feasible as a low cost means of treating these two obnoxious waste streams, on a comparatively large scale.

The process makes use of natural biological means to treat these waste streams instead of involving communities in the financial responsibility to high cost, high energy schemes that require highly trained technical staff to maintain the systems.

The Rini plant is capable of being maintained by unskilled workers.

- 13.2 The use of domestic refuse in the process reduces transport costs in the case of Rini to low levels.
- 13.3 More importantly the use of domestic refuse as a bulking agent will increase the life of the Grahamstown landfill site by a significant number of years.
- 13.4 If this process were to become widely accepted and put into operation, it would, by reducing volumes in landfill sites, have a positive effect in the reduction of leachate from landfill areas. This would, in turn, benefit ground water quality, and have similar beneficial effects on neighbouring streams, rivers and lakes.
- 13.5 The system is environmentally friendly.

REFERENCES

- * ALEXANDER, W.V. and TOERIEN, D.F. (1985) : The potential for artificial reedbeds for the treatment of waste waters in Southern Africa. In Proc. Seminar on Technology Transfer in Water Supply and Sanitation in Developing areas. King Williams's Town. February.
- * NELL, J.H. and ROSS, W.R. (1987) : Forced-aeration composting of sewage sludge. Prototype Study. Contract Report to the Water Research Commission by the National Institute for Water Research of the CSIR. WRC Report No. 101/1/87. 250p.
- * ROSS, W.R., NELL, J.H. and PALMER, I.H. (1986) : Design and cost of forced aeration stabilisation unit operations. Proc. Technology Transfer Seminar on Forced Aeration Stabilisation (composting) and Disinfection of Sewage Sludge. Bellville Civic Centre, Bellville, 9 July, 37 - 67. Water Research Commission and NIWR of CSIR.
- * ROSS, W.R. (1990) : Co-disposal of sewage sludge and refuse in a sanitary landfill bioreactor. Municipal Engineer, 21 (6).
- * USEPA (1981) : Composting process to stabilise and disinfect municipal sewage sludges. EPA Technical Bulletin 430/9-81-011, USEPA, Office of Water Program Operations.
- * WILLSON, G.B., PARR, J.F., EPSTEIN, E., MARSH, P.B., CHANEY, R.L., COLACICCO, D., BERGE, W.D., SUKORA, L.J., TESTER, C.F. and HONICK, S. (1980) : Manual for composting sewage sludge by the Beltsville aerated-pile method. EPA Report No : 600/8-80-022. May, Cincinnati Ohio, 65p.
- * WILLSON, G.B. (1986) : Personal communication. United States Department of Agriculture at Beltsville, Maryland.
- * LA TROBE, B.E., ROSS, W.R. (1990) : Forced Aeration Co-Composting of Domestic Refuse and Nightsoil at Rini, Grahamstown. Contract Report to W.R.C., Pretoria, S.A. 33P.

- * NELL, J.H., TOSS, W.R. (1987) : Foreced Aeration Composting of Sewage Sludge: Prototype Study, Contract Report to W.R.C. by the National Institute Water Reasearch of the C.S.I.R., Pretoria, S.A. Report No : 101/1/87., 250 P.
- * BENEDICT, A.H., EPSTEIN, E., ALPERT, J. Composting Municipal Sludge (1987), New Jersey, U.S.A.
- * WALKER, J., GOLDSTEIN, N., CHEN, B. Evaluating the In-Vessel Composting Option. The Art & Science of Composting Journal of Waste Recycling.

AUTHORS ADDRESSES

B.E. LA TROBE
La Trobe & Associates
P O Box 52303
SAXONWOLD
2132

W.R. ROSS
Ross Consultancy
P O Box 3483
TYGERPARK
7536

TEL: 011 880-7690
FAX: 011 788-1098

TEL: 021 99-6453
FAX: 021 99-4707

17.

A N N E X U R E S

WASTE GAS ENGINEERING
(Pty) Ltd
 Reg. No. 89/03290/07
 Engineering Construction - Anaerobic Digestors
 Waste Gas Technical Services

XXXXXXXXXX XXXXXXXXXX XXXXXXXXXX XXXXXXXXXX	74 Charles Street Grahamstown 6140 Tel: (0461) 23575
--	---

7 March 1991

Mr C Muller
 The Town Clerk
 RINI COUNCIL
 P.O. BOX 376
 GRAHAMSTOWN
 6140

re: TREATMENT OF NIGHT SOIL AT RINI.

Dear Mr Muller

This letter is to confirm our discussion at our meeting of the 1st March 1991.

You will recall that I reported to you, that the report Mr E Van Rooyen, Director of Lands, C.P.A., had requested I prepare on the above subject was delivered to his Office about the middle of February 1991.

I was in Cape Town, on other business, on the 19 February, so was able to use the opportunity of visiting Mr Van Rooyen to discuss the report.

Mr Van Rooyen, in turn, set up a meeting for me with members of the C.P.A. Engineering Department. At the end of this meeting it was apparently tentatively agreed by the Engineers to investigate the possible funding of the project under the following conditions.

- 1 The application for this funding must originate from Rini Town Council.
- 2 That the C.P.A. would want to appoint a Co-Project Leader from the C.S.I.R. with the undersigned. This would be at the expense of the C.P.A.
- 3 That the application be accompanied by an economical feasibility study. This document is included with this letter.

In view of the overstressed conditions of Rini Sewage Ponds, the number of complaints regarding the obnoxious smell and the threat of the Dept. of Water Affairs to withdraw the licence of the plant, your Council can be assured that the suggested improvements in the report will alleviate the conditions at the site.

2/-

The Town Clerk
Rini Council

This can be said with confidence in view of the results obtained during the study conducted at Rini Sewage Works during 1990, which was sponsored by the South African Water Research Commission.

A copy of these reports are already in your Office. It is entitled "Forced Aeration Co-Composting of Night Soil and Domestic Refuse at Rini, Grahamstown". The report was published in two sections. The first preliminary section was presented in June 1990 and the final report in January 1991.

The S A Water Commission will continue to assist with funding for the project on the forced aeration composting section to the amount of R30 000 approx. until December 1991.

Should your Council require any further information in order to formulate the application to the Cape Provincial Administration, please contact the undersigned.

Yours faithfully,

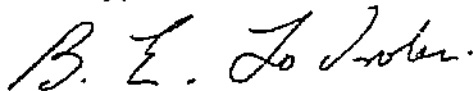

B.E. LA TROBE

26 August 1991

Mr J Kemp
 Director Engineering Services
 Algoa Regional Services Council
 PORT ELIZABETH

re: Treatment of Raw Sewage At Rini, Grahamstown - An Alternative To
 Conventional Sewage Water Treatment.

Dear Mr Kemp,

A copy of a report dated 31 January 1991 is already in your possession. This report describes the pilot study carried out at Rini, Grahamstown over a period of one year (January 1990 to January 1991). This study demonstrated that raw sewage could be successfully stabilised by a process of forced aeration composting using domestic refuse as a bulking agent.

The study was sponsored by The South African Water Research Commission. The Commission considers the process, which is unique to low cost sewage treatment, to have great potential for use in many parts of the Republic.

The Commission is keen to see the process developed further to a full scale operation, and to this end has guaranteed its sponsorship for this purpose, to a total of R50 000. Approximately half of this amount went toward funding of the pilot study and the remainder will cover the costs of the additional research study plus some of the additional equipment on the composting side of the full scale project.

Progress reports to the S A Water Research Commission dated June 90 and Jan 1991 are also in your possession. Should you wish to contact Dr Oliver Hart of the Commission, regarding his impressions on the necessity and viability of this process he may be contacted at Tel: 012 3300340.

You also have a report on the assessment of the potential of the process by Van Wyk & Louw, requested by your Department. Although the undersigned has not seen the report, it was positive.

The S.A. Water Research is not able, in terms of its rules, to fund the total project for equipment, labour etc. on the sewage treatment side of the process. Hence the application by the Rini Town Council, for the sum of R200 000 (Two hundredthousand Rand) to cover the cost of equipment, labour, construction of the night soil treatment plant prior to composting.

Motivation For Installation Of This Plant At Rini.

- 1 The pilot study was carried out at Rini. It therefore makes sense to set up a trial full scale Plant at the same locality - the managerial staff have some experience of the process. The undersigned is close at hand to offer advice, supervision and training of junior staff
- 2 Rini's present night soil treatment plant is in dire straits, being totally overloaded. Installation of this plant will create a permanent solution to Rini's night soil problem.

Mr J Kemp

- 3 It will satisfy the Department of Water Affairs who are threatening to withdraw the present plant's licence.
- 4 It could diminish the threat of legal action from the Eskom establishment which is situated adjacent to the Rini Sewage Works. Eskom because of the mal-odours created at the overloaded sewage works are thinking of moving their entire operation to a different location and claiming damages from Rini Town Council to pay for the relocation.

This will involve a considerable amount of money that will cost millions of rands.

- 5 The establishment of this improved plant will alleviate similar obnoxious problems in a new site and service area which is presently being established close to the sewage works.
- 6 The cost of the solution to this obnoxious problem is relatively inexpensive.
- 7 The experience gained with the establishment of this technique which is known as the CORANS PROCESS, will be of great benefit to Rini and will give the lead to many other Towns of South Africa which suffer with similar problems.
- 8 The process will provide an increase job opportunity in the area and turn two major obnoxious waste streams into a source of income, and also reduce the cost of refuse collection.

Advantages of the CORANS PROCESS.

- 1 It is an appropriate waste management technology which only requires simple equipment and unskilled labour and is suitable for application in less developed areas.
- 2 It is an ecologically acceptable resource recovery method which reduces public health hazards and impacts positively on the environment.
- 3 The integrated composting of refuse with night soil treats two major sources of polluted wastes generated by less developed communities.
- 4 The process recycles nutrients by production of a dry humus-like soil conditioner with a relatively high nitrogen content.
- 5 The high degree of biological heat achieved in the process ensures the disinfection of all pathogens and worm cysts.
- 6 The use of refuse as a bulking agent is more efficient and less costly than other bulking agents, such as wood chips.
- 7 The leachate from the windrows, which is pumped to the ponds is almost free of solids, which will therefore more freely evaporate.

Mr J Kemp.

8. There is a potential income from the sale of the compost as well as the recovered plastic, cans and glass.
9. There are no intrinsic restrictions to the size of the plant.

Note 1 Cost Of The Installation (Stage One)

The Leather Research Report Annexure III (in your possession) lists three different stages of plant improvement. Only stage 1 is necessary to solve the immediate problem the rest might be established later with funding from other Sources. However, should this occur, the works will become a model for the possibility of producing cattle feed, very important in times of drought and general feeding for Rini's cattle owners who are always having trouble feeding their stock. It will also, in turn, create more work.

Note 2

Prices listed were as of January 1991. With present day inflation there has obviously been increases. New up to date prices have recently been requested. These will be faxed to your Office. However, the built in contingency figure of 15% should help to defray the additional cost and help keep the project within the requested application from Rini of R200 000.

Budget Estimate:

Design	
Supervision	
Training	
Transport Costs	Total = R 45, 428-00
Monitoring	
Chemical Analysis	
Consultant's Fees	

Equipment:

Rotary Sieves, Aeration Piping _ Fan Blowers	10, 350-00
Screen	25, 000-00
Sump	10, 000-00
Pump and Controls	8, 000-00
Settling Cone	60, 000-00
Pipework	5, 000-00
Civils	<u>3, 000-00</u>
	R166, 778-00
15% contingency	24, 000-00
Allowance for Increased Construction & installation costs	9, 000-00
	<u>R199, 778-00</u>

Job Creation Potential.

It is estimated that an additional twenty labourers will ultimately be necessary to run the Plant. These persons will be employed in the following capacity. In addition there will be more employment during plant construction.

Mr J Kemp.

- 1 Windrow building (composting lines)
- 2 Control of sewage and refuse mixing.
- 3 Temperature and oxygen monitoring.
- 4 Windrow stripping and sieving after composting.
- 5 Compost bagging.
- 6 Distribution and sale of compost.
- 7 Collection of plastic, glass and tins from compost pile for recycling and sale.
- 8 Collection of remaining inert material to be transported to the refuse site.
- 9 General site maintenance and flying plastic collection.

Later generation of extra employment.

Part of the new project will be the establishment of fast growing hedges around the entire site. This will assist with flying debris, possibly created by refuse windrow formation. It will mask the view of the site and will also tend to absorb residual sewage work odours, which can never be entirely eliminated. Labour will be needed to maintain these hedges, irrigate, trim and extricate the flying debris.

Once the concept of recycling is created and having shown the local population that there is money to be made from the sale of glass and plastic, it will encourage adults and school children to collect these items in and around their town and bring it to the sewage works or a designated local depot, where they will be paid for the glass and plastic that they collect by the kilogram. This material is, in turn, sold to Consol Glass, who pay railage costs, for R93.00/ton and the plastic has a market value of about R0.09 cents/per kilogram.

If the concept becomes popular it will create jobs for many people.

Administration of the Funds.

This has been discussed with the Vice-Chancellor of Rhodes University and its Finance Department, who are prepared to administer the funds through the Dept. of Biotechnology under Prof. J Duncan. The Institute of Leather Research will be responsible for the design and construction of the sludge plant under the direction of Mr Roger Rosewall.

Yours faithfully,

Brian E. La Trobe.

Brian E La Trobe

RECOMMENDED IMPROVEMENTS TO THE NIGHT SOIL DISPOSAL SCHEME AT RINI, GRAHAMSTOWN

ESTIMATED BUDGET FOR STAGE I.

REPORT COSTS	:	R 578 00
ADDITIONAL COMPOSTING EQUIPMENT	:	10350 00
STAFF TRAINING AND SUPERVISION OF THE PROCESS BEFORE HANDING OVER TO RINI STAFF 3 MONTHS AFTER COMMISSIONING. ESTIMATED AT)	9750 00
TRANSPORT COSTS TO AND FROM RINI. 16 KM AT R1,00 km		1200 00
		<u>21,878 00</u>

COST OF SOLIDS REMOVAL:

DESIGN		12 000 00
CONSULTANCY AND TRAINING		18 400 00
MONITORING. SEE APPENDIX I IN THE REPORT FOR MONITORING DETAILS		3 500 00
		<u>R 33 900 00</u>

EQUIPMENT REQUIRED FOR STAGE I. SEE REPORT
ANNEX A FOR DETAILS

R 111 000 00 + 15% contingencies

TOTAL: R 166, 778 00

ESTIMATED SAVINGS:

It is important to state that it is impossible to quantify the value of having turned an overstressed and overloaded toxic smelling sewage system into a more efficient plant, which does not continually get a barrage of complaints from local farmers, passing motorists, local inhabitants and employees of Escom.

COST SAVING IN TRANSPORT OF RINI'S DOMESTIC REFUSE:REFUSE:

The present arrangement is that this refuse is transported to the Grahamstown Landfill Site, a return journey of 18 kms approx. Duration of the round trip is two hours.

Refuse is collected in Rini by six tractor trailer systems. Each vehicle system does two trips a day to the landfill site. The running cost of each vehicle is R14,00 per hour or R28,00 per round trip. Details of these costs:-

12 trips per day	=	R 336 00 per day (travelling time only)
Per 5 day week	=	1 680 00
Per month	=	6 720 00
Per Annum	=	75 040 00

It is envisaged that eventually all Rini's domestic refuse could be treated at the sewage plant. Therefore, the travelling costs of R75 040 00 would be a direct saving less the cost of the reduced travel from Rini to the Sewage Works. This is estimated at a half hour duration :-

R 75 040 00	
- <u>20 160 00</u>	
<u>R 54 880 00</u>	= ACTUAL SAVING.

CAPITAL COST OF TRACTOR TRAILER SYSTEMS:

By elimination of protracted travelling to and from the Grahamstown Landfill Site, the total of twelve hours per day could be reduced to six hours per day.

The extra time gained could be used to collect more refuse and later there would be a saving on reduction of the tractor trailers by two units.

Some of these vehicles are very old, being originally bought in the old Development Board days. The saving of reducing the need to replace two vehicle systems less than the present number would effect a saving on present prices about R200 000 00. The present cost of a tractor is about R80 000 and R20 000 for a trailer.

LABOUR COST SAVING:

Each vehicle unit normally employs a driver and two labourers. With two vehicles less the saving on salaries would be R54 000 00 per annum.

SALE OF COMPOST:

This is not an important factor in the feasibility of the project.

The prime consideration is that the process is transforming toxic raw sewage and toxic waste into a stabilised compost at an extremely economic cost.

In the first instance priority should be given to spreading the end product (compost) on local Township public open spaces, parks or recreational playing fields. The C.S.I.R. report included in the report will prove that it is safe to use compost in this fashion.

It can also be spread on the open space adjacent to the evaporation ponds. If lucerne is planted in this area it could be irrigated with the final contents of the last evaporation pond.

The lucerne could be sold to the local cattle breeders association who are always experiencing problems with cattle feed.

At a conservative estimate the plant would be capable of producing at least ten tons of compost a month. To sell the product on the open market, it will be necessary to have an analysis of the compost and to have a method of bagging and weighing the compost.

This can be done at a later date, or contract to sell the product in bulk to the local farmers or to the Tyafu Farming Co-Op which is close by at the Fish River.

There is to be a new area of arable land, about 1500 hectares, to be established on the South Bank of the Fish River, once the Glen Melville Sulk Water Scheme comes into operation in 1992. As the soils in this area are known to be of inferior quality, the compost available from Rini should have a ready market for many years into the future.

RECOVERING OF GLASS, PAPER, CARDBOARD, TINS AND PLASTIC.

These estimates are nominal, but are based on the percentage of various components as expressed in the report.

Gross Income Per Annum:

Glass	R3 000 00
Plastic	5 000 00
Paper & Cardboard	2 000 00
Tins	<u>2 000 00</u>
TOTAL :	<u>R12 000 00</u>

SUMMARY OF FEASIBILITY:Potential Saving:

1	Travelling Time Savings	R 54 880 00		
2	Savings on Tractor/Trailers	200 000 00		
3	Savings on Labour Cost	54 000 00		
4	Revenue on sale of compost only three yrs after commissioning	12 000 00	per annum nominal	
5	Income from recovery of glass, plastic etc.	12 000 00	" " "	
	TOTAL =	<u>R 332 880 00</u>		

TOTAL COST OF PROJECT, PHASE I R 166 778 00

The pay back period would be about two years and dramatically less, if cost of replacement of two tractor/trailer systems was taken into account in the first year after commissioning of the Plant.

7 MARCH 1991

**LIRI TECHNOLOGIES**

P.O. BOX 185
GRAHAMSTOWN
6140
SOUTH AFRICA

PHONE (0481) 2-7310
FAX (0481) 2-6517
TELEGRAMS LIRI

Incorporated Association not for gain
Reg No 005/0683/08

16 July 1991

Dr B Latrobe
74 Charles Street
GRAHAMSTOWN
6140

Dear Mr Latrobe

re: SETTLING OF RINI NIGHT-SOIL EFFLUENT

Please find attached LIRI/RPT 1602 regarding the settlement of night-soil from Rini disposal works.

The solids and moisture contents of the various samples, after settling, are given.

Kind Regards

Yours Sincerely

A handwritten signature in cursive script that reads 'R A Rowsell'.

MR R A ROWSWELL
Manager
Environmental Division

LIRI TECHNOLOGIESLIRI/RPT 1602July 1991SETTLEMENT OF NIGHT SOIL FROM RINI DISPOSAL WORKS

by

R A ROWSWELL and B E STONE

A raw sample of night soil effluent was received from the Rini disposal works for sedimentation trials.

Three, one litre, samples were decanted into 1 litre measuring cylinders for settling over a time period of:

- 1) 1 hour; 2) 2 hours; and 3) Overnight (15h00 - 08h00) 17 hours.

Small aliquots were taken at specific time intervals at the top (900ml mark) middle (500ml mark) and bottom (50ml mark) for analysis. Solids and Moisture content were then determined to establish the degree of settling taking place. The results were as follows:

Analysis of Night-soil Samples after Settling

Measuring Cylinder	Sample	Time	Moisture	Total Solids
1	R1T	1hr	94,70%	52 960 mg/l
	R1M	1hr	94,57%	54 280 mg/l
	R1B	1hr	93,99%	60 140 mg/l
2	R2T	2hrs	93,76%	62 440 mg/l
	R2M	2hrs	93,83%	61 700 mg/l
	R2B	2hrs	94,14%	58 620 mg/l
3	R3T	17hrs	93,68%	63 140 mg/l
	R3M	17hrs	95,88%	41 180 mg/l
	R3B	17hrs	93,98%	60 220 mg/l
1	R4T	17hrs	95,58%	44 180 mg/l
	R4M	17hrs	96,45%	35 520 mg/l
	R4B	17hrs	93,87%	61 260 mg/l

-2-

Notes regarding the sampling of settled night-soil

The sample of night soil received, contained solids particles significantly larger than would be obtained had the recommended processes, namely a macerating pump and rotary screen, been installed. These larger particles made accurate sampling difficult to carry out.

Samples of approximately 10 - 15ml were extracted at the various levels described above with a glass tube of approximately 5mm internal diameter to avoid blocking up. Pipetting was found to be impossible.

The observation was made that after overnight settling there was a noted quantity of larger solids which had floated to the top. Again this should not occur after the above mentioned recommended preliminary treatment which would reduce the larger solids to a more consistent sludge (macerator pump) and that the remaining larger solid would be removed by screening (rotary screen).

After overnight settling the liquors, in all three measuring cylinders, showed the following characteristics.

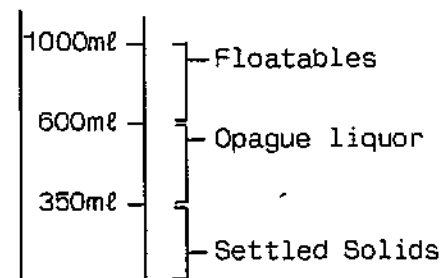

Samples R3T to R3B and R4T to R4B were taken from measuring cylinders 3 and 1 respectively. From the results it is noted that, as samples R1T to R1B and R4T to R4B were taken from the same measuring cylinder at different time intervals there is a noted improvement in the degree of settling from after 1 hour to overnight 17 hours. Additionally if the solids had been broken up and screened a far better quality supernatant would have materialized as there would have been a minimum of floatable solids.

The moisture and total solids contents of the sludges are reasonably consistent, 94 - 96% and 6 - 4% respectively.

Solid contents of the night soil effluent (5-6%) is high and should be reduced by primary settling before treatment in an oxidation pond or ditch.

-3-

Enquiry no. D2876

LIRI

16 July 1991

The Institute carries out all tests and/or advises only on the basis that the same are carried out, made or given without any liability whether for negligence or otherwise or for any loss and/or damages sustained by any person from any cause whatsoever arising out of this report.



laboratory services report

LIRI TECHNOLOGIES
 Incorporated Association not for Gain
 Reg. no. 05/030683/08
 P O BOX 185
 GRAHAMSTOWN
 6140

Phone: 0461-27310
 Fax: 0461-26517

FIRM DR B LATROBE
 DATE RECEIVED 22/05/92
 ENQUIRY NO J 0198/0199
 OFFICER B E STONE

8 June 1992

ATTENTION: DR B LATROBE

ANALYSIS OF NIGHTSOIL SEWAGE SAMPLES NO. I and II

ANALYTICAL RESULTS

		I	II
Total Solids	(%)	3,65	4,55
Suspended Solids	(%)	1,18	1,50
Organic Material	(%)	2,88	3,70

B E Stone

B E STONE
 Laboratory Services Division

Focused on meeting our members' needs

laboratory services report



LIRI TECHNOLOGIES

P.O. BOX 185
GRAHAMSTOWN
6140
SOUTH AFRICA

PHONE: (0461) 2-7310
FAX: (0461) 2-6517

Incorporated Association not for Gain
Reg no 005/030683/C8

FIRM DR B LATROBE
DATE RECEIVED 25/8/92
ENQUIRY NO D4203
OFFICER W M FOWLER

2 September 1992

ATTENTION DR B LATROBE
ANALYSIS OF COMPOSTING SAMPLE
REF SAMPLE DELIVERED PERSONALLY ON 25/8/92.

ANALYTICAL RESULTS

pH			7,2
Moisture Content		(%)	15,1
Ash Content		(%)	76,7
Total Kjeldahl Nitrogen		(g/kg)	3,0
Phosphate	as P	(g/kg)	0,3
Potassium	as K	(g/kg)	5,5
Calcium	as Ca	(g/kg)	4,8
Magnesium	as Mg	(g/kg)	1,7
Iron	as Fe	(g/kg)	28,3
Sulphur	as S	(g/kg)	3,1
Cadmium	as Cd	(g/kg)	<0,002
Cobalt	as Co	(g/kg)	<0,001
Chrome	as Cr	(g/kg)	<0,002
Copper	as Cu	(g/kg)	0,003
Manganese	as Mn	(g/kg)	0,280
Molybdenum	as Mo	(g/kg)	<0,002
Nickle	as Ni	(g/kg)	0,003
Zinc	as Zn	(g/kg)	3,10
Boron	as B	(g/kg)	0,003
Mercury	as Hg	Not analysed for	
Lead	as Pb	Not analysed for	

Note: All values are expressed on a wet basis as either percentage or as grams per kilogram.

NOTE: The results and comments refer to the samples tested and are subject to the normal determinants of sampling error. These samples may not necessarily be representative of the batches from which they were taken, nor of any future consignments of the materials.

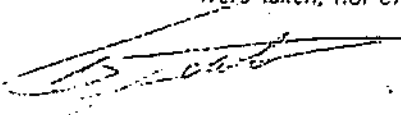
DR W M FOWLER
Manager
Laboratory Services Division



LIRI TECHNOLOGIES
 P.O. BOX 185
 GRAHAMSTOWN
 6140
 SOUTH AFRICA

PHONE: (0481) 2-7310
 FAX: (0481) 2-6517

Incorporated Association not for Gain
 Reg no 005/030683/08

LIRI/RPT MS 7/92 (Week 29)

23 July 1992

MICROBIOLOGICAL EXAMINATION OF COMPOST SAMPLES
 FOR DR B LA TROBE

by

A GUTHRIE

SAMPLE	SALMONELLA	ASCARIS OVA
Johannesburg Market	NIL	NIL
Rini Sewage Works	NIL	NIL



LIRI TECHNOLOGIES
P.O. BOX 185
GRAHAMSTOWN
6140
SOUTH AFRICA

PHONE: (0461) 2-7310
FAX: (0461) 2-6517

Incorporated Association not for Gain
Reg no 005/Q30663/Q8

LIRI/RPT MS11/92 (Week 29)

7 September 1992

MICROBIOLOGICAL EXAMINATION OF COMPOST SAMPLES
FOR ALGOA REGIONAL SERVICES COUNCIL

by

A GUTHRIE

SAMPLE	SALMONELLA	ASCARIS OVA
Rini Sewage Works	Nil	Nil

LA TROBE & ASSOCIATES RINI COMPOSTING GRAHAMSTOWN

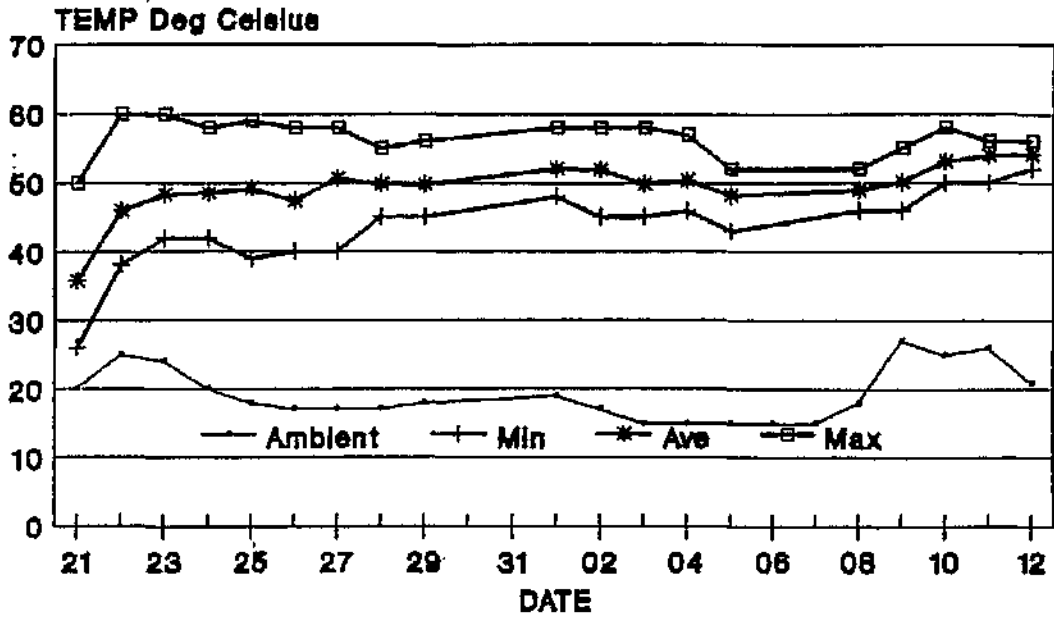

Windrow no.1 : 21 May - 12 June 1992

LA TROBE & ASSOCIATES RINI COMPOSTING GRAHAMSTOWN

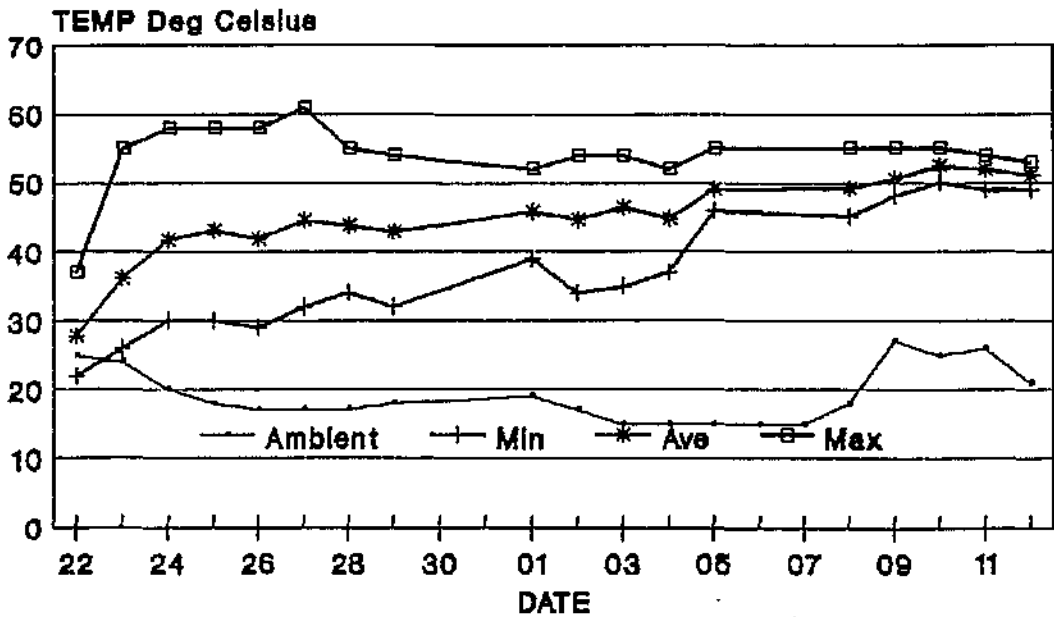

Windrow no.2 : 22 May - 12 June 1992

TREATMENT OF RAW
SEWAGE AT RINI GRAHAMSTOWN
AN ALTERNATIVE TO
CONVENTIONAL WATER TREATMENT

DR. B E LA TROBE

THE TREATMENT OF RAW SEWERAGE AT RINI NEAR GRAHAMSTOWN

THE RINI BOUNDARIES AND THE TOWN'S STATUS

Rini is presently controlled by its Black Town Council, with its own Local Authority Staff. The Town Clerk is Mr. C Müller.

The town borders on the road to Fort Beaufort and is limited by the farm Mayfield, the old road from Grahamstown to East London and extends down to Middle Terrace, off Raglan Road.

THE PRESENT SYSTEM OM RAW SEWERAGE COLLECTION AND TREATMENT

Fingo Village and parts of the area known as Tantjie are served by waterborne sewage which drains into the Grahamstown City water treatment plant.

Most of the town is serviced by a nightsoil bucket system. The remainder, mainly the area known as extension five, which contains the more recent and expensive housing development, has a system of conservancy tanks which are drained periodically.

The charge for drainage of these tanks is fairly high, but I am led to believe that few people pay as a protest to their profound dislike of the conservancy tank system.

Using a conservancy tank system for the Rini area, displayed an unfortunate disregard for the local conditions and geology.

Rini is built on a solid slab of clay which is subject to ground movement. Many of these tanks cracked, with the resultant leakage of the contents.

Neighbours share conservancy tanks with expected arguments, as to who causes the tank to fill quicker etc. When the tanks are evacuated the smell is horrendous.

There is an added complication. The contents of Conservancy tanks is either discharged into a sewer which drains into the Grahamstown works, where it complicates sewerage treatment in an already overloaded works, or it is discharged into Rini's own evaporation Pond System. This pond system is also in an overloaded and overstressed state. The system attempts to purify the night soil by forced aerating it. When the contents of the conservancy tanks is discharged into the ponds it is already in an anaerobic phase, which defeats the attempt to purify the sewage by aerobic techniques.

THE RINI SEWAGE EVAPORATION POND SYSTEM

Nightsoil is delivered by various capacity sized trucks. The total volume delivered to the works is probably between 3.0 kilolitres to 3.5 kilolitres per day. The system was designed to treat between one third to one half of that volume.

When these statements were made, I am confident that the two gentlemen concerned have not seen the condition of these ponds for some considerable time. Also if the solution to the problem was so simple why had it not been tried before? The ponds have been in this condition for a long time.

I do not blame the Rini Staff. They have lacked the proper direction. In fact Mr. A Brown has made a valiant attempt to improve the situation but to no avail. I am prepared to come out categorically against additional aeration as suggested by the Consultants, and I would plead that no further money be wasted on buying additional aerators.

I am not alone in this suggestion. My opinion is backed by the following who have visited the site:-

1. Dr. O Hart of the S A Water Research Commission
2. Dr. P Odendaal, Chief Executive of the S A Water Research Commission
3. Prof. R Kirby, Head of Microbiology, Rhodes University
4. Mr. P Rose, Microbiology, Rhodes University
5. Mr. R Rosewall, Leather Research Institute
6. Mr. R Theron, Chief Health Officer, Grahamstown
7. Mr. T Nel, Regional Health Department, Port Elizabeth

It has also been suggested by Ninham Shand that the present system should be relocated to a different site or it should be planned that Rini should be sewerred with a water bourne system and that the treatment plant for this effluent from this system should be treated at a plant to be established on the farm Mayfield, when it is purchased for the further development of Rini. The cost of this plant some two year ago was estimated at approximately R9 million. This figure is quoted from memory, but nevertheless it was a large amount.

I pose the question, will the inhabitants of Rini, be able to afford such an expansion system? With the rapid changes in the laws of the land, the change in political structures, and present day financial climates, will the purchase of Mayfield ever be an option in the forseable future?

In fairness to Ninham Shand, this section of their planning was conducted before the dramatic changes in this country started to occur.

And finally would it be wise merely relocate the present Pond System? Surely this would only transfer the present problems from one place to another.

Another option would be for Rini to be sewerred and the effluent transferred to the Grahamstown Water Treatment Plant. If this idea was accepted there would be two expensive complications.

- a) There is a high point running through Rini which creates a watershed; this would require the pumping of sewage on the remote side of the high point, before it would gravitate to the present works - that would be expensive.

- 2) To remove a large proportion of the solids from the night solid at the works by deviating the incoming flow into a cone separation settling tank. After a determined setting period, surface liquid will be returned to the ponds. The settled solids will be combined with domestic refuse from Rini, which will be force aerated to produce compost within a duration of one month to six weeks.

I have every confidence of the success of the project, as it has been well researched over the past year. A copy of the report has been lodged with Rini City Council.

The treatment of a proportion of the solids in this manner will relieve the stress in the Pond System which will then again be able to treat the incoming night soil flow in a efficient manner, which will result in minimal odour problems.

There are other advantages to this form of treatment of the night soil with the local domestic refuse.

- 1) At the end of the process one ends up with the product which is not only stable but of use to the local community, and can be used to fertilize its gardens, parks and Public Open spaces. It can also be bagged and offered for sale on the open market.

The concern of possible infection from residual pathogenic bacteria does not apply. The process used, builds up tremendous biological heat (temperatures of approximately 70 °C) which kills off all pathological bacteria and all worm cysts such as Ascaris.

- 2) With time, over the Medium term, it will be possible to treat the major portion of the towns domestic refuse in this way. At present Rini transports all its refuse to the Grahamstown Landfill Site - a round trip of nearly 20 kilometres per tractor trailer system. It could effect a saving in the purchase of diesel fuel in excess of R100 000,00 per annum, which would pay for the cost of the upgrading of the works in less than 3 years.

There is also the saving of sale of the glass, plastic and tins retrieved from the compost. Glass alone is bought by Consol Glass at the present rate of R93,00 per ton. There is also a market for the plastic.

My research also included the percentage of the various components of Rini's domestic waste, This was carried out by construction of a wood box, the volume of which was exactly one cubic metre. The box was filled from a refuse truck from Rini. The refuse from the box was then handsorted, into various individual bags and finally weighed with a spring scale. The average result was as follows:-

Glass	Plastic	Paper	Tins	Organic Matter	Total
15kg	37kg	18kg	7kg	94kg	171kg
88%	21.6%	10.5%	4.0kg	55.1%	100%

These samples were tested in December 1989.

Within a very short time after the initiation of the scheme the benefits will become obvious. The ponds will contain very little solid material on the surface of the ponds. The second and third ponds will begin to show high rates of evaporation. In the fullness of time we would change the design of the aerators and experiment with the growing of algae in the evaporation ponds to provide cattle feed for the Cattle Owners Association of Rini. We have the expertise at Rhodes University Microbiology Department to control such a scheme.

If it is agreed by Rini Town Council, the Cape Provincial Administration together with the S A Water Reserve Commission to sponsor this scheme, it can be confidently predicted that we will create a show piece to demonstrate how raw sewage and refuse, can be disposed to the the benefit of the local community. The rest of S A could visit the town to gain firsthand knowledge of this beneficial low cost project.

Costs of Phase One

<u>Production of Report</u>	R 578,00
ADDITIONAL COMPOSTING EQUIPMENT	R 10 350,00
Staff Training and Supervision of process before handing over to Rini staff (3 months after commissioning) approximately 25 hours per month	R 9 750,00
Transport costs to and from Rini 16 kms & R1,00/km	R 1 200,00
	<u>R 21 878,00</u>

COST OF SOLIDS REMOVAL

See LIRI Report

Budget Consting	R 33 900,00
Stage I only + 15% Contingencies	<u>R111 000,00</u>
TOTAL	<u>R166 778,00</u>

STAGES II AND III

This will only be necessary if the decision is made to embark on the process of growing algae on the ponds as a cattle feed for the Rini Cattle Owners Association or per general sale.

8. To all intents and purposes it offers the same as a waterbourne sewage system.
9. It would lower the site and service charges, as the expensive nightsoil trucks and buckets would gradually be phased out.
10. The system is easy to install with unskilled labour. Even the small bore effluent pipe system is not costly as it only transports clear liquids. The final treatment of this liquid is carried out with certain plants, fishes and snails.
11. Maintenance is extremely low because of the "liquids only" situation.
12. The final treatment does not require day to day attendance by highly trained staff.
13. If the digester is blocked or ill treated by the owner it does not affect his neighbours, and can only blame himself. The same damage is not likely to occur a second time.
14. The toilet can be installed within the house or shack, eliminating the depressing sight of row upon row of "kleinhuisies".
15. In times of civil unrest or strikes, the system keeps on working, therefore the community is not subject to the revulsion of over filled, smelly buckets, which are eventually tipped into storm water drains or water courses with the resultant pollution and Health problems

The Transvaal Provincial Administration have already installed over two thousand five hundred of these units. It would be wise for Municipal Engineers of this area to pay a visit to view the success of these installations. It is well known that some digesters have been marketed in South Africa that have failed for various mechanical reasons. This can be avoided by studying the track record of the various types.

The system itself is well proven and is ideal for local South Africa conditions, where water is expensive and invariably in short supply.

The system is not only a solution for low cost sub-economic areas, but also in areas along our coast line where all sorts of real estate developments are continuing ahead of the necessary infrastructure, particularly sewage in holiday areas where the Local Authority cannot afford conventional water treatment plants.

FORCED AERATION COMPOSTING RECOVERS WASTES

Recycling Domestic Refuse and Night Soil in South Africa

Brian E. La Trobe, W.R. Ross

In South Africa, adequate disposal systems for sanitary wastes and domestic refuse are lacking because of demographic, sociological, and economic factors. This situation has resulted in an urgent need for low-cost waste-management technologies. This need is particularly felt in rural communities and in overpopulated outskirts of urban areas, where many people are settling in search of better work opportunities.

Sanitary waste disposal in developing areas of South Africa is generally by means of the bucket system, as there is no infrastructure for wastewater and there is often a chronic water shortage. The wastes and paper—"night soil"—from these buckets are usually disposed of in lagoons, which must be situated some distance from the community because of odor and fly breeding problems. Domestic refuse, which is a complex conglomerate of organic and inorganic materials, is often disposed of by uncontrolled landfilling, which adversely affects the environment.

Forced aeration composting of night soil with unpulverized refuse as a bulking and filtering agent may be cost-effective for stabilizing, disinfecting, and recovering these two polluting waste streams (see Box *Forced Aeration Composting History*, Figure 1).

COMPOSTING DOMESTIC REFUSE AND NIGHT SOIL

Pilot-scale composting experiments were carried out at the Rini waste treatment plant outside Grahamstown,

Forced Aeration Composting History

North America. The Biological Waste Management Laboratory at the U.S. Department of Agriculture in Beltsville, Md., began research on composting of wastewater solids during 1972 at the request of the Maryland Environment Service and the Blue Plains Wastewater Treatment Plant in Washington, D.C. This work resulted in a natural-draft windrow method using wood chips as a bulking agent. However, difficulties with odors and low temperatures in the outer layers of the windrows prompted further research. By the middle of 1978, this project had resulted in the development of a successful forced aeration process using static piles.

Since the inception of the process in 1978, more than 400 wastewater solids composting plants have been constructed in North America. Although most of these plants are highly mechanized, the flexibility of the process allows its application in a labor-intensive, non-mechanized form in underdeveloped areas where there is a need for more affordable wastewater treatment processes.

South Africa. The Water Research Commission initiated a project for forced aeration composting of mechanically dewatered primary wastewater solids and wood chips in static piles. The research established the chemical, physical, biological, thermodynamic, and kinetic criteria for properly controlling the process under local conditions. Based on this research, the process is currently being applied at four locations.

South Africa. The facilities used to conduct the composting experiments consisted of several components (Figure 2).

The static piles were constructed by laying an initial 20-cm-thick base layer (4 m × 4 m) of dried stabilized wastewater solids on the concrete slab. The slotted aeration tubing was laid on the base layer and connected to the water trap and aeration fan. A total of 14 m³ of refuse was layered with a total of 3 m³ of night soil to a height of 1.5 m. The refuse acted as a bulking and filter-

ing agent for the night soil solids and was unpulverized so as to use the porosity and structural strength created by the metal cans, plastic containers, and other materials present. Analyses indicated that there was sufficient organic material and moisture (see Box *Moisture Content*) in the refuse to provide energy for biological decomposition.

The pile was covered with a 10-cm layer of dried solids to provide heat insulation and odor control. The free leachate was drained from the pile and

BENEFICIAL USE



An almost-complete windrow of domestic refuse and night soil.

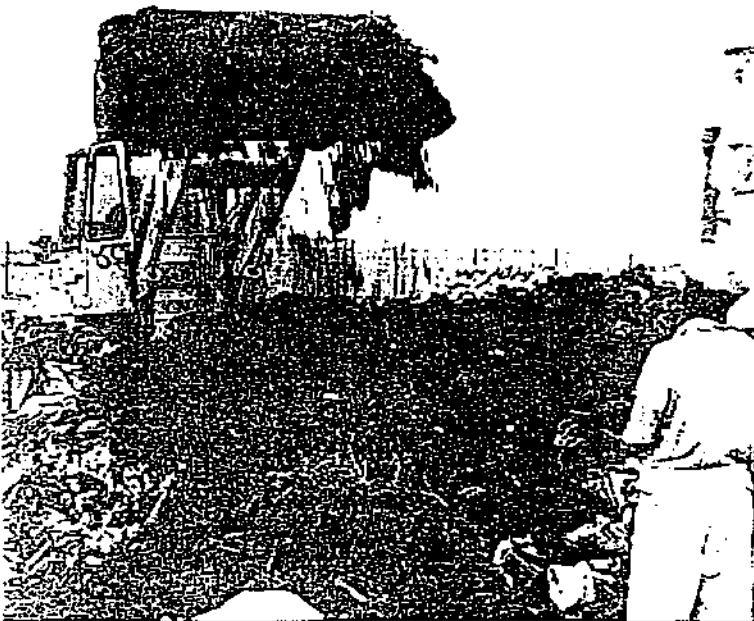

A front-end loader applying the compost insulating blanket before windrow aeration.

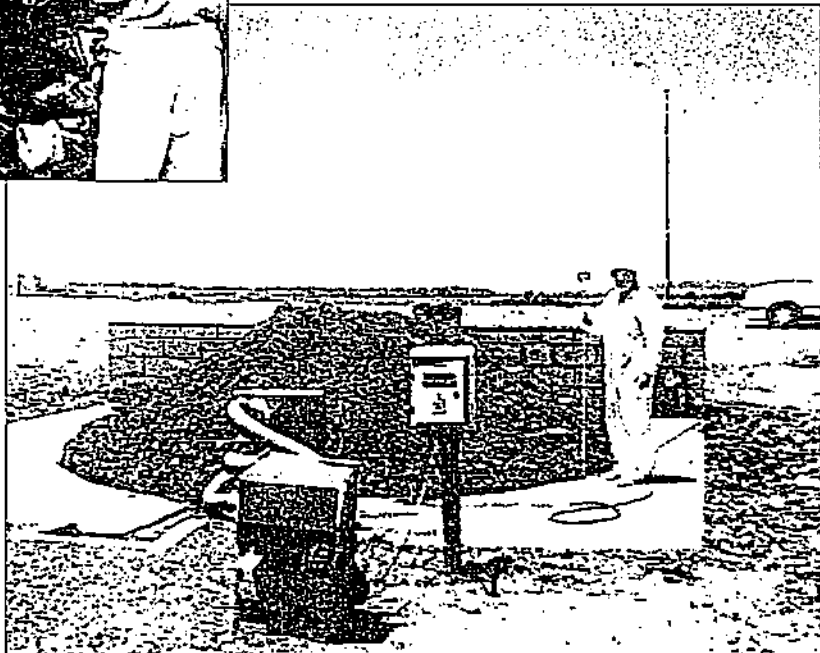

A completed windrow with cover showing radial extraction fan, time switch gear, and water trap. The author is holding the monitoring thermometer.

Photo courtesy of Frank Jellinek

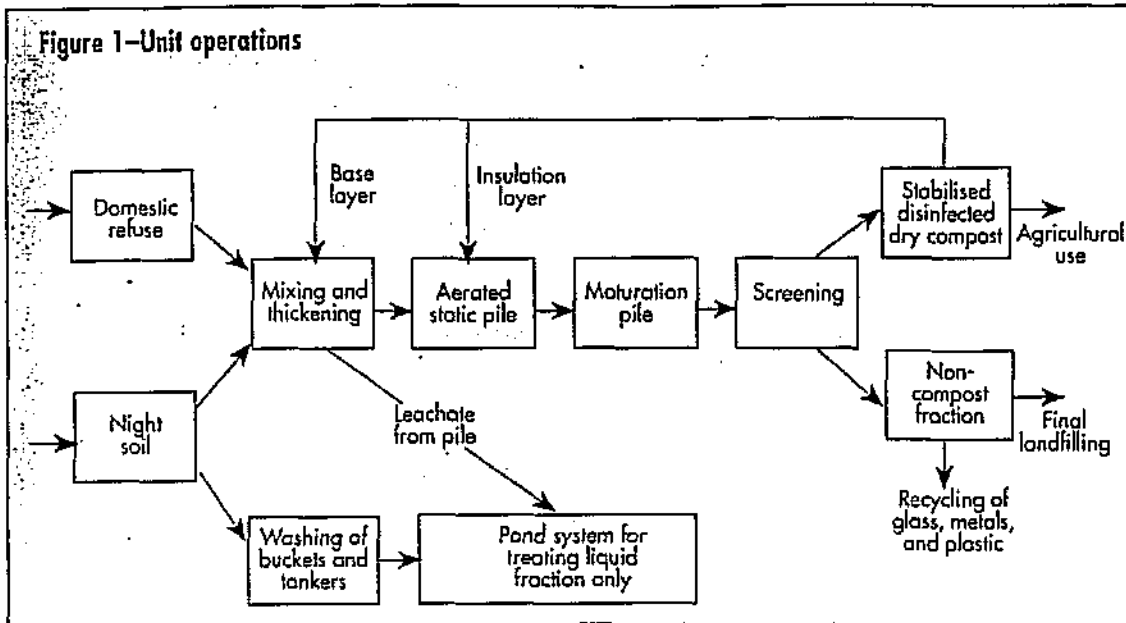

Moisture Content

Refuse is generally rather dry (15% to 20% moisture), but this does not create a problem because the night soil has a moisture content of about 94%. The ideal moisture content of the mixture should be about 60% to 70% at the start of the process. Too much moisture is not satisfactory, as this fills the voids and obstructs the free flow of air.

collected and pumped back to a pond system. Aeration was controlled by a time switch to maintain a residual oxygen concentration of 5% to 15% in the pile. Aeration was maintained at a relatively higher rate ($30 \text{ m}^3 \cdot \text{t}^{-1} \cdot \text{h}^{-1}$) during temperature (t) ascent and at a relatively lower rate ($1.5 \text{ m}^3 \cdot \text{t}^{-1} \cdot \text{h}^{-1}$) once a turning point in the temperature profile was observed. Temperature and residual oxygen levels were monitored routinely. The temperature within the pile should exceed 65°C for at least 5 days to ensure inactivation of all pathogens. After 60 days composting, the pile was manually screened.

PROCESS GIVES STABILIZED SOIL CONDITIONER

There was a rapid increase in temperature from 30° to 68°C 7 days after constructing the static pile. A significant difference in the temperatures inside and outside the pile indicated the biothermal activity of the microorganisms and the energy potential of the composted mixture.

The compost pile (excluding the base and insulation layers) was sieved and the sieved fraction weighed. From an initial

Figure 2—Co-composting Equipment Components

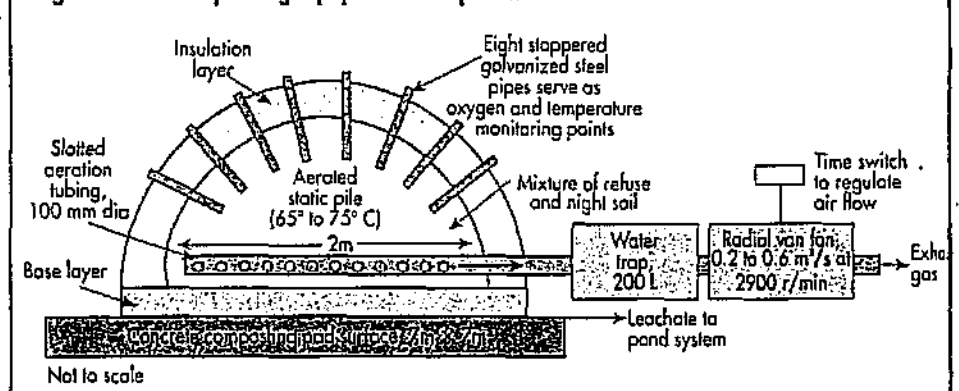

mass of 14 Mg of wet solids, 2.7 Mg of dry solids were recovered. The yield of the final product was calculated to be about 19%.

The composted mixture had a humus-like appearance, was dry, had a loose, friable texture, was black, and had a pleasant earthy smell—nothing like the initial refuse and night soil, which were putrescible and had highly offensive odors.

Although filtering the night soil through the refuse to entrap the solids is a messy procedure, sampling the domestic refuse is difficult, and large pieces of refuse may interfere with the flow of air through the static pile, composting treats polluted wastes using simple equipment and unskilled labor.

The process is ecologically acceptable, recycles nutrients by producing a dry humus-like and stabilized soil conditioner with a relatively high nitrogen content (1.5% to 3%), and reduces public health hazards from pathogens and worm cysts. There are no intrinsic restrictions to the size of the facilities, and

the extended pile method reduces land requirements. Using refuse as a bulking agent provides more energy and costs less than other bulking agents such as wood chips; thus, capital and operating costs are less than for conventional forced aeration composting. There is also potential income from the sale of the compost.

Although the results of experiments indicated that the process is technically feasible, certain aspects require further research before full-scale programs can be implemented. Engineering problems that must be addressed are the layering of the refuse and the night soil to achieve the correct moisture content and porosity of the mixture. The respective volumes of these two waste streams in the final mixture also need to be more accurately quantified.

Brian E. La Trobe is a consultant with LaTrobe Associates in Grahamstown, South Africa; W.R. Ross is a consultant with Ross Consultancy in Tygerpark, South Africa.

EFFECTS OF LIQUID DIGESTED SLUDGE APPLICATION ON THE UPTAKE OF TRACE METALS BY VEGETABLES¹

ABSTRACT

The practice of land application of municipal sewage sludge to agricultural land is an alternative to other methods of disposal. Incineration and landfilling of sewage sludge have been popular in the past but they have come under strong economical and environmental constraints. Land application of sewage sludge is not only economically advantageous and environmentally sound but makes use of resource that has recyclable value. Any potential problems that may surface can be alleviated by careful management practices based on nutrient requirement guidelines established by governing agencies.

Trace metals added to the soil in sewage sludge and their subsequent translocation into edible portions of selected vegetable species was the main focus of this research study.

Specific objectives of this study included:

- 1) To determine the trace metal uptake of cadmium and zinc as well as other trace metals in the edible portion of selected vegetables.
- 2) To determine the effect of sludge application on the yield of vegetable crops and the soil conditions under which they were grown.

To accomplish this research a 5 year field study was conducted on a Mequon silt loam soil utilizing a randomized complete block design with four replicates. Soil treatments consisted of a check, application of liquid digested sewage sludge at rates of 11, 22, and 44, Mg ha⁻¹ (with the 11 Mg ha⁻¹ being the recommended annual rate as well as a residual

¹ Thomas H. Wright, University of Wisconsin-Madison. Department of Soil Science. Presented at the Water Environment Federation 65th Annual Conference & Exposition, New Orleans, LA. September 20-24, 1992.

The vegetables grown were harvested at maturity. This was done by variety and, when harvested, all replicate plots were done at the same time. Overall the yields of the six vegetables were not dramatically increased by the addition of the sludge. After four years of sludge applications, there were still yield responses for bean, cabbage, tomato, and celery as a result of the 11 Mg ha⁻¹ annual treatment. It appears that if there will be any effects from the use of sludge it will occur in the first year after application.

As a result of the sludge applications there were significant increases in the phosphorus level in the soil. Except for cadmium, the trace metals found in the soil are only slightly higher than average levels found across cropland in the United States. Slightly elevated levels of copper and zinc occur in the annual treatment compared to that of the check. Soil cadmium was consistently found to be below the detectable limits of ICP analysis. There was no appreciable change in soil pH, organic matter, or soil potassium as indicated by soil sampling. The higher concentrations of soil copper, nickel, zinc, and lead were found in the 11 Mg ha⁻¹ annual treatment and the one time treatment of 44 Mg ha⁻¹.

Results of this research indicate the ability of liquid digested sewage sludge to be used in the production of green bean, cabbage, celery, onion, tomato, and lettuce while in no case allowing trace metal concentrations to exceed levels for health standards.

Figure 2. Mean trace metal concentrations in vegetables for four years, 1986 - 1989. (n=16)

Vegetable	Soil Treatment†	Cd	Cu	Ni	Zn	Pb
Tomato	1	0.29	14.5	0.59	26.4	1.5
	2	0.23	13.2	0.60	29.1	1.5
	3	0.32	13.7	0.69	28.7	1.6
	4	0.24	13.7	0.82	35.7	1.6
	5	0.31	12.9	0.48	26.9	1.4
	6	0.27	12.6	0.62	27.9	1.5
Bean	1	0.13	10.6	1.6	35.6	1.3
	2	0.14	9.9	2.1	38.8	1.2
	3	0.16	9.2	2.6	37.6	1.3
	4	0.14	8.9	2.0	43.0	1.3
	5	0.15	9.5	1.7	37.1	1.3
	6	0.18	8.8	1.7	37.3	1.4
Onion	1	0.11	7.2	0.35	27.4	1.1
	2	0.09	5.9	0.41	23.6	1.1
	3	0.13	5.6	0.44	24.8	1.4
	4	0.12	5.9	0.39	23.8	1.1
	5	0.10	5.7	0.36	24.2	1.1
	6	0.11	5.6	0.40	20.2	1.1
Cabbage	1	0.14	3.3	0.72	26.2	1.6
	2	0.20	3.5	1.00	30.8	1.6
	3	0.22	3.7	1.20	30.7	1.6
	4	0.19	4.1	1.50	35.9	1.5
	5	0.16	3.2	0.68	28.6	1.4
	6	0.17	3.3	0.74	26.4	1.4

-continued-

Forced aeration co-composting of domestic refuse and night soil

B.E. La Trobe
M.R. Ross



64th Annual
Conference
& Exposition
Toronto • Oct. 7-10, '91

#AC91-022-001

W P C F
Water Pollution Control Federation

Copyright 1991 Water Pollution Control Federation
601 Wythe St., Alexandria, VA 22314-1994
(703) 684-2400, (703) 684-2492 FAX

**FORCED AERATION CO-COMPOSTING OF
DOMESTIC REFUSE AND NIGHT SOIL**

by

B E LA TROBE

and

V R ROSS

PAPER FOR PRESENTATION AT THE
64TH ANNUAL CONFERENCE
of the
WATER POLLUTION CONTROL FEDERATION,
TORONTO, CANADA,
7-10 OCTOBER 1991

FORCED AERATION CO-COMPOSTING OF DOMESTIC REFUSE AND NIGHT SOIL

B E LA TROBE¹ and W R ROSS²

1. 74 Charles Street, Grahamstown 6140, South Africa.
2. Ross Consultancy, P.O. Box 3483, Tygerpark 7536, South Africa.

INTRODUCTION

Sewage and refuse represent the major polluted wastes generated by communities. These wastes have undesirable characteristics, necessitating processing into end-products which will render them environmentally acceptable. While numerous waste treatment options exist, the choice of method of stabilisation is dictated by site-specific criteria. The final decision may be governed by a multitude of variables, including economics, availability of technical skills, water, power and political considerations.

The supply of adequate sanitation systems in developing countries, including South Africa, has deteriorated due to a combination of demographic, sociological and economic factors. This has resulted in an urgent need for the development of low-cost appropriate waste management technologies. This need is particularly felt in sub-economic rural communities, but also in overpopulated outskirts of urban areas, where people are settling in search of better work opportunities.

Sewage disposal in less developed areas is generally by means of the bucket system, as there is no infrastructure for waterborne sewage and often a chronic shortage of water. The night soil arising from these buckets is conventionally disposed of in lagoons which have to be situated some distance from the community, because of the problems of odour and fly breeding. In turn the domestic refuse is often disposed of by uncontrolled landfilling which impacts adversely on the environment.

This paper describes prototype-scale experiments incorporating forced aeration co-composting of night soil with unpulverised refuse as bulking and filtering agent (La Trobe and Ross, 1990). The results illustrate that

the process could be cost effective for stabilisation, disinfection and resource recovery of these two polluting waste streams. The process has been registered under the Trade Name of "CORANS".

HISTORY OF THE CONVENTIONAL FORCED AERATION COMPOSTING PROCESS

North America

The Biological Waste Management Laboratory at the United States Department of Agriculture in Beltsville, Maryland began research on composting (biothermal stabilisation) of sewage sludge during 1972 at the request of the Maryland Environment Service and the Blue Plains Waste-water Treatment Plant in Washington, D.C. This work resulted in 1973 in a natural-draft windrow method utilizing wood chips as a bulking agent. However, difficulties with malodours and low temperatures in the outer layers of the windrows prompted further research at Beltsville sponsored by the United States Environmental Protection Agency (USEPA). By the middle of 1978 this project had resulted in the development of a successful forced aeration process using static piles (Willson et al., 1980).

Since the inception of the process during 1978 more than 400 sewage sludge composting plants have been constructed in North America. Although most of these plants are highly mechanised, the flexibility of the process allows its application in labour-intensive non-mechanised form in underdeveloped areas where there is a need for more affordable sewage treatment processes.

South Africa

The Water Research Commission initiated a project for forced aeration composting of mechanically dewatered primary sewage sludge and wood chips in static piles (Nell and Ross, 1987). The research established the chemical, physical, biological, thermodynamic and kinetic criteria for proper control of the process under local conditions. Based on this research the process is currently being applied at four locations.

EQUIPMENT REQUIRED FOR COMPOSTING OF REFUSE AND NIGHT SOIL

The pilot-scale experiments were carried out at the Rini waste treatment plant, outside Grahamstown, South Africa (La Trobe and Ross, 1990). The facilities used to conduct the composting experiments are illustrated in Figure 1 and were as follows:

- * A concrete slab (7m x 7m) was constructed on which to carry out the experiments. A slight gradient was provided towards a central drainage canal for leachate collection in a sump. The excess leachate was pumped to a pond system.
- * A radial vane fan, capable of 0,2 - 0,6 m³ per second at 2 900 rpm.
- * The aeration manifold tubing (100 mm diameter) was plugged at one end and was perforated over a two metre length to allow air to be drawn into the static pile.
- * A time switch to regulate air flow through the static pile.
- * A 200 litre water trap was constructed with 100 mm inlet and outlet to accommodate the tubing. The drum was provided with a valve to drain the leachate and condensate.
- * A Bacharach Fyrite oxygen analyser.
- * A dial thermometer with 1,5 m long stem.
- * A manually operated sieve with a 25 mm diamond mesh grid.
- * Eight galvanised pipes were driven into the static pile around the perimeter to serve as temperature and residual oxygen monitoring points. A rubber stopper isolated the inside of the pipes from the atmosphere.

SOLID WASTE MATERIALS USED IN THE COMPOSTING EXPERIMENTS

Domestic Refuse

Refuse is a complex conglomerate of organic and inorganic materials. Typical analyses indicated that there was sufficient organic material (55%) in the refuse to provide energy for biological decomposition. The refuse acted as a bulking and filtering agent for the night soil solids and was unpulverised, so as to utilise the porosity and structural strength created by metal cans and plastic containers, etc. Refuse is generally rather dry (15 to 20% moisture) but this does not create a problem because the night soil has a moisture content of some 94%. The ideal moisture content of the mixture should be about 60 to 70% at the start of the process. Too much moisture is not satisfactory as this fills the voids and obstructs the free flow of air.

Night Soil

The chief components of night soil are body wastes and paper. Night soil in its raw state is highly putrescible and rapidly develops strong and offensive odours. The night soil was delivered to the experimental site in a tanker.

The refuse (total volume 14 m³) was laid down in consecutive layers with the night soil (total volume 3 m³) evenly spread over each layer by means of a flexible hose system. The solids content of the night soil was thus thickened by filtration of the liquor through the layers of refuse. The free leachate drained from the pile and was collected and pumped back to a pond system. Such a non-mechanical thickening of the night soil solids considerably reduces the capital and running costs of the CORANS process. In comparison, conventional forced aeration composting processes require mechanically dewatered sludge to be mixed with a more costly bulking agent, such as wood chips.

EXPERIMENTAL PROCEDURES

The prototype-scale static piles were constructed as follows:

- * An initial 20 cm thick base layer (4m x 4m) of dried stabilised sewage sludge was laid on the concrete slab.
- * The aeration slotted/manifold tubing was laid on the base layer and connected to the water trap and aeration fan.
- * Consecutive layers of refuse and night soil were added to a height of 1,5 m. The sides of the static pile were sloped to an angle of about 50 degrees giving a final volume of some 14 m³.
- * The pile was covered with a 10 cm layer of dried sludge to provide heat insulation and odour control. Later test runs used the processed compost as base and insulation layers.
- * The aeration was controlled by a time switch to maintain a residual oxygen concentration of 5 - 15% in the pile. Aeration was maintained at a relatively higher rate (30 m³.t⁻¹.h⁻¹) during temperature ascent and at a relatively lower rate (1,5 m³.t⁻¹.h⁻¹) once a turning point in the temperature profile was observed.
- * Monitoring of temperatures and residual oxygen levels were carried out on a routine basis.
- * After 50 days composting the pile was manually screened.

A process flow diagram of the unit operations for the composting of refuse and night soil is illustrated in Figure 2.

EXPERIMENTAL RESULTS

A typical temperature profile over time (Fig. 3) indicates a rapid increase in temperature from 30 to 68°C in seven days after commissioning of the static pile. The significant difference between the temperatures inside and outside the pile illustrates the biothermal activity of the micro-organisms and the energy potential of the refuse and night soil mixture. The USBPA (1981) recommends that the temperature within the pile should exceed 65°C for at least 5 days to ensure inactivation of all pathogens.

The compost pile (excluding the base and insulation layers) was sieved after the experimental period of 60 days and the sieved fraction was weighed. The yield of final product was arbitrary calculated as follows:

Initial mass of wet solids	= 14 ton (approximate)
Final mass of dry sieved compost	= 2,7 ton
Yield of dry sieved compost	= 19%

The composted mixture of refuse and night soil was easily sieved and had a very good humus-like appearance. The end-product was dry, had a loose friable texture, was black in colour and had a pleasant earthy smell. It was nothing like the initial refuse and night soil which were putrescible and had high offensive malodours.

GENERAL DISCUSSION

Disadvantages of the CORANS process

The filtering of the night soil through the refuse to entrap the solids is a "messy procedure". Operators must take precautions to ensure personal hygiene such as the use of gumboots and gloves.

The heterogenous nature of the domestic refuse makes it difficult to sample. It is therefore difficult to quantify the volumes of refuse and night soil to obtain an ideal mixture. However, with experience this is soon achieved. It would also be advisable to have some measure of

pre-selection of the refuse to remove large cardboard boxes and sheets of plastic which could interfere with the flow of air through the static pile.

Advantages of the CORANS process

- * The integrated composting of refuse with night soil in association with a pond system treats the two major sources of polluted wastes generated by less-developed communities. This appropriate waste management technology only requires simple equipment and unskilled labour.
- * The process is an ecologically acceptable resource recovery method and recycles nutrients by production of a dry humus-like and stabilised soil conditioner with a relatively high nitrogen content (1,5 - 3%).
- * The process reduces public health hazards as the high degree of biological heat generated (60 - 70°C) over a period of some two weeks ensures the inactivation of pathogens and worm cysts.
- * There is a potential income from the sale of the compost as well as the recovered plastic, cans, glass, etc. The use of refuse as a bulking agent provides more energy and is less costly than other bulking agents, such as wood chips.
- * There are no intrinsic restrictions to the size of the plant. Use of the extended pile method reduces the land requirements for composting.

CONCLUSIONS

The result of three prototype-scale test runs have indicated that the biothermal stabilisation (composting) of refuse and night soil by means of forced aeration is technically feasible. The combination of composting for solid wastes and ponds for liquid wastes would be particularly appropriate as a waste management system for less-developed communities, where non-

sophisticated, low-cost and labour-intensive technology is required.

Certain aspects of the process require further research for the full-scale management of the two waste streams. Engineering problems that must be addressed are the sensible mixing (layering) of the refuse and the night soil so as to achieve the correct moisture content and porosity of the mixture. The respective volumes of these two waste streams in the final mixture also need to be more accurately quantified.

ACKNOWLEDGEMENTS

The authors wish to thank the South African Water Research Commission for financing this project and the Rini Town Council for providing the facilities at their waste treatment plant.

REFERENCES

- LA TROBE, BE and ROSS, WR (1990): Forced aeration co-composting of domestic refuse and night soil at Rini, Grahamstown. Contract Report to the Water Research Commission, Pretoria, South Africa. 33p.
- NELL, JH and ROSS, WR (1987): Forced-aeration composting of sewage sludge: Prototype Study. Contract Report to the Water Research Commission by the National Institute for Water Research of the CSIR, Pretoria, South Africa, WRC Report No. 101/1/87, 250p.
- USEPA (1981): Composting process to stabilise and disinfect municipal sewage sludges. EPA Technical Bulletin: 430/9-81-011, USEPA, Office of Water Program Operations, Washington, D.C., 38p.
- WILLSON, GB, PARR, JF, EPSTEIN, D, MARSH, PB, CHANEY, RL, COLACICCO, D, BERGE, WD, SUKORA, LJ, TESTER, CF and HONICK, S. (1980): Manual for composting sewage sludge by the Beltsville aerated-pile method. EPA Report No. 600/8-80-022, May, Cincinnati, Ohio, 65p.

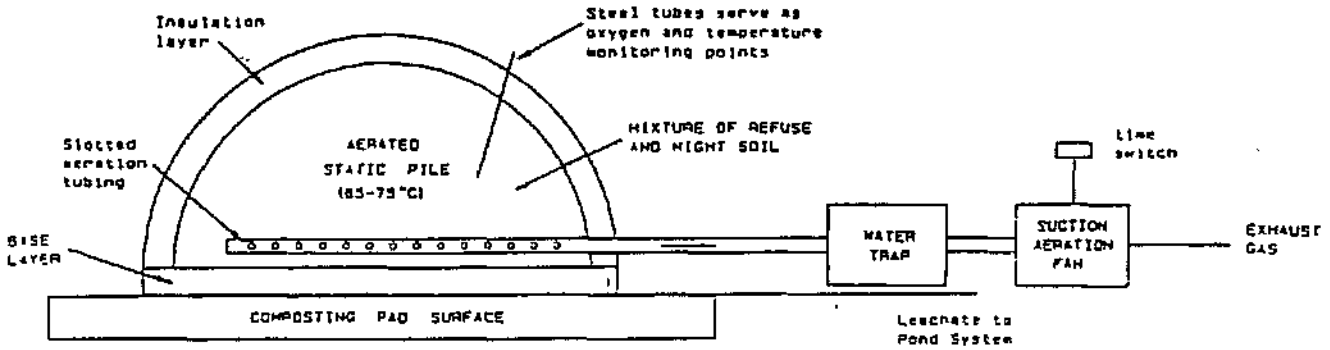

Figure 1: Equipment required for forced aeration composting of refuse and night soil.

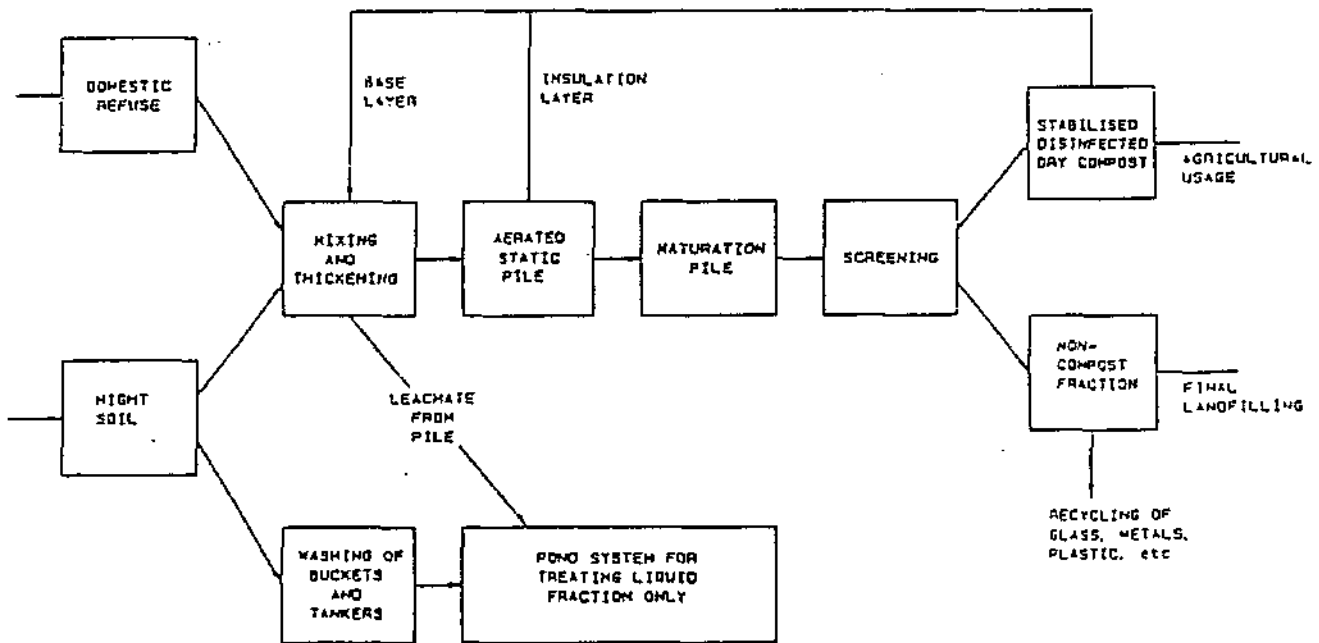

Figure 2: Unit operations of the forced aeration static pile Composting Of Refuse And Night Soil (CORANS) Process.

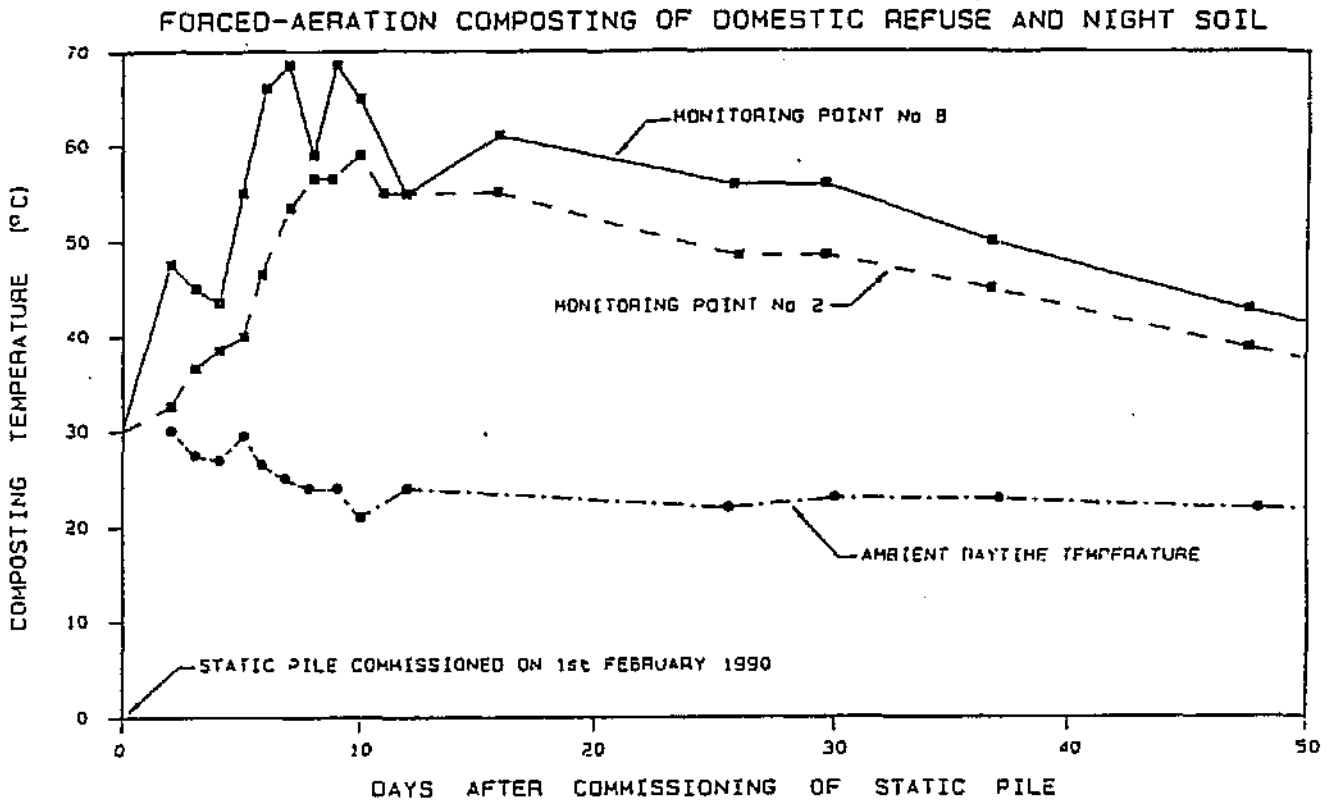

Figure 3: Typical temperature profile during prototype-scale CORANS composting experiments at Rini, Grahamstown.



*Paper for Presentation at the
65th Annual Conference
of the Water Environment Federation*

New Orleans, Louisiana
September 20-24, 1992

**FULL SCALE OPERATION OF FORCED AERATION
COMPOSTING GARBAGE AND NIGHT SOIL**

By

B.E. La Trobe

and

W.R. Ross

FULL SCALE OPERATION OF FORCED AERATION CO-COMPOSTING GARBAGE AND NIGHT SOIL

B E la Trobe, Waste Gas Engineering
74 Charles Street, Grahamstown 6140 South Africa

W R Ross, Ross Consultancy, Box 3483, Tygerpark 7536 South Africa

R A Rowswell, L.I.R.I. Technology, Grahamstown South Africa

ABSTRACT

In some geographic locations, where conventional treatment of sewage is not possible because of economic considerations, lack of infrastructure and technical skills or perhaps a chronic shortage of water, it is the intention of this paper to demonstrate that low cost sewage treatment is possible.

Stabilisation of the garbage and night soil was achieved by a process of forced aeration composting. Unsorted and unpulverised garbage was built into windrows (static piles), thickened night soil was then sprayed over the garbage. The completed windrows were covered with an insulating blanket of previously manufactured compost.

After a twenty-one day aeration period with temperature monitoring, the windrows were removed for sieving of the compost and reclamation of glass, cans and plastic etc. A stabilised pathogen free odourless compost is the final revenue bearing product, which is available in an accelerated manufacturing period.

KEY WORDS

Composting, Garbage, Night Soil, Windrows, Stabilisation, Profit.

INTRODUCTION

The results of the pilot study on Forced Aeration Composting of Garbage and Night Soil were delivered in a Paper at Toronto, Canada W.E.F. October '91 (LA Trobe & Ross 1990) - A full scale operation has now been established at the same site in Rini, Grahamstown, S.A.

The objective of the project is to demonstrate the feasibility of stabilising large quantities of the two important waste streams of garbage and night soil into an end product which does not have undesirable characteristics and has the capability of being revenue producing.

The supply of adequate sanitation systems in developing countries has deteriorated for many reasons. There is an urgent need for low cost appropriate sewage treatment technology. The need is particularly required in overpopulated outskirts urban areas where people are settling in search of work.

Sewage disposal in these areas is usually by means of a bucket system, as there is no infrastructural waterborne sewage systems and there is often a chronic shortage of water.

The night soil arising from these buckets is conventionally disposed of in lagoons.. These lagoons are often the cause of obnoxious odours and fly breeding. Garbage is often disposed of by uncontrolled landfilling which adversely impacts on the environment.

This paper describes the second phase operation of establishing a full scale plant to compost night soil with garbage as a bulking agent. The results show the process to be cost effective and environmentally acceptable. The process is registered under the Trade Name of "CORANS".

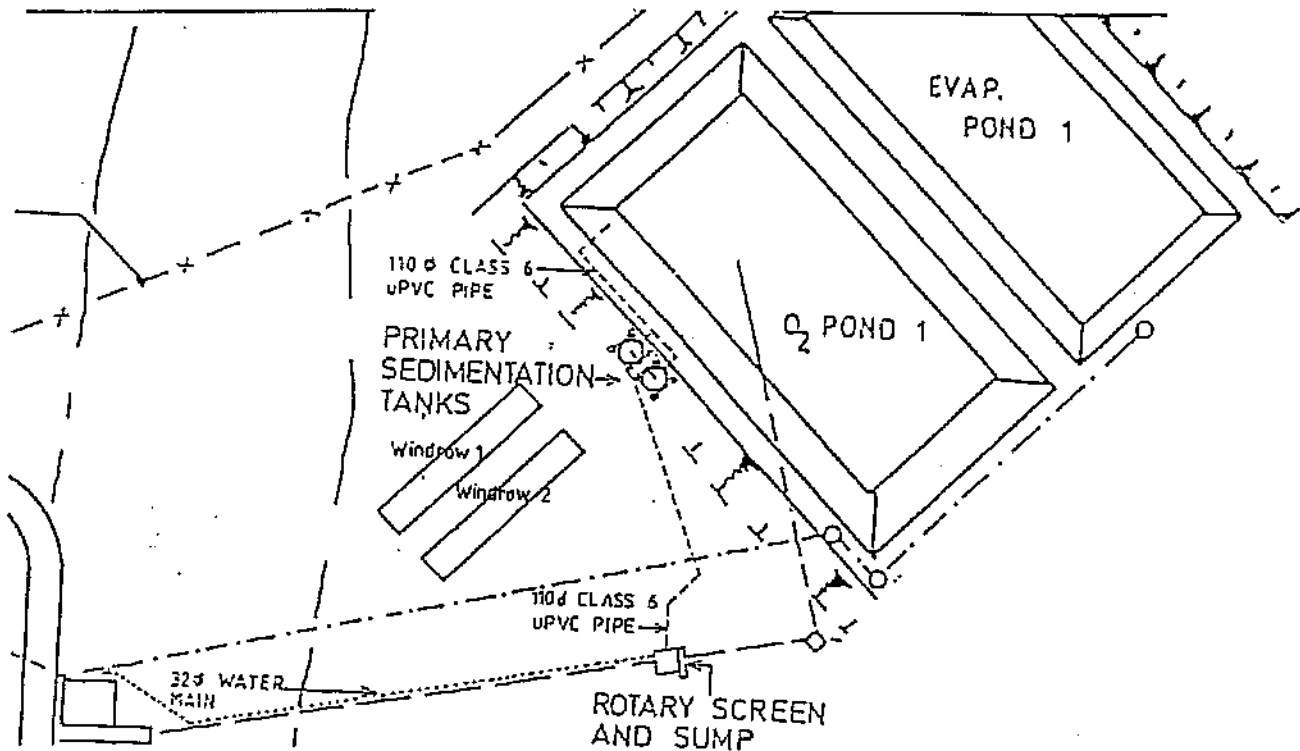

Figure 1 - Site Diagram of Rini Composting Garbage & Night Soil Plant

Figure 1 above is a site plan of the forced aeration composting plant with oxidation and evaporation ponds.

The night soil is delivered in tankers. It is allowed to flow into a sump by gravity and is filtered of large objects (bricks, stones, etc) prior to flowing into a water main which leads to a rotary screen and sump. Here the night soil is emascated and pumped in below ground piping (110 Class 6u P.V.C.) to overhead settling cone tanks. By means of flexible piping (50mm dia) the thickened night soil is spray distributed over layers of garbage.

The ground in the windrow areas was graded with slight gradient towards a central sump and drainage canal. The excess windrow leachate was pumped back to the rotary screen sump.

EQUIPMENT REQUIRED FOR THE COMPOSTING PROCESS.

* ROTARY SCREEN

A rotary screen fitted with high pressure water jet sprayers at a pressure of 4 bars. This breaks down

the solids to pass through the screen apertures of 12mm into a sump. The solids that defy breakdown are continuously passed out of the screen drum by means of a helical screw into a bin.

* SUMP

The sump is fitted with a submersible pump, which has a cutting mechanism to chop up solids into a fine state. The blended solids are then pumped to two sedimentation settling cones which are connected in parallel. The pump delivers the effluent to the cone tanks at a rate of 10-12 m³ per hour.

* SETTLING CONES

The capacity of these two vessels is 16,000 litres each (16 m³). The days discharge of night soil is allowed to settle and thicken overnight. The thickened liquor is withdrawn from the base of the cone where there is a shut off valve. The sludge is conveyed to the windrows areas for spraying onto the garbage by means of a flexible hose (50 mm dia). The supernatant overflow liquid from the settling cones discharges by gravitation via pipes to the nearby oxidation ponds.

* WINDROW BASES

The windrow bases in the pilot study were constructed concrete slabs. To reduce costs in the full scale plant the ground was merely graded with a slight slope. The drainage system has already been described.

* THE AERATION MANIFOLD PIPING

This consisted of three lengths of 110 mm piping of 6 metres each. The first two metres of the pipe was not perforated. The remainder of the pipe lengths were perforated with holes of varying diameter to ensure a uniform air suction along the length of the windrow. The remote pipe extremity was closed with a bung. All the perforations were bound with a layer of shade cloth to prevent solid access into the aeration pipe.

* RADIAL FAN/BLOWER

A radial Vane Fan Blower capable of a extraction rate of about 150 M³/ hr at 2900 R.P.M.

* A TIME SWITCH to regulate the flow of air through the windrows.

* A 200 litre WATER TRAP with 110 m.m. inlet and outlet. The trap was provided with a drain valve to release accumulated leachate and condensate.

* AN OXYGEN ANALYSER

* A DIGITAL THERMOMETER with an attached recording stem.

* A MANUALLY OPERATED SIEVE.

SOLID WASTE MATERIAL USED IN THE COMPOSTING EXPERIMENTS.

GARBAGE

Garbage is a complex conglomerate of organic and inorganic material. The organic component is normally between 55 to 60% which is sufficient to provide the energy for biological decomposition. The garbage acted as the bulking and filtering agent for the night soil solids. The garbage is not sorted or pulverised so as to utilise the porosity and structural strength created by metal cans and plastic containers etc; garbage is fairly dry (20% moisture). However as the moisture content of the night soil is in excess of 90% there is no problem. The moisture content at the start of the process should be about 65%. Excessive moisture obstructs the free flow of air through the windrow.

NIGHT SOIL

Night Soil consists of body wastes and paper. In its raw state it is highly putrescible and has a strong offensive odour.

GARDEN DEBRIS

Garden debris consisted of grass cuttings, leaves, small tree branches etc. All the material was processed through a chipping machine prior to delivery to the site.

EXPERIMENT PROCEDURES

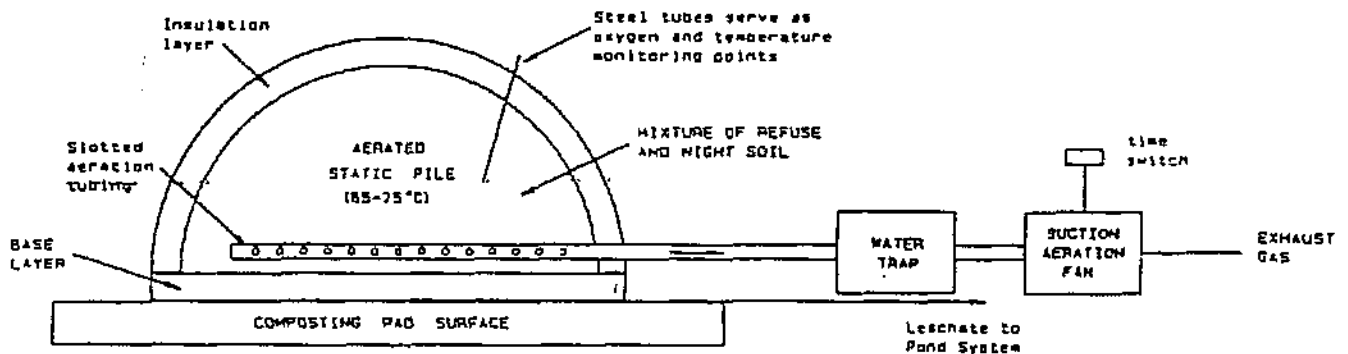

Figure 2 - Equipment required for forced aeration composting of garbage and night soil

- * A bed of 100mm thick dried stabilised sewage sludge was laid on the prepared windrow ground area, and shaped to a predetermined design (20m x 3m).
- * The perforated pipe as previously described was laid on the prepared bed, covered with shade cloth and connected to the water trap and fan blower. The two windrows shared a common interconnecting pipe but each windrow had its own shutoff valve.
- * The garbage was delivered to the site by truck and deposited on the prepared bed. The garbage was kept trimmed to the bed dimensions. Plastic bags containing garbage were slashed open and

large inert material was removed. The layer of garbage was covered with a layer of chipped garden debris. Thickened night soil from the settling cones was then sprayed over the layer at the rate of 200 litres per minute. This layering procedure was continued until the windrow height of 1.8 metres was reached. The sides of the windrows were sloped to about 50 degrees, giving a final windrow volume of about 100 cubic metres.

- * The windrow was covered with a 50 mm insulating blanket of stabilised sewage sludge.
- * The windrows were not subjected to any aeration until the internal temperature approached 40 degrees centigrade. When this had been achieved the initial aeration was continued full time for a twenty-four hour period then reduced to a flow of five minutes aeration followed by a fifty-five minute shut down.

The aim is to maintain a residual oxygen content of somewhere between 5 & 15%. In order to devitalise worm cysts and pathogenic bacteria an internal temperature of 55 degrees centigrade for a three day period is essential. This is the E.P.A. approved specification. (A Benedict, E. Epstein, A. Alpert 1988).

- * The composting period was 21 days with a further maturation period of 21 days prior to sieving.
- * Monitoring of internal windrow temperatures were carried out on a daily basis.

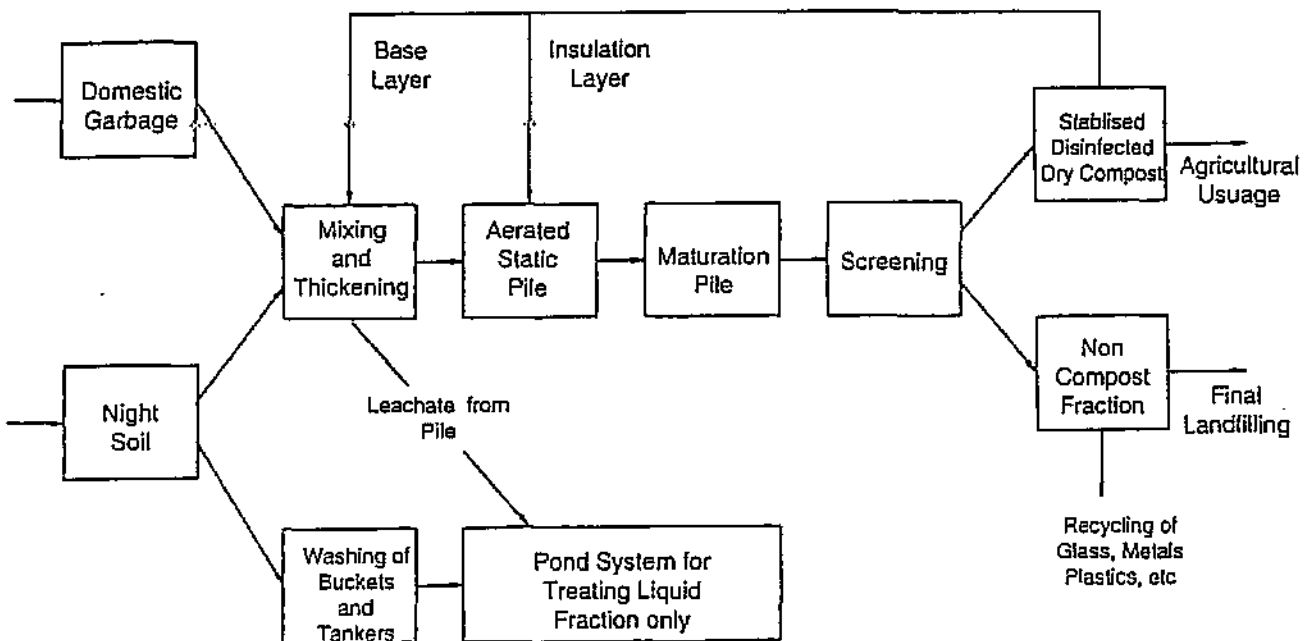

Figure 3 - Unit operations of the forced aeration static pile Composting of Garbage and Night Soil (CORANS) Process

Figure 3 - Process Flow Diagram

EXPERIMENTAL RESULTS

A typical temperature profile is shown in Figure 4. The significant difference between the ambient and internal temperature attained illustrates the bio-thermal activity of the micro-organisms and the potential energy of garbage and night soil.

RINI COMPOSTING GRAHAMSTOWN

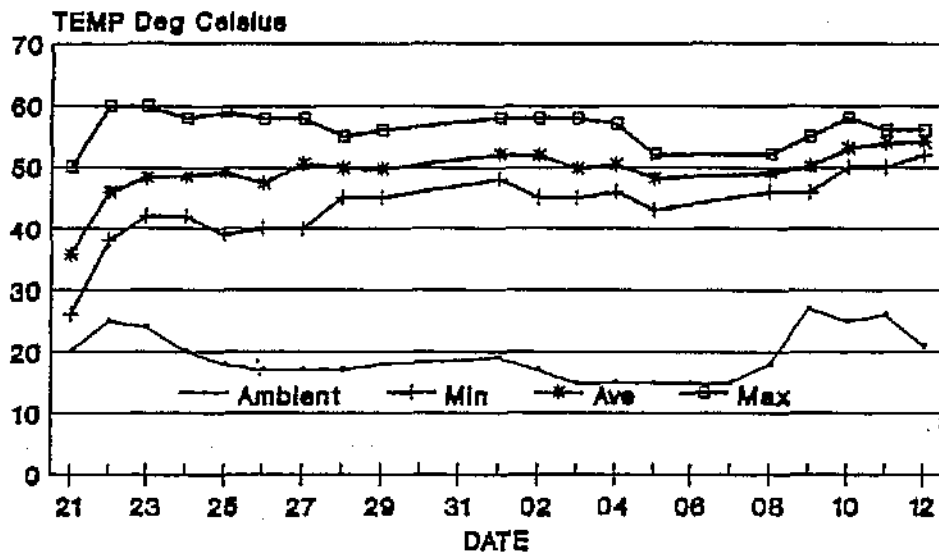

Windrow no.1 : 21 May - 12 June 1992

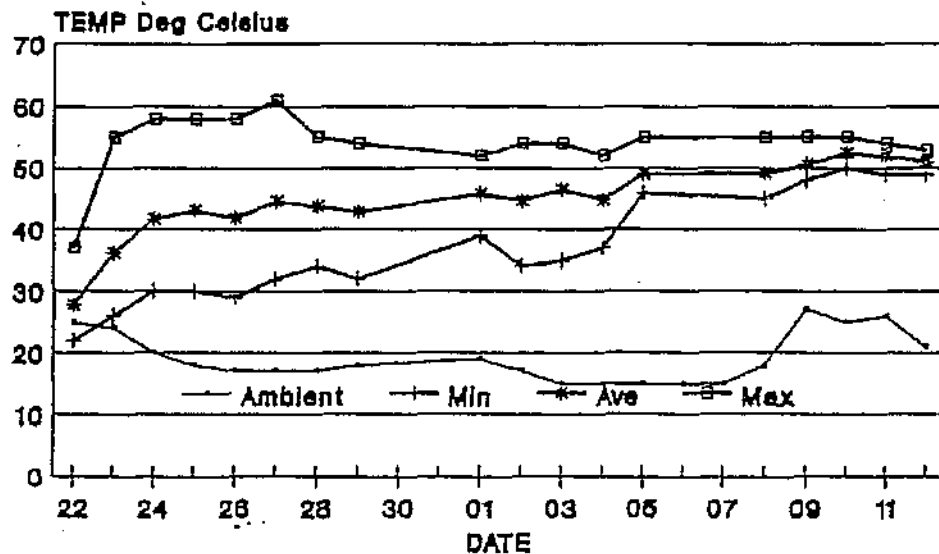

Windrow no.2 : 22 May - 12 June 1992

Figure 4.

The resultant compost will be sieved after a further period of twenty-one days maturation.

The results of the quality and yield per ton of garbage will reported at the Conference. However the pilot study demonstrated a compost yield of about 20% It is expected that this figure will be improved on in the full scale operation due to the addition of the garden debris.

The thickened night soil was gravitated over the garbage at the rate of 200 litres per minute. The solids content of the thickened night soil from the settling cones were as follows:

Total Solids %	4.57
Suspended Solids %	3.69
Organic Material %	3.75

GENERAL DISCUSSION

Disadvantages of the Corans System.

The filtering of the night soil through the garbage is a "messy procedure". However the full scale plant is a great improvement over the pilot study. The ability to distribute the thickened night soil from the settling cones to the windrows areas, and the windrows leachate drainage system has reduced this disadvantage considerably.

Advantages of the Corans Process.

- * The integrated composting of garbage and night soil in association with the pond system treats two major sources of polluted wastes generated by less developed communities. The system requires simple technology, equipment and unskilled labour.
- * The process reduces public health hazards because of the inactivation of pathogenic bacteria and worm cysts.
- * There is potential income from the sale of compost, as well as the recovery of plastic, cans and glass. The use of garbage as a bulking agent is less costly than wood chips etc.
- * There are no intrinsic limitations to the size of the plant. Use of the static pile method reduces the land requirement for the composting process.

CONCLUSION.

The experience obtained from the original pilot study and the installation of a full scale plant, which has only been in operation for a limited period; the results indicate that bio-thermal stabilisation of garbage and night soil by means of forced aeration is technically feasible. Installation of the full scale plant has not been without its problems. However nothing more than is usual with a new process.

The technique is particularly appropriate for less developed communities where simple, low cost, labour intensive technology is required.

ACKNOWLEDGMENT.

The Authors wish to thank The South African Water Research Commission, The Algoa Regional Service Council for financing the project, and the Rini Town Council for providing the facilities at their Waste Treatment Plant.

REFERENCES.

La Trobe, B.E. and Ross W.R. (1990) Forced Aeration Co-Composting of Domestic Refuse and Night Soil at Rini, Grahamstown. Contract Report to W.R.C. Pretoria S.A. 33P.

Nell, J.H. and Ross, W.R. (1987) Forced Aeration Composting of sewage sludge; Prototype Study, Contract Report to W.R.C. by the National Institute Water Research of the C.S.I.R. Pretoria, S.A. Report No. 101/1/87., 250P.

Benedict, A.H. Epstein, E Alpert J. Composting Municipal Sludges (1987) New Jersey, U.S.A.



SCREENING COMPOST FROM
REFUSE INERT MATERIAL.



MATURED COMPOST.



CONE SETTLING TANKS
FOR PRIMARY SLUDGE
AND MATURING WINDROWS



COMPOSTING PLANT TREATING NIGHT SOIL. DOMESTIC REFUSE (UNSORTED) IS USED AS A BULKING AGENT. WINDROW IN THE BACKGROUND 20m x 4m x 2m IS LAYERED. UNSORTED REFUSE SPRAYED WITH THICKENED NIGHT SOIL. SITE: RINI GRAHAMSTOWN.

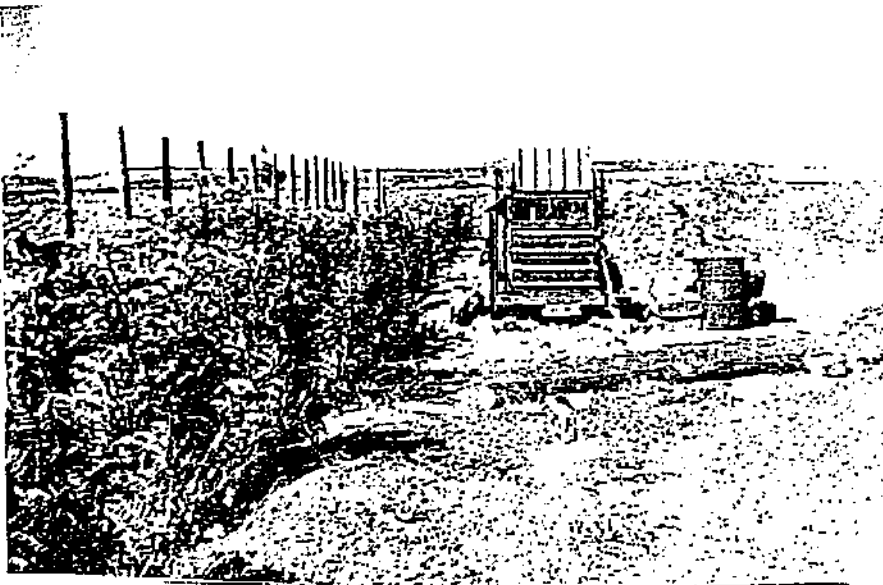

PLASTIC BAILER AND PEPPER TREES WHICH ARE IRRIGATED WITH LAGOON WATER.



WINDROW SPRAYING WITH PRIMARY EMASCERATED AND THICKENED SLUDGE.