

**INVESTIGATION INTO THE APPLICATION AND PERFORMANCE  
OF CONSTRUCTED WETLANDS  
FOR WASTEWATER TREATMENT IN SOUTH AFRICA**

by

**A WOOD**

**STEFFEN, ROBERTSON AND KIRSTEN CC (PTY) LTD**

Report to the Water Research Commission

WRC Report No 416/1/99  
ISBN 1 86845 515 7

## ACKNOWLEDGEMENTS

### Steering Committee:

Mr HC Chapman	Water Research Commission
Dr SA Mitchell	Water Research Commission
Mr AL Batchelor	CSIR
Mr D De Haas	Umgeni Water
Mr L Bredenhaan	DWA&F
Mr P Pybus	Stewart Scott Inc
Prof C Breen	Inst. Natural Resources
Mr D Huyser	Water Research Commission

### Additional Acknowledgements:

Mr G Borain	Umgeni Water
Mr D Human	Laubscher Human & Lombard CE
Mr PGJ Meiring	Wates Meiring and Barnard CE
Mr R Hoffman	Wates Meiring and Barnard CE
Mr D Cassel	Lethlabile Town Council
Mr D van der Spuy	Ninham Shand CE
Mr F Loubscher	Kruger National Park
Mr F Gerber	Kruger National Park
Cydna Laboratories	
Umgeni Water Laboratories	

The Water Research Commission (WRC) is acknowledged for the financial support provided for the investigation. The IAWQ Specialist Group on Macrophytes in Water Pollution Control are acknowledged for the willing provision of reports and information on the application and performance of Constructed Wetlands in water pollution control internationally.

# INVESTIGATION INTO THE APPLICATION AND PERFORMANCE OF CONSTRUCTED WETLANDS FOR WASTEWATER TREATMENT IN SOUTH AFRICA

## EXECUTIVE SUMMARY

There are approximately 70 Constructed Wetland systems in operation in South Africa, the greater number of which have been constructed for domestic wastewater treatment in small community applications. Constructed Wetlands are also being applied at several mining and industrial sites, as well as for stormwater and urban catchment management, riverine rehabilitation and protection, groundwater recharge and development of urban nature reserves and ecological sites.

The majority of operating Constructed Wetlands in South Africa appear to have been designed based upon reports on overseas systems, or simple rule-of-thumb assumptions. In many cases this approach has resulted in systems failing to meet design objectives which is seen as limiting the more widespread acceptability of the technology. To address this issue the Water Research Commission sponsored the project to Investigate the Application and Performance of Constructed Wetlands for Wastewater Treatment in South Africa.

The project identified a number of established Constructed Wetlands treating domestic wastewaters which were investigated in some detail. This was undertaken to (i) provide an overview of how the systems perform relative to their design objectives, to (ii) identify factors affecting the performance of alternative configurations and operational approaches, to (iii) assess opportunities for improving the relative performance of the different treatment approaches, and to (iv) provide general recommendations for the future implementation of the technology in South Africa.

The investigation has confirmed that there have been flaws in the design and operation of Constructed Wetlands for Wastewater Treatment in South Africa. This has largely been due to a general lack of understanding of the mechanisms and processes of wastewater treatment through a Constructed Wetland system. Despite the plants being perceived to be a primary treatment mechanism, their contribution is generally low, whereas the configuration and operating of the wetland is of significantly greater importance. The primary performance limitation is flow control through the system. Low permeability of the bed media tends to encourage surface flow rather than filtration through the bed for systems internationally designed for subsurface flow, and similarly, surface flow systems demonstrate significant short-circuiting. These factors minimise available residence times and contact opportunity for optimal treatment.

Despite less than optimal flow conditions and limited plant contributions to pollutant removal, the South African systems do demonstrate significant potential for wastewater treatment. Surface flow

systems receiving secondary sewage can achieve removals of COD and SS up to 20 g/m<sup>2</sup>/d, NH<sub>3</sub> and NO<sub>3</sub> removal up to 1.5 and 6.0 g/m<sup>2</sup>/d respectively, but limited pathogen removal of 99%, and low phosphate removal. Subsurface flow soil systems are severely limited by permeability, but where flow is maintainable for secondary wastewaters, COD, SS, NO<sub>3</sub> and PO<sub>4</sub> removal can be in excess of 85%, and pathogen removal of 10<sup>5</sup> fold, but NH<sub>3</sub> removal is low, <30%, due to poor oxygen transfer to the rootzone. Subsurface flow gravel beds can achieve high COD removal rates at loadings up to 100 g COD/m<sup>2</sup>/d with settled sewage, acting as anaerobic filters. Secondary units are then required to polish residual organic, nutrients and pathogens.

Engineering design to account for hydraulic limitations can provide a new generation of Constructed Wetlands better able to meet their treatment objectives. Surface flow systems, whether open bed or channel configuration, may be improved by provision of alternate shallow and deep water areas, and intermediate berms to assist flow and velocity buffering. Multiple species planting in defined areas through which the wastewater must flow assists contact opportunities for treatment by physical filtration, adsorption and absorption and biological treatment by attached microorganisms. Subsurface flow systems are limited by the permeability of the selected media. For horizontal flow systems these requires low width to length ratios and effective hydraulic gradients, or in a vertical mode, capacity to effectively distribute the water over the bed surface, and to collect the treated wastewater from subsurface drains over the full bed area. In each system configuration, performance may be improved by alternate feeding and draining to balance flow distribution and enhance aeration conditions within the beds, particularly for N removal.

In general there is a move to multiple unit systems which may include subsurface flow constructed wetland, surface flow marshes, ponds, grasslands and forest or shrub areas as required to meet the treatment and environmental conservation objectives. Mechanical units, such as biological trickling filters for ammonia removal, or recirculating sand filters for pathogen removal, may be required where land is restricted or treatment performance needs to be efficiently controlled.

In conclusion, Constructed Wetlands can provide a viable and effective form of wastewater treatment. A primary consideration is the need to control the hydraulics to optimise retention times and contact opportunities for effective treatment. Multiple units, and integrated systems, provide an opportunity to tailor the system to many treatment and ecological objectives.

Areas of the technology for which further research can be of benefit includes:

- \* Development of complete integrated Constructed Wetland wastewater treatment packages, including nutrient removal, for the full range of urban and rural communities.
- \* Development of models for the short and long-term processes by which nutrients, organic and metals can be immobilised and/or transformed during passage through the Wetland systems under different operational and maintenance programmes
- \* Establishment of appropriate species diversity for single and integrated Wetland systems (i.e. not a *Fragmites* or *Typha Sp* monoculture)
- \* Identification and development of uses and viable markets for Wetland products
- \* Expansion of the concepts developed for domestic wastewater treatment to the wider field of environmental protection, pollution control and conservation.

## CONTENTS

SECTION & DESCRIPTION	PAGE
1 INTRODUCTION AND SCOPE .....	1
2 DEVELOPMENT OF CONSTRUCTED WETLAND TECHNOLOGY IN S.A. ...	2
3 APPLICATION OF CONSTRUCTED WETLANDS .....	3
4 CONSTRUCTED WETLAND TECHNOLOGICAL APPROACHES .....	4
4.1 Conventional Configurations: Surface Flow and Subsurface Flow .....	4
4.2 Integrated Systems .....	6
5. ADVANTAGES AND CONSTRAINTS OF CONSTRUCTED WETLANDS .....	13
6. SOUTH AFRICAN CONSTRUCTED WETLAND SYSTEMS .....	15
6.1 Mpophomeni .....	15
6.2 Letlhabile .....	15
6.3 Ladybrand .....	15
6.4 Bethlehem .....	15
6.5 Kruger National Park .....	16
6.6 Pilanesburg Game Reserve .....	16
6.7 Pietersburg Truck Stop .....	16
6.8 Klipdrift .....	16
6.9 Middelburg .....	16
6.10 Reddersburg .....	17
6.11 Kranskop .....	17
6.12 Friemansheim .....	17
6.13 Warmbaths Cotton Gin .....	17
6.14 Karbochem Newcastle .....	17
6.15 Midrand Residential Home .....	18
6.16 Mount Grace Hotel .....	18
6.17 CSIR Campus Wetland .....	18
6.18 Potchefstroom .....	18
6.19 Makwane .....	19
6.20 Umzimkulu Sugar Mill .....	19
6.21 Felixston Sugar Mill .....	19

6.22	Milnerton .....	19
6.23	Oil Industry Wetlands .....	19
6.24	Bannockburn Minewater .....	20
6.25	Van Dykes Drift Mine .....	20
6.26	Atlantis Groundwater Recharge Wetland .....	20
6.27	Sandton Urban Wetlands .....	20
<b>7.</b>	<b>PERFORMANCE REVIEW OF SELECTED CONSTRUCTED WETLAND SYSTEMS</b>	
	.....	<b>21</b>
7.1	Mpophomeni .....	21
	7.1.1 System Configuration .....	21
	7.1.2 Wastewater Treatment Performance .....	21
	7.1.3 Hydraulic Characteristics .....	26
	7.1.4 Phosphate Partitioning .....	27
	7.1.5 Pilot Studies .....	27
	7.1.6 Vegetation Development .....	28
	7.1.7 Management .....	28
	7.1.8 Management Recommendations .....	29
7.2	Letlhabile .....	29
	7.2.1 System Configuration .....	29
	7.2.2 Wastewater Treatment Performance .....	30
	7.2.3 Hydraulic Characteristics .....	32
	7.2.4 Solids Accumulation .....	32
	7.2.5 Vegetation Development .....	33
	7.2.6 Management .....	33
	7.2.7 Management Recommendations .....	34
7.3	Ladybrand .....	35
	7.3.1 System Configuration .....	35
	7.3.2 Wastewater Treatment Performance .....	35
	7.3.3 Hydraulic Characteristics .....	39
	7.3.4 Surface Solids Accumulation .....	40
	7.3.5 Vegetation Development .....	40
	7.3.6 Management .....	41
	7.3.7 Management Recommendations .....	42

7.4	Bethlehem .....	43
7.4.1	System Configuration .....	43
7.4.2	Wastewater Treatment Performance .....	43
7.4.3	Hydraulic Characteristics .....	48
7.4.4	Surface Solids Accumulation .....	49
7.4.5	Vegetation Development .....	49
7.4.6	Management .....	50
7.4.7	Management Recommendations .....	50
7.5	Kruger National Park .....	51
7.5.1	System Configuration .....	51
7.5.2	Wastewater Treatment Performance .....	52
7.5.3	Crocodile Bridge Wetland System .....	53
7.5.4	Hydraulic Characteristics .....	53
7.5.5	Vegetation Development .....	54
7.5.6	Management .....	54
7.5.7	Management Recommendations .....	55
8.	<b>DISCUSSION OF SOUTH AFRICAN EXPERIENCES .....</b>	<b>56</b>
9.	<b>GUIDELINES FOR THE IMPLEMENTATION OF CONSTRUCTED WETLANDS .....</b>	<b>58</b>
9.1	Primary Wastewater Treatment .....	58
9.2	Maximum Loading .....	58
9.3	Bed Depth and Media .....	58
9.4	Inlet Distribution .....	58
9.5	Terracing .....	59
9.6	Parallel Cells .....	59
9.7	Vertical Flow .....	59
9.8	Secondary Wastewater Treatment .....	59
9.9	Secondary Organic Loading .....	60
9.10	Tertiary Wastewater Treatment .....	60
9.11	Hydraulic Control .....	60
9.12	Plants .....	61
9.13	System Monitoring .....	62
10	<b>CHALLENGES/FUTURE RESEARCH OPPORTUNITIES .....</b>	<b>62</b>



## APPENDIX

SECTION AND DESCRIPTION	PAGE
<b>A. WASTEWATER POLLUTANT REMOVAL MECHANISMS</b> .....	<b>64</b>
A.1 Treatment Performance of Wetland Systems .....	64
A.2 Organic Load COD/BOD .....	66
A.3 Suspended solids .....	66
A.4 Phosphate .....	67
A.5 Nitrogen .....	68
A.6 Pathogen Removal .....	69
<b>B. ROLE OF THE PLANTS AND BED MEDIA IN WASTEWATER TREATMENT</b>	<b>70</b>
B.1 Contribution of the Wetland Plants To Wastewater Treatment .....	70
B.2 Contribution of the Bed Media to Wastewater Treatment .....	71
B.3 Stability of Constructed Wetland System in Wastewater Treatment .....	71
<b>C. CONSTRUCTED WETLAND DESIGNED MODELS</b> .....	<b>72</b>
<b>D. DESIGN GUIDELINES</b> .....	<b>76</b>
D.1 Siting .....	76
D.2 Layout .....	76
D.3 Organic Loading .....	76
D.4 Hydraulic Loading .....	77
D.5 Detention Time .....	77
D.6 Evapotranspiration/Infiltration .....	78
D.7 Pretreatment .....	78
D.8 Aspect Ratio .....	78
D.9 Water Depth in Free Water Systems .....	79
D.10 Subsurface Flow System Bed Depth .....	79
D.11 Media for Subsurface Flow Systems .....	79
D.12 Inlet Arrangement .....	80
D.13 Bed Slope .....	81

<b>SECTION AND DESCRIPTION</b>	<b>PAGE</b>
D.14 Outlet Control .....	81
D.15 Plants .....	81
D.16 Planting .....	82
D.17 Construction .....	82
D.18 Operation .....	83
D.19 Management Opportunities .....	86
D.19.1 Management Aspects .....	86
D.19.2 Monitoring .....	86
D.19.3 Process Performance and Control .....	87
D.19.4 Fate of Specific Constituents .....	87
D.19.5 Development of Database .....	88
D.20 Cost of Constructed Wetland Treatment Systems .....	88
<b>BIBLIOGRAPHY .....</b>	<b>93</b>

## TABLES

SECTION AND DESCRIPTION	PAGE
<b>Table 1</b> Application of Constructed Wetlands Internationally .....	3
<b>Table 2</b> South African Application of Constructed Wetlands .....	4
<b>Table 3</b> Process Criteria for Constructed Wetlands .....	5
<b>Table 4</b> Performance of the Pilot Integrated Wetlands/Trickling Filter .....	7
<b>Table 5</b> COD Removal Performance of 3 Stage Integrated Wetland System .....	8
<b>Table 6</b> Treatment Performance of Chinese Integrated Wetland System .....	8
<b>Table 7</b> Southern African Constructed Wetland Systems .....	14
<b>Table 8</b> Wastewater Treatment Performance of Mpophomeni Constructed Wetland ..... (Initial 5 year period)	24
<b>Table 9</b> Wastewater Treatment Performance of Mpophomeni Constructed Wetland ..... (Indicating quality of overflow and underflow)	24
<b>Table 10</b> Mpophomeni Constructed Wetland Treatment Performance as Illustrated by a 48 hr Composite Sampling Exercise .....	25
<b>Table 11</b> Particle Size, Distribution Root and Organic Matter Content at Different Depths of Mpophomeni Constructed Wetland .....	26
<b>Table 12</b> Distribution and Partitioning of Phosphorous in Mpophomeni Constructed Wetland .....	27

<b>Table 13</b>	Treatment Performance Of Letlhabile Constructed Wetland System Over 2 year Period .....	30
<b>Table 14</b>	Treatment Performance of Letlhabile Constructed Wetland System Medium Influent NH <sub>3</sub> -N (mg/l) .....	31
<b>Table 15</b>	Treatment Performance of Letlhabile Constructed Wetland High Influent NH <sub>3</sub> -N (mg/l) .....	31
<b>Table 16</b>	Performance of Ladybrand Constructed Wetland System .....	38
<b>Table 17</b>	Spot Sampling of Individual Wetland Cell Outlet Points of Ladybrand Constructed Wetland System .....	38
<b>Table 18</b>	Microbiological Quality of Individual Wetland Cell Outline of Ladybrand Constructed Wetland System .....	38
<b>Table 19</b>	Performance of Bethlehem Wetland System (combined effluent from beds 1-5) ..	44
<b>Table 20</b>	Bethlehem Constructed Wetland Outlet PO <sub>4</sub> -P and Flow Volume Compared to Inflow PO <sub>4</sub> -P .....	47
<b>Table 21</b>	Microbiological Analysis of Bethlehem Constructed Wetland System .....	47
<b>Table 22</b>	Performance of 3 Kruger Park Constructed Wetland Systems Receiving Septic Tank Effluent .....	53
<b>Table 23</b>	Challenges for Future Development of Constructed Wetlands for Wastewater Treatment and Pollution Control .....	62

A1	Regression Analysis of FWS Constructed Wetland Systems Performance .....	64
A2	Treatment Performance of USA Constructed Wetland Systems .....	64
A3	Treatment Performance of Dutch Surface Flow Constructed Wetland Systems ...	65
A4	Treatment of European Subsurface Flow Constructed Wetland Systems .....	65
A5	Treatment Performance of Vertical Flow Constructed Wetland Systems .....	65
A6	Treatment Performance of Gavel Bed Hydroponic Horizontal Flow Constructed Wetland System .....	65
B1	Uptake of N and P by Three Common Wetland Species .....	71
C1	Hydraulic Conductivity and Reaction Rates for Subsurface Flow Media Types ...	74
D1	Soil Physical Characteristics .....	80
D2	Unpredictable System Disturbances for Constructed Wetlands Treating Wastewaters .....	84
D3	Predictable System Disturbances for Constructed Wetlands Treating Wastewaters	85
D4	Operational Issue - mosquito control .....	87
D5	Operational Issue - vegetation control .....	87
D6	Monitoring Parameters for Constructed Wetland Systems .....	89
D7	Relative Comparison of Cost, Operation and Treatment for Various Constructed Wetland System Configurations .....	90
D8	Sub-Surface Flow Wetland - Construction Costs .....	91
D9	Surface Flow Wetland - Construction Costs .....	92

## FIGURES

## PAGE

<b>Figure 1</b>	Cutaway perspective of a Constructed Wetland System .....	9
<b>Figure 2</b>	Details of reed and crop beds at Abu Attwa Ismailia, Egypt .....	10
<b>Figure 3</b>	Cresset House Constructed Wetland System, Plan View .....	11
<b>Figure 4</b>	Cresset House Constructed Wetland System, Side View .....	11
<b>Figure 5</b>	Decision Support Tree for Constructed Wetland Treatment System Options .....	12
<b>Figure 6</b>	Mpophomeni Constructed Wetland Plan and Cross Section .....	23
<b>Figure 7</b>	Lethabile Sewage Treatment and Constructed Wetland System .....	36
<b>Figure 8</b>	Ladybrand Sewage Treatment and Constructed Wetland System Schematic .....	37
<b>Figure 9</b>	Ladybrand Constructed Wetland Cross-Section .....	45
<b>Figure 10</b>	Bethlehem Constructed Wetland System .....	46

# INVESTIGATION INTO THE APPLICATION AND PERFORMANCE OF CONSTRUCTED WETLANDS IN WASTEWATER TREATMENT IN SOUTH AFRICA

## 1 INTRODUCTION AND SCOPE

Constructed Wetlands in wastewater treatment and pollution control have now been in operation internationally for over 40 years with several thousand systems in operation around the world, and similarly several thousand articles in scientific and popular press on the subject (Kadlec 1994). These generally demonstrate that Constructed Wetlands can form an effective and adaptable treatment option with potential to receive almost any contaminated water that is treatable by biological and physico-chemical means.

Despite the acknowledged successes of the technology, the inability of many systems to perform as efficiently as intended can largely be related to a lack of understanding of the mechanisms by which Constructed Wetland systems actually function, and how these may be best managed to meet a specific treatment objective (Wood 1994).

There are approximately 70 operating Constructed Wetlands in South Africa. These are predominantly for the treatment of domestic wastewater where the approach has found an acceptance in the treatment of sewage from small communities, and particularly for the accommodation facilities in the National Parks, especially the Kruger National Park. Variations of the technology are also utilised for polishing of oxidation pond effluents and conventional secondary treated wastewaters to meet specific final effluent quality objectives. Further applications include several industrial and agricultural effluents, contaminated minewaters and stormwater runoffs, groundwater recharge, riverine protection and for the environmental enhancement of urban catchments.

Although there are a number of operating Constructed Wetlands in South Africa there has been little performance data generally available to assist in the development of design and operational guidelines suitable to the South African wastewater characteristics, climate and treatment objectives. The majority of the installed systems appear to have been designed based upon reports on overseas systems, or simple rule-of-thumb assumptions.

The Water Research Commission (WRC) sponsored investigation was intended to review international application and performance information on the technologies and relate the international experiences to what has, and is being established in South Africa. It was also intended to review how these systems are designed, operated and perform, and what lessons can be learnt for the further development and improvement of design and operational practices to improve treatment efficiency and reliability for future systems.

## 2 DEVELOPMENT OF THE CONSTRUCTED WETLAND TECHNOLOGY IN SOUTH AFRICA

The application of Constructed Wetlands in wastewater treatment in South Africa was initially stimulated by the need to remove residual nutrients from secondary treated domestic and industrial effluents. Surface flow Constructed Wetland channels established at Giyani, NkowaKowa, Letlhabile and Newcastle in the early, to mid, 1980's provided a relatively simple means of polishing the wastewaters after more conventional secondary treatment. There appears to have been little published design criteria for such systems for nutrient polishing, and their application was an innovative development of the conventional maturation pond systems.

During this period the Constructed Wetland technology in Europe was tending to develop systems based on filtration of the wastewater through a porous media (soil or gravel) in which the aquatic plants were established (Alexander 1986). The flow of wastewater in a subsurface flow mode resembling an expanded French drain or a horizontal trickling filter, rather than ponded surface flow approach of the local channels.

The construction of the Mpophomeni Constructed Wetland in KwaZulu Natal in 1985, to remove phosphorus from Biological Trickling Filter effluent, represents the first serious attempt in South Africa to adapt the application of subsurface flow Constructed Wetland systems. Specific consideration was given to the design and operation of the system to ensure the effluent passes through the specially selected iron rich soil media with the intention for phosphate to be immobilised in the soil as the effluent passed through the Wetland.

Whilst several full-scale systems were being implemented in the early 1980's, local research of the development of the technology was only in its infancy. The University of Orange Free State were investigating the polishing of oxidation pond waters through sand and gravel subsurface flow systems (Wrigley 1988). The University of Witwatersrand produced a comprehensive review entitled 'Wetlands in Municipal Wastewater Treatment' (Rogers 1985), and subsequently established a Constructed Wetland pilot plant at Johannesburg's Olifantsvlei sewage works where the ability of nominally natural Wetland configurations were studied for nutrient and pathogen removal potential. The units were also used to assess floating and submerged Wetland systems, and the development of plant communities in response to inundation with secondary effluents (Rogers 1990).

Research at the Council for Scientific and Industrial Research (CSIR) in Pretoria from 1985 has investigated the importance of the roles of the primary components of the Wetland system:

- (i) media: soil, gravel, gold slimes, power station and coal ash and combinations thereof;
- (ii) plants: kikuyu grass, sedges, rushes, reeds and tall grasses;
- (iii) wastewater type: screened primary domestic sewage, effluents from anaerobic and oxidation ponds, biofilter and activated sludge systems, industrial cooling water, petrochemical and septic tank effluent. Research has also pursued integrated Wetland units (surface and subsurface flow) with high rate algal ponds, oxidation ponds, meadows (overland flow),



nitrification columns and low rate anaerobic sludge blanket and anaerobic contact reactors. (Wood 1988, 1990; 1991; Batchelor 1990, 1994, 1996).

Witwatersrand University has undertaken student projects investigating the role of Wetlands in acid mine drainage treatment (Fourie 1994), and the Rand Afrikaans University has investigated the accumulation of heavy metals from mining and runoff waters in Wetland systems (De Wet 1990; Van der Merwe 1990). The University of Potchefstroom has investigated the ability of a Constructed Wetland system to polish secondary activated sludge effluent from an explosives factory, and the microbiology associated with the system (van der Walt 1995), whilst the Universities of Natal and Cape Town and Port Elizabeth, amongst others, and a number of colleges and schools have had various projects investigating the potential of Wetland systems in water pollution control.

There has, and is, therefore significant academic and practical interest in Constructed Wetlands as a technology for wastewater treatment in South Africa.

### 3 APPLICATION OF CONSTRUCTED WETLANDS IN SOUTH AFRICA

Most Constructed Wetlands have been built to provide advanced or tertiary treatment of municipal wastewaters, but the range of applications is swiftly expanding. In particular, the treatment of animal wastes, agricultural runoff and industrial effluents are good potential candidates for this technology. Often, ancillary benefits are designed into, and realized from, Wetlands constructed for treatment. Bird and other aquatic wildlife usage is generally higher in treatment Wetlands than in adjacent natural Wetlands, because the treatment Wetland is typically more eutrophic and hence more productive of food and habitat (Kadlec 1994).

Internationally Constructed Wetlands have found application in a wide variety of uses, as illustrated by Kadlec (1994):

**Table 1. Application of Constructed Wetlands Internationally (after Kadec 1994)**

Application	Scope
Municipal Wastewater Treatment	Advanced Secondary - Post Tertiary Single families to 200 000 persons
Mine Drainage	Coal, Base & Precious Metals
Urban Stormwater	In Conjunction with Detention Ponds
Rivers, Lakes & Reservoirs	In-line & Recycle
Agricultural Runoff	Field Scale to Watershed Scale
Livestock Wastewater	Feedlots, Dairies, Piggeries
Industrial	
Food Processing	Potato, Sugar, Seafood, Abattoir, Brewery
Petroleum	Product Water, Refinery Effluent
Chemical	Pulp & Paper, Textiles,
Landfill Leachate	Municipal Landfills, Remediation
Sludge Drying	Municipal & Industrial

In South Africa almost all of the potential applications of the above list are being utilised or at least considered:

**Table 2. South African Application of Constructed Wetlands**

Application	Scope
Domestic Wastewater Treatment	Advanced Secondary - Post Tertiary Single families to 20 000 persons Hotels, Hospitals and Recreation camps
Mine Drainage	Coal, Base & Precious Metals
Urban Stormwater	In Conjunction with Detention Ponds
Rivers, Lakes & Reservoirs	In-line
Agricultural Runoff	Dam edge stabilisation and ecosystem enhancement
Livestock Wastewater	Feedlots and Trout farms
Industrial	
Food Processing	Sugar, Abattoir, Soft Drink, Brewery, Potato
Petroleum	Product Water, Refinery Effluent
Chemical	Pulp & Paper, Explosives, Fertilizers
Wastesite Leachate	Site Remediation

#### 4 CONSTRUCTED WETLAND TECHNOLOGICAL APPROACHES

##### 4.1 Conventional Configurations: Surface Flow and Subsurface Flow

Constructed Wetlands aim to systematically control and optimise the ability of a Wetland system to remove or transform wastewater pollutants, and in many cases to also create an aesthetic environment for the development of wildlife and social objectives.

There are two basic concepts being implemented worldwide, based primarily around whether the individual cells are operated as a surface flow or a subsurface flow system:

**Free Water Surface (FWS)** systems mimic natural systems in that water flows over the bed of the Wetlands as a shallow water pond and is filtered through the dense stand of aquatic plants;

**Subsurface Flow (SF)** systems promote water flow in a horizontal or vertical flow path through a shallow, permeable, media in which the plants are established. Treated effluent is collected in an underdrain for discharge.

Free Water Surface (FWS) systems are popular in the United States, particularly for large wastewater flows and polishing of nutrients, whilst Subsurface Flow (SF) systems are widely accepted throughout Europe, Australia and South Africa (Wood 1991).

No general consensus exists on the overall advantages of the FWS versus SF Constructed Wetland systems, since each application is very much site specific and largely dependent upon land availability, and construction costs and treatment objectives.

Advantages of the FWS are generally lower installation cost and potentially simpler hydraulics.

Advantages of the SF Wetlands are minimisation of vector and odour problems, and possibly greater assimilation potential per unit area of land in terms of organic and nutrients, particularly where winter temperatures are low (Reed 1993). However, the provision of a suitably permeable media tends to be the most expensive component of the SF systems, and the factor responsible for the majority of treatment problems when permeability is not adequately catered for (Crites 1992).

Table 3 illustrates process criteria for Free Water Surface (FWS) and Subsurface Flow (SF) Constructed Wetlands (adapted from Reed (1992) and Knight (1992))

**Table 3 Process Criteria for Constructed Wetlands**

Factor	Typical FWS	Typical SF
Detention time, d	5 - 14	2 - 7
Max BOD loading rate, kg/ha.d	80	75
Water or Media Depth, m	0.1 - 0.5	0.10 - 1.0
Hydraulic loading rate, mm/d	7 - 60	2 - 30
Aspect Ratio l to w	2:1 to 10:1	0.25:1 to 5:1
Mosquito Control	Required	Not required
Harvest Frequency, yr	3 - 5	3 - 5

N.B. It should be recognised that areal requirements relate to the variations in wastewaters that the systems are generally designed to receive. The FSW systems are usually receiving pretreated or secondary wastewaters while the SF systems often receive primary wastewaters. The SF systems are also often a component of an integrated system where the discharge from the SF system passes to a FWS for polishing.

The earlier European design basis for soil media SF systems recommended an areal equivalent of 2 m<sup>2</sup>/person equivalent (p.e.) (Kickuth 1984), but this was subsequently raised to 5m<sup>2</sup> to account for permeability limitations found with higher loading rates to soil based systems, and the tendency to short-circuit by surface rather than subsurface flow (Cooper 1990).

In further developing the SF concept in Europe, systems have tended to move towards gravel beds to maintain hydraulic control, with >100 systems applied in the UK. A Constructed

Wetland designed upon a basis of 3 m<sup>2</sup>/p.e. and 53 mm/m<sup>2</sup>/d achieved effluent qualities of BOD <5 mg/l, SS <30, AmmN < 15 mg/l at an average Hydraulic Retention Time (HRT) of only 7 hours Green (1993)

The Gravel Bed Hydroponic (GBH) system developed by the University of Portsmouth is also proving successful for small community installations. The GBH is a narrow, long (up to <100 m), sloping (0.5 - 1%), shallow, gravel beds planted with reeds. Where sewage has been fed at a continuous rate of 20l/minute for some 15 hour each day (90mm/m<sup>2</sup>.d), the bed being allowed to rest during the night, the treatment showed high elimination rates of SS 79 %; BOD 79; NH<sub>3</sub> 85%; Total coliform 98 faecal coliform 97%. It was also found that as the organic load is removed in the upper sections of the channel the dissolved oxygen concentrations increase down the bed, nitrification activity increases to allow combined organic and nitrogen removal through the channel (Loveridge 1993; Bahgat 1994).

Vertical flow systems are also seen as suitable for achieving effluents which have oxidised ammonia to nitrate as well as BOD removal. Cooper (1994) recommends vertical flow systems be based upon 1 m<sup>2</sup>/p.e when treating settled sewage for BOD removal only and 2 m<sup>2</sup>/p.e for BOD removal followed by separate phase nitrification. The total area is split into at least 2 stages to accomplish re-aeration by re-distribution of flows between units. The two stages of the vertical flow total surface area may be divided between a number of individual cells at each stage. These cells are operated sequentially, usually allowing each bed to be loaded 1/week.

Haberl (1994) reports upon the development of vertical flow, intermittently operated systems in Austria. Treating domestic sewage based upon 5 m<sup>2</sup>/p.e and a 6 hour loading interval (30 - 40 mm/d) the treatment efficiency achieved has been highly effective and despite the Austrian temperate climate nitrification was not unduly affected by winter temperature conditions. NH<sub>3</sub>-N 94%; TN 36%; TP 63% and COD 90%. Urbanc-Bercic (1994) has also reported upon Czechoslovakian system performance of integrated, intermittently loaded vertical and continuously loaded horizontal Wetland systems for small domestic sewage treatment. Alternate vertical beds and a horizontal bed at 30 mm/d with gravel and sand media achieved contaminant removal of NH<sub>3</sub>-N 97%; NO<sub>3</sub>-N 74%; Org-N 85%; TP 97%; COD 94%.

## 4.2 Integrated Systems

The Constructed Wetland system itself is increasingly unlikely to be a single unit but rather an integration of units, which may include Constructed Wetlands, Marshes, Ponds, Grasslands and even Forest/Shrub areas. The individual units making up the complete Constructed Wetland system may then operate as surface or subsurface filtration systems, as appropriate to optimise physico-chemical pollutant removal mechanisms and to balance aerobic and anaerobic biological degradation reactions, evapotranspiration and infiltration.

Requirements to meet low residual nutrient levels, led to the development of the integrated Wetlands, such as the Marsh-Pond-Meadow (M-P-M) systems (Conway 1988). In the M-P-M

option the Marsh may be a sand or gravel media SF unit designed to provide removal of organic after primary and possibly secondary treatment. The Facultative Pond, with its inherent population of floating and submerged plants, eg algae, *Elodea* and *Potamogeton*, provides buffering capacity and oxygenation of the water for nitrification and pathogen destruction. The grass planted Meadow provides final sedimentation and filtration of suspended solids, organic and nitrate removal through denitrification, and further pathogen destruction. Conway (1988) reported that whilst a single SF system receiving secondary treated domestic wastewater at 50 mm/d would not be expected to achieve > 50% NH<sub>3</sub> removal due to oxygen limitations, a M-P-M may achieve > 75 % NH<sub>4</sub> and > 80 % PO<sub>4</sub> reduction, at an equivalent loading.

An approach developed in South Africa by Batchelor (1994) to optimise nutrient removal, provides for organic removal via a highly loaded Constructed Wetland (up to 100g COD/m<sup>2</sup>/d) prior to transfer to a Biological Filter for nitrification, and finally to a polishing Wetland FWS stage for nitrate removal. Opportunity to recycle between individual cells is provided to assist in denitrification and alkalinity control of nitrification induced wastewater pH depression. The combined anaerobic primary Wetland, Biofilter and FWS meadow Wetland is able to achieve COD reduction from 400 mg/l to < 40 mg/l and ammonia reduction from 32 mg/l to < 2 mg/l, with residual nitrate at < 5 mg/l at a hydraulic loading of up to 350 mm/d to the primary Wetland, and 125 mm to the FWS units. Table 4 illustrates the COD and ammonia removal efficiency of the South African developed integrated Wetland Biofilter configuration at the hydraulic loading of 200 mm/d to the primary bed and 100 mm/d to the secondary bed.

An alternative to primary anaerobic Wetlands, is to incorporate an Anaerobic Pond operated in an upflow anaerobic sludge blanket (UASB) mode with a hydraulic detention time of the order of 24 hrs. The primary treated wastewater feeds to two-stage FWS Wetlands which may involve drawing a recycle stream from the second Wetland, aerating by cascade or mechanically and returning it either to the secondary or primary Wetland bed. Table 5 illustrates the reduction in COD and ammonia concentrations between the individual components of such a system. The surface flow Wetland cells are receiving a loading of approximately 100 t/m<sup>2</sup>/d (Batchelor 1994).

**Table 4: Performance of the Pilot Integrated Wetlands/Trickling Filter (Application Rate 200 t/m<sup>2</sup>/d)**

Effluent Source	Concentration mg/l	
	COD	NH <sub>3</sub>
Influent Settled Sewage	413	35
Primary Wetland Effluent	107	24
Trickling Filter Effluent	57	16
Surface Wetland Effluent	35	9

**Table 5. COD Removal Performance of 3 Stage Integrated Wetland System (Application Rate 100l/m<sup>2</sup>/d)**

Parameter (mg/l)	Anaerobic Pond		Free Surface Wetland 1	Free Surface Wetland 2
	in	out	out	out
COD	577.5	240.9	109.7	67.7
NH <sub>3</sub> -N	41.4	26.9	26.5	19.8

Yang (1994) reports highly effective performance of a combined Stabilisation Pond and Constructed Wetland system. A primary gravel bed unit consists of 3 parallel gravel, *Frogmouths communis* beds, of a design hydraulic loading of 954 mm/d. Secondary gravel beds receiving the effluent from the primary beds consists of 2 parallel units of *Frogmouths* and *cyperus malaccensis* loaded at 844 mm/d. A Stabilisation Pond system of 3 parallel ponds of lotus, hyacinth and algal-bacterial symbiotic system loaded at 845 mm/d. Final treatment is achieved in a gravel bed system consisting of two *Cyperus* beds and one pond in parallel, designed on a basis of 1007 mm/d. The total system has a surface area of 8 400 m<sup>2</sup> loaded at 370 mm/d. Table 6 illustrates treatment performance over three years. Similarly very effective treatment is reported by Wang (1994) where the system involves an Upflow Anaerobic Sludge Blanket cell, a Hyacinth pond and gravel bed SF Wetlands.

**Table 6. Treatment Performance of Chinese Integrated Wetland System**

Constituent mg/l	Influent	Primary Bed Effluent	Secondary Bed Effluent
BOD	92,8	32,2	-
COD	144,7	83,3	17,2
Suspended Solids	140,9	34,6	26,7

Figure 1 illustrates a cutaway perspective of a small scale domestic Constructed Wetland system (from Steiner 1993). Figure 2 illustrates the Gravel Bed Hydroponic (GBH) Wetland channels of Abu Attwa, Egypt (from Butler 1990). Figure 3 and 4 illustrates the configuration and approach for the vertical flow and recycle Constructed Wetland system for Cresset House residential home in South Africa designed according to the Campshill Trust loading regime of  $\pm 1\text{m}^2/\text{p.e}$  and alternate operation of individual beds. Figure 5 illustrates a decision tree for selecting Constructed Wetland options (from Batchelor 1994).

**Constructed wetlands** like this one are being built throughout the nation to handle wastewater from mostly small rural communities and homes where traditional treatment systems are a problem.

Wastewater flows into the constructed wetland from a septic tank or other type of primary treatment system. Here the wastewater is evenly distributed among the plants where microorganisms and chemical reactions break down organic materials and pollutants.

Constructed wetlands provide simple, effective, and low cost wastewater treatment when compared with conventional systems.

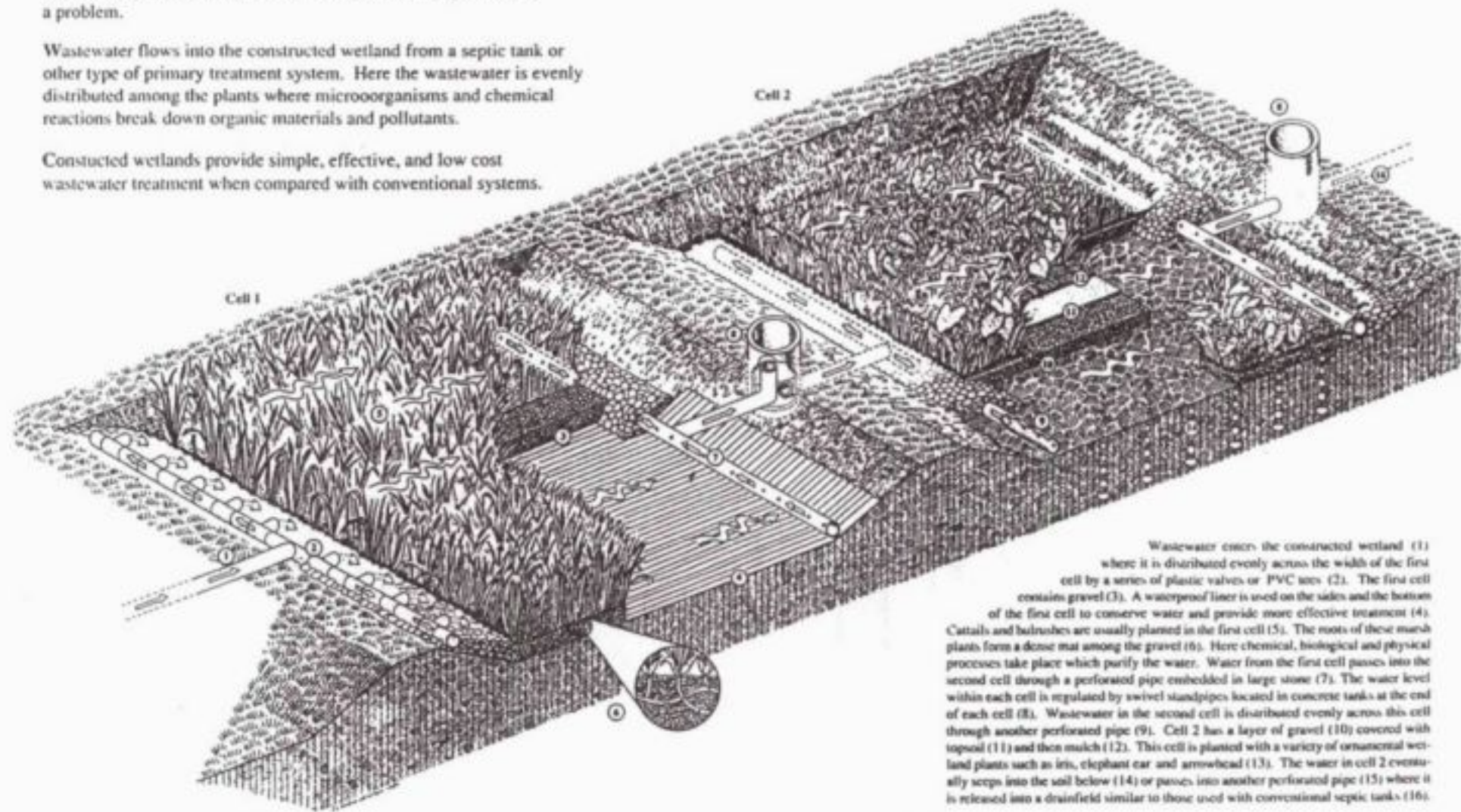

Wastewater enters the constructed wetland (1) where it is distributed evenly across the width of the first cell by a series of plastic valves or PVC tees (2). The first cell contains gravel (3). A waterproof liner is used on the sides and the bottom of the first cell to conserve water and provide more effective treatment (4). Cattails and bulrushes are usually planted in the first cell (5). The roots of these marsh plants form a dense mat among the gravel (6). Here chemical, biological and physical processes take place which purify the water. Water from the first cell passes into the second cell through a perforated pipe embedded in large stone (7). The water level within each cell is regulated by swivel standpipes located in concrete tanks at the end of each cell (8). Wastewater in the second cell is distributed evenly across this cell through another perforated pipe (9). Cell 2 has a layer of gravel (10) covered with topsoil (11) and then mulch (12). This cell is planted with a variety of ornamental wetland plants such as iris, elephant ear and arrowhead (13). The water in cell 2 eventually seeps into the soil below (14) or passes into another perforated pipe (15) where it is released into a drainfield similar to those used with conventional septic tanks (16).

CUTAWAY PERSPECTIVE OF A CONSTRUCTED WETLANDS SYSTEM

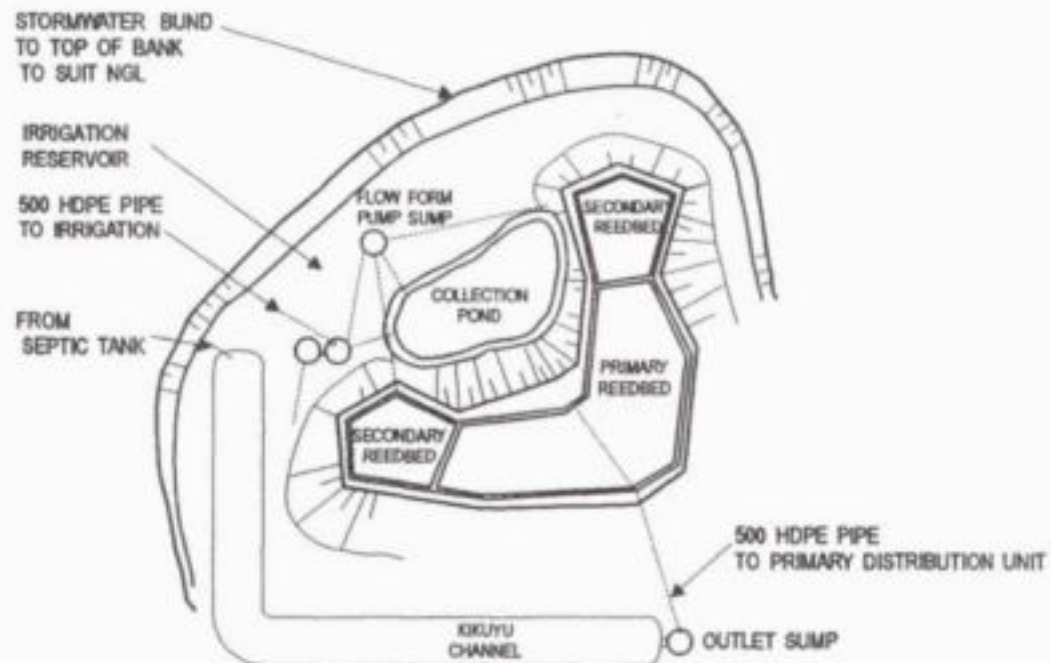

PLAN

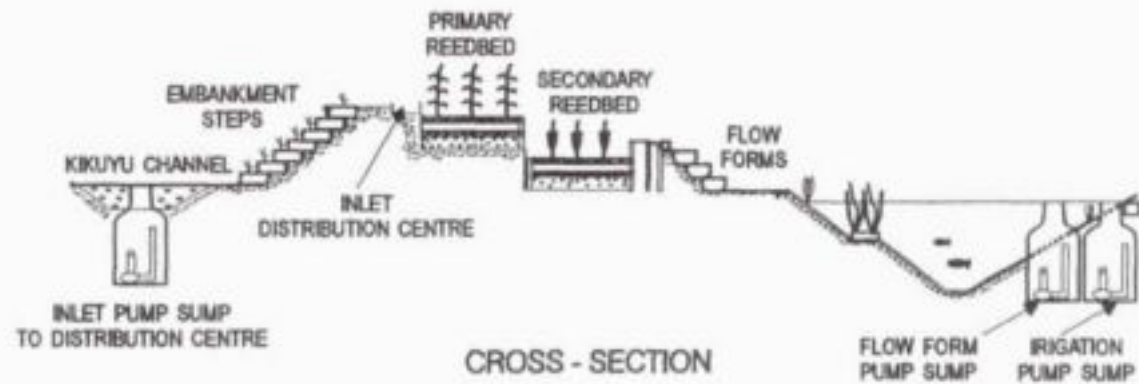

CRESSET HOUSE CONSTRUCTED WETLAND SYSTEM

FIG. No. 3 & 4



Figure 5. Decision Support Tree for Constructed Wetland Treatment System Options  
(Adapted from Batchelor 1994)

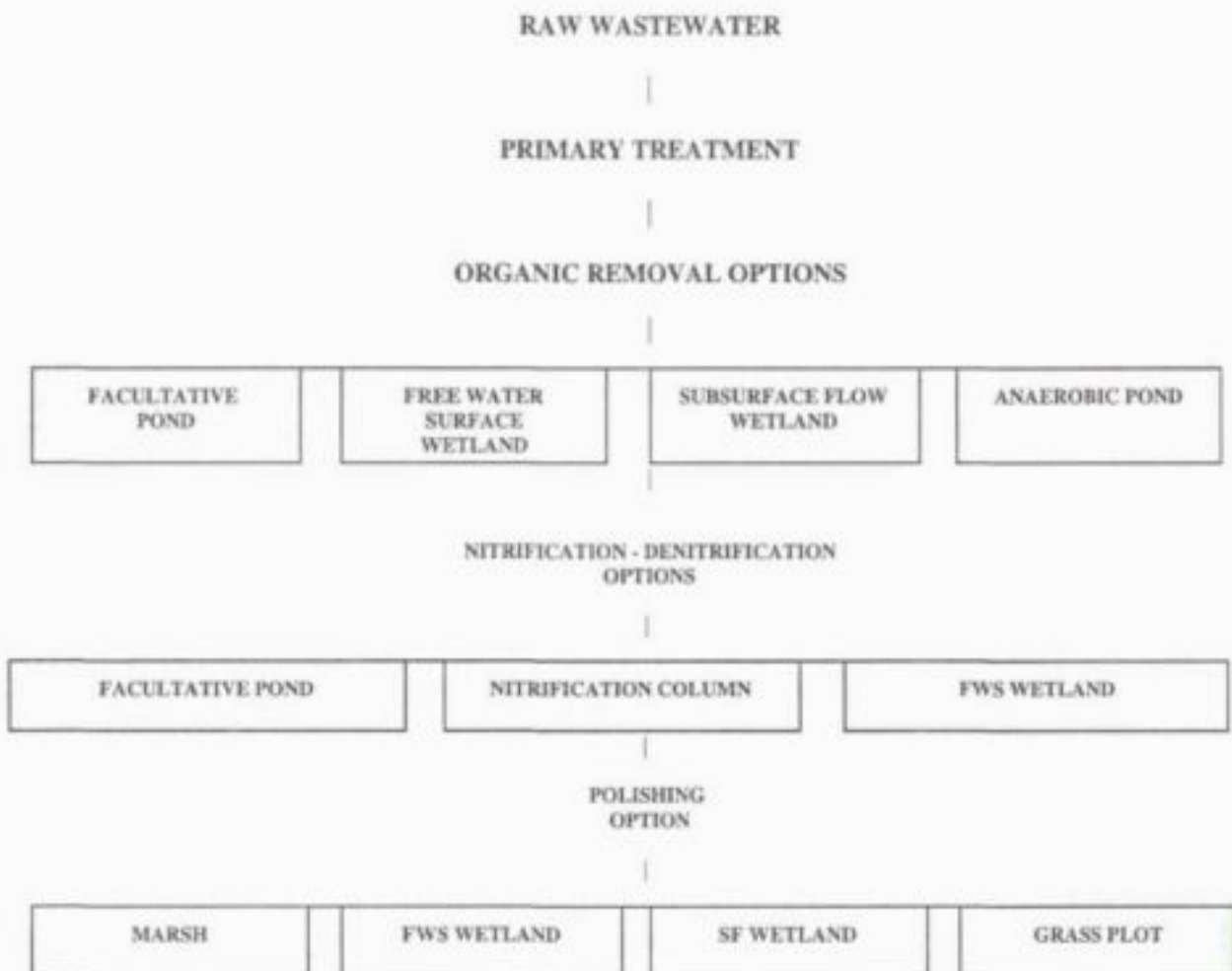

## 5. ADVANTAGES AND CONSTRAINTS OF CONSTRUCTED WETLANDS

Constructed Wetland systems can have certain advantages over conventional treatment systems (adapted from Brix 1987):

- I) - low operating, energy and maintenance requirements;
- ii) - an efficient decentralized approach to wastewater treatment and control;
- iii) - a robust, low rate process they are able to tolerate a wide range of operational conditions;
- iv) - environmentally acceptable offering considerable wildlife conservation potential;
- v) - potential to integrated into existing forms of effluent treatment.

Constraints to the application of Constructed Wetland systems include:

- I) - Land area requires 4-10 times that required for conventional wastewater treatment, and 10-100 times more land where zero discharge is envisaged;
- ii) - Lack of defined design and operational guidelines for the various applications and treatment objectives;
- iii) - Engineering difficulties in ensuring optimal flow of water through extensive shallow open water bodies and/or through the media of the Wetland in subsurface flow mode;
- iv) - The availability and/or cost of suitably permeable media for subsurface flow systems ie sands and gravels;
- v) - The ability to remove nutrients, particularly phosphate;
- vi) - Geographical limitations and availability of suitable plant species;
- vii) - Plant biomass harvesting is constrained by the plant moisture content, difficulties in harvesting from within an operating Wetland system and limited market for removed material;

Table 7. Southern African Constructed Wetlands Systems

SITE	DESIGN FLOW	CONFIGURATION TREATMENT
Daspoort	Variable.	Experimental Integrated Systems.
Letlhabile	2000m <sup>3</sup> /d	Meandering Channel. Tertiary
Karbochem	6 000 m <sup>3</sup> /d.	Meandering Channel. Tertiary
Mpophomeni	2 500 m <sup>3</sup> /d.	Vertical Subsurface Flow Soil Bed. Tertiary
Ladybrand	4 200 m <sup>3</sup> /d.	2 Vertical Subsurface Flow Gravel Beds. Tertiary
Bethlehem	4 200 m <sup>3</sup> /d.	5 Horizontal Subsurface Flow Gravel and Ash Beds. Tertiary
Warmbaths	17,5 m <sup>3</sup> /d.	Single Horizontal Subsurface Flow Soil Bed. Secondary
Kwazulu Hospital	80 m <sup>3</sup> /d.	Single Horizontal Subsurface Flow Soil Bed. Secondary
Moeketsi	200 m <sup>3</sup> /d.	3 x Dual Horizontal Subsurface Flow Soil Beds. Secondary
Middleburg	80 m <sup>3</sup> /d.	Single Horizontal Subsurface Flow Gravel Bed. Secondary
Potchefstroom	80 m <sup>3</sup> /d.	Integrated Channel. Tertiary
Klipdrift	40 m <sup>3</sup> /d.	Single Horizontal Subsurface Flow Gravel + Ash Bed. Secondary
Pietersburg Truck Stop	80 m <sup>3</sup> /d.	Double Gravel Bed and Maturation pond. Secondary
Paarl	35 m <sup>3</sup> /d.	Single Gravel Bed and Maturation pond. Secondary
Bakubung	<50 m <sup>3</sup> /d.	Secondary Horizontal Subsurface Flow Ash Bed. Secondary
Oil Industry	Variable	Subsurface Flow Gravel Beds. Secondary
Kruger Park	Variable	28 Sand Beds. Secondary
Grabies Falls	<50 m <sup>3</sup> /d.	Double Sand Beds. Secondary
Mabulane	<20 m <sup>3</sup> /d.	Single Horizontal Subsurface Flow Sand Beds. Secondary
Selaris Pass	<20 m <sup>3</sup> /d.	Single Horizontal Subsurface Flow Soil Bed. Secondary
Felixon Mill	400 m <sup>3</sup> /d.	Vertical Subsurface Flow Sand Bed. Secondary
Midrand	20 m <sup>3</sup> /d.	Integrated biofilter/Wetland/flowform. Secondary
Freemansheim	200 m <sup>3</sup> /d.	Dual Horizontal Subsurface Flow Soil Beds. Secondary
Kranskop	200 m <sup>3</sup> /d.	Single Horizontal Subsurface Flow Soil Bed. Secondary
Reddersburg	500 m <sup>3</sup> /d.	Dual Secondary Horizontal Subsurface Flow Gravel Beds Secondary
Nkowa-kowa Township	2 200 m <sup>3</sup> /d.	6 Tertiary Soil Beds. Tertiary
Olifantsvlei Stormwater	Variable	10 ha Wetlands. Tertiary
Umzimkulu Mill	4 000 m <sup>3</sup> /d.	5 ha Ash Dam/Wetlands. Secondary
Simonstown	2 000 m <sup>3</sup> /d.	6 ha Conservation
Milnerton	5 000 m <sup>3</sup> /d.	4 ha Tertiary. Conservation
Van Dykesdrift	2 000 m <sup>3</sup> /d.	8 ha Minewater. Conservation
Duvha Mine	200 m <sup>3</sup> /d.	6 Horizontal Subsurface Flow Sand Beds. Minewater. Seep
Vaal Reefs Mine	1 000 m <sup>3</sup> /d.	6 Vertical Subsurface Flow Slime/Soil Beds. Tertiary
Moeking	200 m <sup>3</sup> /d.	2 Horizontal Subsurface Flow Soil Beds. Tertiary
Mankwe	200 m <sup>3</sup> /d.	4 Horizontal Subsurface Flow Soil Beds. Tertiary
Namibian Hospital	250 m <sup>3</sup> /d.	Dual Beds and Maturation Ponds. Secondary
Namibian Border Post	16 m <sup>3</sup> /d.	Dual Soil overlying gravel Beds. Secondary
Namibian Mission	± 450 m <sup>3</sup> /d.	Single Subsurface Flow Soil Bed. Secondary
Namibian Farm School	± 200 m <sup>3</sup> /d.	Single Subsurface Flow Soil Bed. Secondary
Namibian Church & Hospital	<20 m <sup>3</sup> /d.	Single Subsurface Flow Soil Bed. Secondary
Hlatikulu	- 1500 person	CSIR Integrated Wetland. Secondary
Nkobo	- 1200 person	CSIR Integrate Wetland. Secondary
Smero School	- 1000 person	CSIR Integrate Wetland. Secondary
Nietgedacht Primary School	- 400 person	CSIR Integrated Wetland. Secondary
Carnivore Restaurant	Kenya- 500 person	CSIR Integrate Wetland. Secondary
Cookes Lake Project	- 3.5 Ml/day	Polishing Wetland and bird sanctuary
Bon Accord Quarry	24 person CSIR	Integrated Wetland. Secondary
Morgenhof Estate	30m <sup>3</sup> /day	CSIR integrated system Wetland. Secondary
Makalali Lodge	100 person	CSIR Integrated Wetland. Secondary
Tau Lodge	40 m <sup>3</sup> /day.	CSIR Integrated Wetland. Secondary
Barwick School	350 person	CSIR Integrated Wetland. Secondary
St Brillades	32 person	CSIR Integrate Wetland. Secondary
Canadian Embassy	16 person	CSIR Integrated Wetland. Secondary
Malalane	250 person	CSIR Integrated Wetland. Secondary
CSIR Pretoria	Variable	CSIR Integrated Wetland for campus facility discharges and stormwater
Port Elizabeth.	Variable	Wetland system to treat base flow in Motherwell Canal (Pilot Project).
Chipinge.	Variable	Zimbabwe. Oxidation pond upgrade from 750 m <sup>3</sup> /day to 2,1Ml/day.
Miscellaneous Schools.	Variable	CSIR Integrated Wetland systems for sewage treatment

## 6. SOUTH AFRICAN CONSTRUCTED WETLAND SYSTEMS

Table 7 illustrates Constructed Wetlands applied in Southern Africa. The following section summarises the key characteristics of a selected number of the systems to highlight the flexibility in design and application that has been applied in South Africa.

### 6.1 Mpophomeni

A single SF vertical flow 1.5 m deep soil Wetland of 2 500 m<sup>2</sup> surface area. Constructed to polish Biofilter effluent to a phosphate level of <1 mg/l at a maximum hydraulic loading of 200mm/d. The effluent is introduced from a central distribution channel to the surface of the soil bed, planted with *Frogmouths Spp*, where it is designed to filter vertically through the media into a gravel drainage system. The final effluent is discharged onto a marshland above the sensitive Midmar dam.

### 6.2 Letlhabile

The Letlhabile FWS channel Wetland arrangement consists of 10 channels, 5 m wide by 300 m long, operated in parallel pairs with a water depth of the order of 500 mm and planted with sedges. The system was constructed to assist in phosphate removal and tertiary polishing from a domestic wastewater after treatment through a combined Biofilter and Oxidation pond arrangement, a variation of the 'PETRO' concept.

### 6.3 Ladybrand

The Ladybrand SF Wetland system has two vertical flow gravel beds for the polishing of the algal solids and residual nutrients generated by an aerated lagoon system after primary anaerobic ponds. The media is a graded fine gravel overlying a coarse gravel base layer, and planted with *Typha Sp*. Each cell is 85 m long by 70 m wide, designed to receive nominally 2 150 m<sup>3</sup>/d from the pond system. Overflow from the facultative pond is introduced to the Wetland to maintain a water depth of  $\pm$  500 mm, filtering downwards through the gravel to be collected in an under-drainage network.

### 6.4 Bethlehem

The Bethlehem SF Wetlands consists of 5 previous Maturation ponds providing a combined surface area of  $\pm$  2 hectares, converted to operate as horizontal flow SF, gravel and ash units, for the polishing of effluent from a Biological Filter and Activated Sludge system. The beds, planted with *Frogmouths Sp* reed, are operated as parallel units.

## 6.5 Kruger National Park

The Kruger National Park has readily adopted the Wetland technology for the treatment of the wastewaters generated by the camps throughout the park. The larger camps, such as the Lethaba, Skukuza and Olifants, which accommodate up to 3 000 persons are provided with conventional Oxidation Pond systems, whilst the smaller camps of Crocodile Bridge and Shingwedzi are serviced by septic tanks. The Wetlands units are constructed as horizontal flow SF units operating with two cells in series. The sizing is based on accommodating the peak flow of the maximum number of visitors, or 5 m<sup>3</sup>/person. The beds are nominally 1.0m deep of a sand media and planted generally with *Frogmouths Sp.*

## 6.6 Pilansburg Game Reserve

The Wetland system at the Bakgatla Gate site of the Pilansberg National Park was constructed to treat septic tank effluent for a peak population of 300 persons, in a SF horizontal flow gravel bed planted with *Frogmouths Sp.* The Wetland was a single unit 60 m wide by 20 m long to accommodate available space and optimise the hydraulic distribution of the wastewater across the inlet zone. The media is a sand base with inlet and outlet areas of graded gravel.

## 6.7 Pietersburg Truck Stop

A truck rest stop, cafeteria and petrol station in Pietersburg has a 2 stage horizontal flow SF, gravel channel Wetland constructed to accommodate the septic tank effluent discharge flow of 50 m<sup>3</sup>/d. Each cell being 5 m wide, 50 m long by 0.75 m deep, and planted with *Typha Sp.*

## 6.8 Klipdrift

A construction camp and service depot for the railways at Klipdrift had a single stage horizontal flow SF gravel and ash Wetland constructed to treat septic tank effluent at a flow of 40 m<sup>3</sup>/d. The cell was nominally 7.5 m wide, 30 m long by 0.75 m deep, and planted with *Frogmouths Sp.*

## 6.9 Middelburg

A rest stop, cafeteria and petrol station in Middelburg had a single stage horizontal flow SF gravel Wetland constructed to polish the effluent from a Rotating Biological Contractor system prior to chlorination and discharge. The design flow was a peak flow of 80 m<sup>3</sup>/d. The cell was nominally 10 m wide by 20 m long by 0.45 m deep, and planted with *Typha Sp.*

### 6.10 Reddersburg

The Reddersburg SF Wetland system has two parallel gravel beds for the polishing of the algal solids and residual nutrients generated in a 5 pond facultative lagoon system after primary anaerobic ponds. The media is a graded fine gravel 300 mm depth overlying a  $\pm 150$  mm coarse gravel base layer, and planted with *Typha Sp.* Each cell is 28 m long by 32.5 m wide, designed to receive nominally 250 m<sup>3</sup>/d from the pond system.

### 6.11 Kranskop

A 2 unit parallel horizontal flow SF Wetland systems were constructed in Kranskop according to the EC Constructed Wetland Design Guidelines (Cooper 1990) to treat septic tank effluent on a nominal basis of 5m<sup>3</sup>/person. Each cell has a length of 40 m by width of 55 m. The media is a graded fine gravel  $\pm 600$  mm depth, and planted with *Frogmouths Sp.* The septic tank effluent flow is nominally 1 000 m<sup>3</sup>/d.

### 6.12 Friemansheim

Two independent horizontal flow SF Wetland systems were constructed in Friemansheim according to the EC Constructed Wetland Design Guidelines to treat septic tank effluent of a nominal basis of 5m<sup>3</sup>/person. System one has a length of 35 m by width of 22 m and system two a length of 41 m by width of 35 m. The media is a graded fine gravel 5 - 10 mm of  $\pm 600$  mm depth, and planted with *Frogmouths Sp.* The combined septic tank effluent flow is nominally 200 m<sup>3</sup>/d.

### 6.13 Warmbaths Cotton Gin

The Warmbaths Cotton Gin horizontal flow SF Wetland was sized to accommodate the septic tank effluent discharge at a peak flow of 17.5m<sup>3</sup>/d, being 35 m long by 16 m wide, and comprised of a coarse sandy clay soil planted with *Typha and Frogmouths Sp.*

### 6.14 Karbochem Newcastle

The Karbochem Wetland system, resembling Lethabile, consists of a series of 6 interconnected open channels, each with a length of  $\pm 750$  m by  $\pm 8$  m wide and planted with *Typha Sp.* The system is operated in a shallow FSW mode to provide tertiary treatment to the process wastewaters and domestic sewage from the Karbochem industrial chemicals plant after conventional primary sedimentation, oil capture and extended activated sludge treatment at a maximum daily volume of the order of 6 000 m<sup>3</sup>/d.

### 6.15 Midrand Residential Home

The Cresset House residential home in Midrand accommodating  $\pm$  100 persons has an integrated vertical flow Wetland system to treat septic tank effluent. It is designed on the basis of the Camps Hill Trust system in the EC Constructed Wetland Design Guidelines. It consists of an SF gravel channel 40 m long by 3 m wide and nominally 500 mm deep overlaid with kikuyu grass. The effluent is pumped to 4 parallel vertical flow multiple sand media Wetland units which are operated on an alternate day basis, decanting to 2 vertical flow secondary sand media beds. Each Wetland cell is planted with *Frogmouths Sp.* The design basis is 1 m<sup>2</sup>/person.

### 6.16 Mount Grace Hotel

Mount Grace Hotel has an integrated Wetland system to polish effluent from an existing Rotating Biological Contactor (RBC). The kitchen and domestic sewage at 90 m<sup>3</sup>/d pass through the RBC prior to a series of 5 surface flow Wetland units of  $\pm$  200 m<sup>2</sup> surface area, and a final maturation pond. The water depth within the Wetland units varies between 20 and 100 mm. A variety of plant species were planted to add to the overall aesthetics of the system.

### 6.17 CSIR Campus Wetland

The CSIR campus in Pretoria has an integrated Wetland system to treat discharges from the various research facilities and site runoff. The system consists of both SF and FWS cells and shallow and deep open water areas. It incorporates a variety of aquatic plant species including *Eichornia*, *Lemna*, *Typha* and *Frogmouths Sp* and various rushes and sedges to enhance the overall aesthetics.

### 6.18 Potchefstroom

The Naschem industrial site in Potchefstroom has an integrated Wetland system to treat treated domestic sewage discharges from a mechanical Activated Sludge plant. The Wetland consists of meandering, narrow (nominally 2 m wide), FWS cells interspersed by shallow and deep open water areas traversing approximately 300 m across a golf course. It incorporates a variety of trees and shrubs as well as aquatic plant species including *Lemna*, *Typha* and *Frogmouths Sp* and various rushes and sedges to enhance the overall aesthetics of the system.

### 6.19 Makwane

At Makwane two parallel horizontal flow soil bed SF Units each of 350 m<sup>2</sup> surface area were constructed to receive a hydraulic loading of 100 mm/d. The pretreatment involves 3 facultative Oxidation ponds each of 680 m<sup>2</sup> surface area, and a nominal hydraulic retention time of 9 days. The bed media is a 0,6 m thick clayey sand topped with a 200 mm layer of stone and planted with *Frogmouths Sp.*

### 6.20 Umzimkulu Sugar Mill

Umzimkulu sugar mill in Natal utilised the ash disposal dam to discard waste ash and to treat wastewater. The ash dam had a surface area of 19 000 m<sup>2</sup> to which 840 m<sup>3</sup>/d of effluent and 7 200 m<sup>3</sup>/d ash were disposed. Filtration of the effluent through the ash matrix and the Wetland plants developed on the surface of the ash dam provided the efficient wastewater treatment.

### 6.21 Felixston Sugar Mill

The Sugar Technology Department (STD) of Tongaat Hulett Sugar designed a Wetland to receive effluent after anaerobic pretreatment and Activated Sludge aeration. A 2 000 m<sup>2</sup> vertical flow SF bed was constructed with river sand and planted with *Frogmouths Sp.* The design loading was 200 mm/d of the secondary wastewater.

### 6.22 Milnerton

Milnerton Municipality have created a ± 4 ha FWS Wetland system adjacent to the sewage treatment works to polish the final discharge after conventional Biological Filtration and flow balancing in maturation ponds, prior to it being released into the Rietvlei natural Wetland area. The system was created by berming off a section of the natural Wetland and establishing 4 cells nominally operated as two pairs through which the effluent percolates through the predominantly *Typha Sp* vegetation mass and exit in a nominally purified state into the main river system of the natural Wetland.

### 6.23 Oil Industry Wetlands

Two truck washing Wetland systems have been constructed at Pretoria and Secunda oil depots. These are designed to operate on a vertical flow SF format through a layer of coarse gravel ± 700 mm deep to a subsurface drainage layer, and planted with *Typha Sp.* A maximum loading rate of 700 litres/m<sup>2</sup>/week and 400 m<sup>2</sup> in surface area. A third system utilizes an existing Wetland area to receive site drainage and washings after an oil-water separator unit.



#### 6.24 Bannockburn Minewater

The Bannockburn FWS Wetland system has been constructed to receive minewater emanating from the open shafts of an abandoned coal mine system at a rate of approximately 10/second and the surface run-off and leachate from rehabilitated spoil dumps. The system has been separated into an upper section with 4 units covering an area of  $\pm 1.5$  hectares planted with *Typha Sp.*, and a lower section with a further 4 units and additional 1 ha.

#### 6.25 Van Dykes Drift Mine

A 20 ha Wetland system was created as part of the coal mines rehabilitation programme of a previously opencast pit area. The objectives were to improve the quality of poor quality water in a stream crossing the site, to treat pollution arising from on-going mining operations in the area, and ultimately to operate as a passive treatment system after mine closure, whilst encouraging bird and wildlife to an otherwise relatively barren area.

#### 6.26 Atlantis Groundwater Recharge Wetland

The Atlantis Wetland system is a component of the groundwater recharge system in Atlantis which receives seepage from the wastewater pond system. There are a total of 12 ponds in the system of which only pond 6 is recognised as a Wetland, being dominated by emergent macrophytes. This has a nominal capacity of 44 000 m<sup>3</sup> and an active surface area of the order to 3 000 m<sup>2</sup> receiving approximately 2 000 m<sup>3</sup>/d treated sewage effluent and between 3 and 4 000 m<sup>3</sup>/d stormwater and groundwater infiltration.

#### 6.27 Sandton Urban Wetlands

Sandton is promoting the development of open space and parkland areas which include Wetland areas. An example is the Sandspruit tributary of the Braamfontein Spruit, which is residentially developed along its length. The Sandspruit has an average dry weather flow of the order of 5 l/second, increasing significantly in storm conditions. To reduce the flood water velocity, and thereby protection of the Spruit, the Municipality has constructed a series of dammed, open areas, linked by the Spruit base which is dominated by Wetland plant and tree species.

## 7. PERFORMANCE REVIEW OF SELECTED CONSTRUCTED WETLAND SYSTEMS

### 7.1 Mpophomeni

#### 7.1.1 System Configuration

Mpophomeni in KwaZulu Natal is situated on the eastern shore of Midmar Dam, for which the sewage treatment is served by a conventional Biological Trickling Filter (Biofilter) works to which has been added the Constructed Wetland for polishing final effluent.

The single vertical flow Wetland of 2 500 m<sup>2</sup> surface area was designed to treat 500 m<sup>3</sup>/d to meet a maximum phosphate level of 1 mg/l P, at a unit surface loading of 200 mm/d. Biofilter humus tank effluent is introduced from a central concrete channel to the surface of a 1.5 m deep, phosphate deficient, acidic soil bed, planted with *Frogmouths Sp.* The wastewater percolates vertically through the soil to a drainage system of crushed gravel protected by a bidum geotextile membrane and overlying the base hyperplastic liner. The final effluent is discharged to a marshland via a series of Maturation or Stabilisation ponds (Figure 6).

#### 7.1.2 Wastewater Treatment Performance

The Wetland has suffered poor hydraulic permeability, with consistently of the order of 90 - 95% of inflow passing across the bed surface rather than through the vertical profile. As the system has generally received significantly greater hydraulic loading ( up to 680 mm/d), as compared to the design loading, this 5-10% of total flow represents a volume equivalent to 30-50% of the initial design load of 200 mm/d.

Despite the system not totally operating as designed, treatment performance has been good. Table 8 illustrates treatment performance over the first 5 years of operation for the water passing through the media. Table 9 illustrates consolidated data sets for subsequent annual periods for wastewater passing both over the surface of the Wetland and through the Wetland. In each case all concentrations with the exception of E.Coli comply with General Standard, and for water passed through the vertical profile, the P concentration is generally < 0.5 mg/l. Continuous monitoring exercises undertaken over periods of 48 hours confirmed the ability of the Wetland system to achieve a high level of treatment performance in both the surface and subsurface flow condition. Table 10 illustrates one data set.

No significance of temperature, or plant growth condition, has been identified despite seasonal effects on incoming wastewater, particularly winter ammonia elevations. This indicates the plant litter acts as a biological support media whether or not the above ground plant structures are active. It also confirms that plant uptake of pollutants is minimal relative to the high hydraulic, and associated nutrient, loadings to which the surface flow system is exposed.

Based upon an estimated average surface loading of 1 700 m<sup>3</sup>/d and bed area of 2 500 m<sup>2</sup> (680 mm/d), the contaminant removal rates ranged from 0.7 - 1.5 g/m<sup>2</sup>/d for NH<sub>3</sub>-N, 3.0 - 6.0 g/m<sup>2</sup>/d for NO<sub>3</sub>-N, 12 - 20 g/m<sup>2</sup>/d for COD and 7.5 - 20 g/m<sup>2</sup>/d for SS.

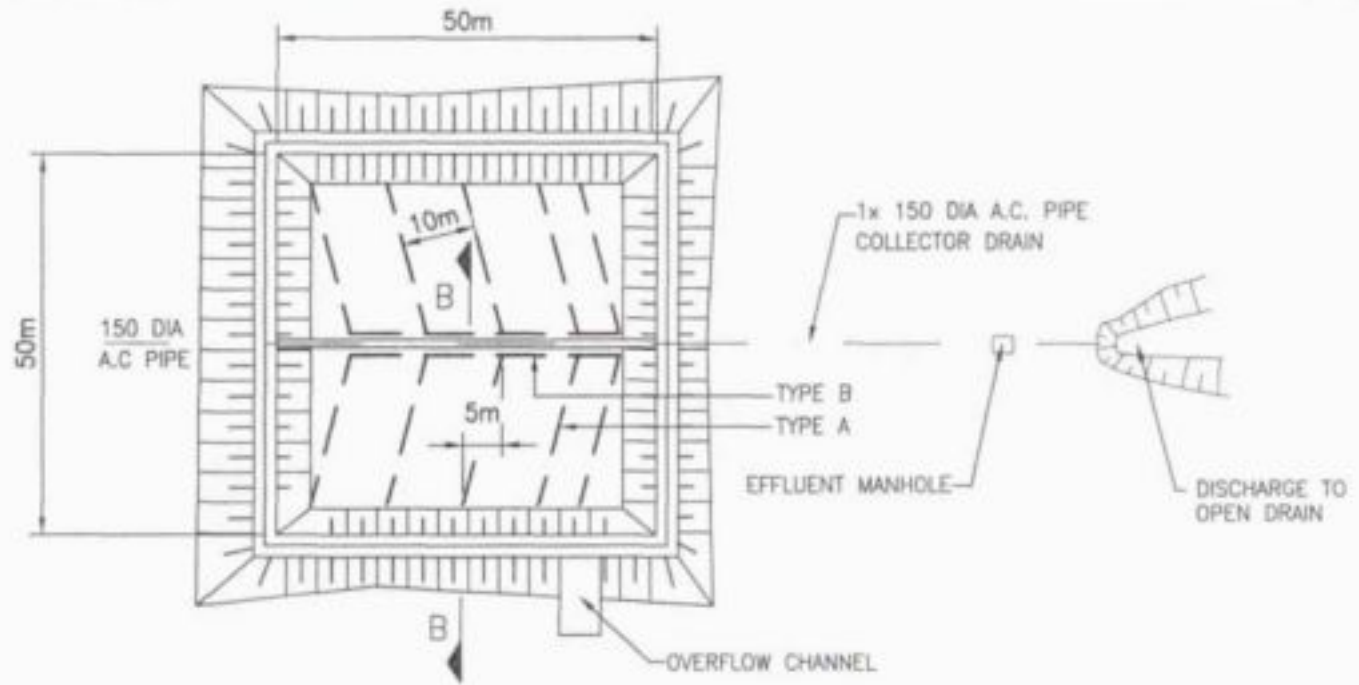

PLAN OF REED BED

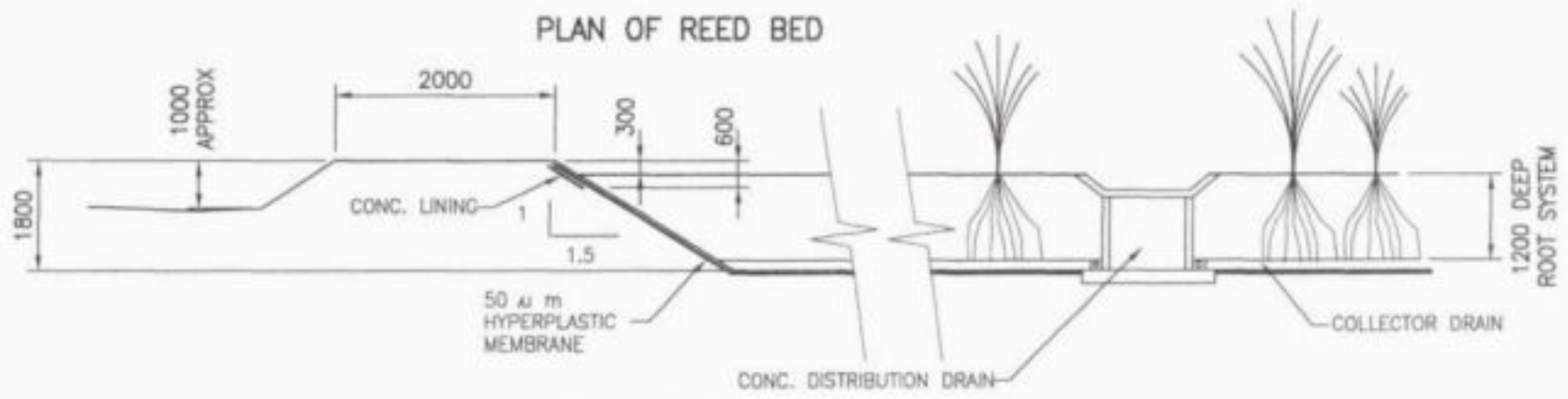

SECTION B-B

MPOPHOMENI CONSTRUCTED WETLAND  
PLAN AND CROSS SECTION

FIG No.  
6

**Table 8 Wastewater Treatment Performance of Mpophomeni Constructed Wetland (Initial 5 year period)**

Determinant	Inflow mg/l	Outflow mg/l	% Removal
pH	7.6	7.7	-
Alkalinity as CaCO <sub>3</sub>	43.2	86.1	-99.3
Conductivity mS/m	59.8	46.8	20.1
NO <sub>3</sub> -N	46	15.1	67.2
NH <sub>4</sub> -N	2.8	1.2	57.1
PO <sub>4</sub> -P	7.0	0.87	87.7
SS	39.1	13.7	65.0
COD	64.1	22.5	64.9
TOC	11.6	5.4	53.4
PV	10.5	5.0	50
Coliforms/100 ml	5.6 x 10 <sup>5</sup>	5.5 x 10 <sup>4</sup>	90.1
E.Coli/100 ml	1.6 x 10 <sup>5</sup>	3.4 x 10 <sup>3</sup>	97.9
F.Strep/100 ml	3.7 x 10 <sup>4</sup>	1.3 x 10 <sup>3</sup>	96.5

**Table 9 Wastewater Treatment Performance of Mpophomeni Constructed Wetland (Indicating quality of overflow and underflow)**

Determinant	Inflow mg/l	Overflow mg/l	Underflow mg/l
pH	7.5	7.3	7.1
Alkalinity as CaCO <sub>3</sub>	83.5	105.5	179
Conductivity mS/m	49.9	44.9	52.4
NO <sub>3</sub> -N	15.6	6.3	0.8
NH <sub>4</sub> -N	3.6	2.65	3.24
PO <sub>4</sub> -P	4.76	3.0	<0.5
TP	5.5	3.8	<0.5
COD	63.1	40.4	<33
OA	6.2	4.1	3.3
SS	20.2	16.4	29
E.Coli/100 ml	550 000	2 500	28

**Table 10 Mpophomeni Constructed Wetland Treatment Performance as Illustrated by a 48 hr Composite Sampling Exercise**

Determinant	Inflow mg/l	Overflow mg/l	Underflow mg/l
COD	95	25	5
NH <sub>4</sub> -N	9.6	1.0	2.5
NO <sub>3</sub> -N	20.0	8.5	0.1
PO <sub>4</sub> -P	6.0	6.0	0.1
SS	38	2	8

Alkalinity significantly increases as the wastewater flows through, and over, the Wetland despite nitrification occurring and creating a demand on the alkalinity. Denitrification generates some alkalinity, but inadequate to account for increases of 20 - 30 mg/l in the overflow, and 90 - 120 mg/l in the underflow. Additional buffering is generated as wastewater passes through the plant, microbial and soil/sediment matrix, some derived from Ca in the soil, and some from gypsum added to the soil in an attempt (unsuccessful) to improve permeability.

Denitrification occurs in the overland flow despite predominantly aerobic conditions where microclimates in the dense plant litter and sediments are anoxic and provide carbon. The surface flow can achieve TN removal, at the expense of TP removal. Lower nitrification at lower influent concentrations is believed to be a result of oxidation of in-situ nitrogenous compounds, and masks the full capacity of nitrification that the surface flow system is capable of. Nitrification in the underflow is limited by oxygen availability, indicating that deep soil beds are not suitable for nitrification.

Short-circuiting of the flow path, as well as the generation of algae in the open water areas has been found to be responsible for the release of SS from the bed surface into the effluent. Elevated underflow SS levels also result from the precipitation of iron oxides. Although clear in its fresh state, within 4 hours the water becomes turbid as iron oxides precipitates, and are then captured as SS upon filtration.

Although some TP and PO<sub>4</sub> removal has been achieved at lower surface loading, at high loadings the removal has been limited. Release of P into the effluent is believed to be a result of changes to the flow regime, disturbance of sediments and release of suspended and algae solids containing P. Pathogen removal of > 10<sup>5</sup>/100 ml in the subsurface flow is significant whilst removal in the surface flow of 10<sup>1</sup> - 10<sup>2</sup>/100 ml is primarily a result of the minimal HRT provided by the severe short-circuiting.

### 7.1.3 Hydraulic Characteristics

The vertical throughput apparently dropped steadily over the first year of operation and has subsequently remained relatively stable. This suggests this is likely to be the long-term hydraulic capacity of the system. Although, after the bed has been "off-line" for maintenance permeability improves, supporting the contention that resting beds assists flow by allowing degradation of the coating slimes layers. Hydraulic capacity in the vertical downflow regime is found to be limited, both by the permeability of the soil and by the development of slime coatings. Once a slimes layer has formed, potential for water to pass through the soil is only slightly affected by the permeability of the main bed depth. Table 11 illustrates soil characteristics of the vertical profile of the bed.

Although there is an increased clay content at the low levels, this is not in a dispersed form that could decrease permeability. The character of the surface layer determines the permeation potential, the total bed depth has little influence. It would appear not to matter whether the bed is 300 mm or 1 500 mm deep in its ability to transfer water, although depth does influence HRT, and opportunities for contact between the wastewater pollutants and chemical, biological and physical components of the soil.

**Table 11. Particle Size, Distribution Root and Organic Matter Content at Different Depths of Mpophomeni Constructed Wetland**

Depth (cm)	Particle Size Distribution			Root Material Imm (g/m <sup>2</sup> )	Organic Matter Imm (%)
	% Sand	% Silt	% Clay		
0 - 3	62	17	21	49,5	9,4
0 - 30	46	20	34	735,4	10,0
30 - 60	60	14	26	717,7	9,9
60 - 90	61	5	34	73,3	7,9
90 - 120	23	16	61	72,8	7,9
120 - 150	26	16	58	61,1	9,6

A series of tracer studies with sodium fluoresceine were undertaken to assess the surface and subsurface flow conditions of the bed. While an HRT of  $\pm 8 - 12$  hours was calculated the tracer dye was observed within 1 h for each of the tracer runs and essentially independent of inflow volume for each specific run, and proceeded to emerge only over a further 2 hours. The low relative flow through the vertical profile, and the rapid short-circuiting of the surface flow prevented adequate dye from passing through the vertical profile to confirm vertical hydraulic

conditions, though a limited amount was observed in excess of 24 hours after introduction, illustrating some ingress of the dye into the vertical profile. The implication is that, rather than the inflow being equally distributed across the Wetland surface, the system is dominated by preferential flow which reduce the ability of the Wetland to achieve the desired degree of wastewater pollutant reduction.

Further evidence of preferential surface flow paths has been the presence of scouring of the Wetland surface, and associated litter between the inlet and outlet zones whilst encouraging sediment deposition to its edges, and localised ice covering during winter periods.

#### 7.1.4 Phosphate Partitioning

As the system was designed for phosphate removal, Umgeni Water undertook soil partitioning exercises within the vertical profile. Phosphate content was found to be highest adjacent to the bed surface (Table 12), consistent with a chemical adsorption/precipitation mechanism. This would suggest that the Mpophomeni Wetland has P removal capacity available for many years.

#### 7.1.5 Pilot Studies

In an attempt to solve the permeability problems, pilot trials were instituted by Umgeni Water using varying ratios of sand and phosphate deficient clay soil. Significant improvement in permeability could be achieved without compromising phosphate removal when a ratio of 3:1

**Table 12. Distribution and Partitioning of Phosphorous in Mpophomeni Constructed Wetland**

Depth (cm)	Exchangeable -P (mg/kg soil)	Metal Bound Extractable P (mg/kg soil)
0 - 3 (surface)	7,4	26,7
0 - 30	2,4	9,4
30 - 60	1,7	7,1
60 - 90	2,2	7,4
90 - 120	1,4	7,2
120 - 150	2,5	8,4
Blank	-	8,7

mixture of clay and sand was used. However at high loading rates, the beds could still maintain permeability but P removal became saturated, and overall pollutant removal capacity



declined. At loadings of 140 mm/d the pilot units were able to achieve 76.5% P removal; 74% NH<sub>3</sub>; 50% PV; 31.2% NO<sub>3</sub> and 95.8% E.coli. At 250 mm/d the P removal reduced to 60%. At loadings of 80 mm/d the removal efficiency increased to allow < 1 mg/l effluent P to be achieved, associated with NH<sub>3</sub>, COD, SS and NO<sub>3</sub> removals.

### 7.1.6 Vegetation Development

Although the Wetland gives appearance of being a dense stand of *Frogmouths*, with which the Wetland was initially planted, behind the ± 2 m 'edge effect' the Wetland is a patchwork of localised *Frogmouths* growth interspersed with *Typha* stands and open water areas, supporting *lemna* and grasses. Development of *Typha* has occurred through natural establishment, primarily restricted to the drier edges of the bed and in some open areas within the bed. Sedges and rushes have also established, as well as of grass species particularly around the edges, and extending into the flooded areas of the Wetland.

Table 11 also indicated the relative root development within the vertical profile of the bed. Core samples indicate a poorly developed root system, 85% of root, occurring in the 0 - 60cm region. As the majority of the bed depth is root free the presence of the plants has little impact upon the long-term hydraulic potential, and the limited improvement in flow through potential over several years of operation, indicates that the development of the plants root system does not significantly improve permeability.

### 7.1.7 Management

As there is no facility to alternate the surface water depth it is not possible to effectively regulate the hydraulic loading of the Wetland, or to use this management tool to control mosquito larvae development. However, the location at a distance from the local community has limited mosquito nuisance problems. Similarly the apparent well developed ecological balance and natural predators of mosquito larvae appears to operating effectively.

It would also appear that the low organic loading is not encouraging mosquito development to the levels that may be expected if the system became anaerobic. Excessive organic loading to the Wetland is not expected as the works has well trained operators running the plant on a day to day basis. The works has also by-pass storage facilities in the event of excess stormwater ingress, or overloading, which should further ensure that effluents reaching the Wetland, and subsequently leaving the site are well controlled and acceptable.

Mpophomeni Wetland has been harvested and the surface cleared on several occasions since its initial commissioning. This has been undertaken to minimise sealing effects developing as a result of influent solids, degrading plant litter, and microbial biomass growth in the treatment and stabilisation of the wastewater. However, these clearing operations have had little long-

term effect upon the permeability of the resident soil and its ability to accommodate the wastewater in the vertical profile, and with the introduction of the full flow through the Wetland it is no longer intended that harvesting will be undertaken. If necessary the bed will be burnt to clear excess above ground vegetation.

### 7.1.8 Management Recommendations

- 1 Install dividers across the Wetland surface to create a meandering channel flow.
- 2 Install outlet weir to permit management of the water depth to assist management of HRT and mosquito control.
- 3 Operate with a water depth of 500 mm to optimise the HRT through the Wetland and increase the hydraulic head encouraging vertical percolation. External berms may be raised to accommodate the increased surface water depth.
- 4 Introduce *Tilapia* to assist in nuisance insect and algae control. Grass carp may be introduced to control *lemna* and excessive litter development
- 5 Provide by-pass facility to permit clearing of the bed occasionally.
- 6 If P removal is a primary objective reduce loading to achieve required balance between surface flow and underflow after amendment of hydraulic control as above.

## 7.2 LETLHABILE

### 7.2.1 System Configuration

Lethabile sewage treatment works receives 1 500 - 2 800 m<sup>3</sup>/d of predominantly domestic sewage from the town of Lethabile in the Western Transvaal. Treatment is a variation of the 'PETRO' concept utilising Anaerobic Pond primary treatment, Facultative Oxidation Ponds and Biological Trickling Filters and a meandering channel Wetland tertiary polishing stage to Petro system discharge, primarily for phosphate removal by plant uptake.

The Wetland channels are designed to operate in a plugflow character. Sets of two channels receive flow from a preceding pair as the wastewater flows through the 10 channel lengths. Each channel is 300 m long by  $\pm$  5 m wide (maximum available water surface). The HRT of the order of 6 - 12 hours through individual channels, and 2.5 - 5 days through the total system, dependent upon water depth in the channel and inflow volumes (Figure 7).

### 7.2.2 Wastewater Treatment Performance

Hydraulic loading to the channels has been found to range between 1 500-2 800 m<sup>3</sup>/d, which represents an areal loading of 100-180 l/m<sup>2</sup>/d, for the total available Wetland surface area, as compared to the area available in individual channels through which all the flow must pass.

The channel Wetland arrangement had been intended to assist in P removal. However, plant uptake capacity has been unable to achieve significant P removal at the hydraulic, and associated nutrient loadings, to which the system has been exposed. Additionally, P removal by plant assimilation requires regular harvesting of the plant to prevent re-release of P during plant senescence. In the absence of harvesting of the plants in the flow path, as compared to the plants on the embankment, management of P removal has also been restricted. It is also apparent that the surface flow configuration limits contact opportunity between wastewater and sediment by which physico-chemical P removal could be achieved.

Table 13 illustrates performance of the Wetland over a period of 2 years. All concentrations with the exception of E.Coli comply with General Standard requirements. Reductions were 75% for Suspended Solids, with COD, NH<sub>3</sub> and NO<sub>3</sub> approximating 50% and a  $\pm 10^3$  reduction in E. Coli. Ammonia removal rate ranges from 0.2 - 0.7g/m<sup>2</sup>/d, nitrate removal rate 0.5 - 1.5 g/m<sup>2</sup>/d, COD removal 2 - 4 g/m<sup>2</sup>/d, SS removal 0.2 - 2 g/m<sup>2</sup>/d.

**Table 13. Treatment Performance Of Lethabile Constructed Wetland Systems Over 2 year Period**

Determinant (mg/l unless stated)	Influent	Outflow
pH	7.5	7.65
NH <sub>3</sub> -N	8.2	3.2
PO <sub>4</sub> -P	7.9	6.8
NO <sub>3</sub> -N	34.0	15.6
COD	109	51.0
SS	24	4.4
Ec mS/m	117	108
TKN	8.4	8.1
E.Coli/100 ml	125 000	195

To illustrate the variable N removal capacity, Table 14 and 15 illustrate performance for individual channels through the flow of the system as determined by sampling at the end of each channel. These tables are also presented to also illustrate the apparent effect of influent N content on removal potential by comparing a medium or high ammonia concentration. The system is capable of achieving good nitrogen removal, nitrification and denitrification, with concomitant reduction in COD and SS. The relatively low overall removal rates are related to the fact that the maximum channel surface area available was not being fully utilised due to the prevalence of short-circuiting of the flow path, and the fact that greater removal is actually being achieved with individual channels than is apparent from assessment of the total system.

**Table 14. Treatment Performance of Lethabile Constructed Wetland System Medium Influent NH<sub>3</sub>-N (mg/l)**

Channel	In	1	2	3	4	5	6
NH <sub>3</sub>	18.5	13	6.3	1.0	2.5	1.5	1.5
PO <sub>4</sub>	11	11	12	11	12	11	11
NO <sub>3</sub>	43	33	24	14	14	8.0	4.0
COD	55	44	35	35	10	10	5
SS	25	30	1	2	1	3	1

**Table 15. Treatment Performance of Lethabile Constructed Wetland System High Influent NH<sub>3</sub>-N (mg/l)**

Channel	In	1	2	3	4	5	6
NH <sub>3</sub>	48	50	46	38	27	11	2.2
PO <sub>4</sub>	9.8	12	13	13	12	10	10
NO <sub>3</sub>	-	-	0.5	1.5	2.7	6.2	0.5
COD	110	84	70	84	79	59	35
SS	37	38	16	17	8	7	1

It is also apparent that, besides N removal capacity, the relative removal rate for all constituents in the secondary effluent, appears to increase with increasing influent concentration. This can be considered to be related to the greater availability of the constituent to the resident plant and microbial community.

Although Table 14 and 15 are presented it cannot be assumed that the system is accurately represented by sampling at the intermediate points in the flow path. The mechanical system has been prone to regular failure with the consequence that partially treated sewage is discharged directly into the Wetland which has detrimentally affected treatment performance, and largely been responsible for the presence of residual E. Coli. Consequently, a number of monitoring occasions detected variable quality between the sample points, related to the operation of the total system including pumped recycle between the oxidation ponds and the biofilter. As with Mpophomeni, despite nitrification occurring, pH and alkalinity were not reduced, confirming Wetland systems can have high inherent buffering capacity. Again, no significant influence of temperature or growth condition of the plant community has been identified at Letlhabile.

### 7.2.3 Hydraulic Characteristics

Tracer studies demonstrated significant internal mixing and dilution within the channel flow, and that plug-flow is not attained in practice. The dye was initially observed to emerge at a time equivalent to < 50% of the calculated HRT, to peak within a further 2 hour period and continue to appear up to 6-12 hours after introduction. It was clearly evident that water depth within the channel affected the apparent HRT as a shallow water depth allowed greater preferential flow and short-circuiting, whilst a deeper water level provided greater mixing and dilution. The flow path of the dye also illustrated preferential flow paths through the vegetation stands and within open water. The dye predominantly flowing along the middle of open water areas and to a lesser extent along edges. Open water areas have a limited hydraulic resistance, other than the influences of variations in the depth across the channel, and should nominally demonstrate laminar flow characteristics. In contrast, passage through the dense reed areas significantly affects the flow pattern and create turbulent flow.

### 7.2.4 Solids Accumulation

Letlhabile has suffered mechanical plant failures associated with the Biofilter feed pumps and Oxidation Pond recycle pumps. This has caused partially treated wastewaters to be by-passed directly into the Wetland system. In addition to the greater solids loads, these greater nutrient loads stimulates plant and microbial propagation within the channels, and subsequent deposition as sludge and sediment as these plants and microbes subsequently die-off. Operated as a meandering channel system, the primary pair of channels have been subjected to the higher relative organic and suspended solids loads. This has resulted in significant amount of solids being deposited, which affects the hydraulics and overall treatment potential.

The regular access of domestic animals (including goats and cattle), and rush harvesting has also caused some damage to the sandy embankments and channel floors with consequent erosion into the channels water area, further affecting available flow paths, and thereby treatment potential.

### 7.2.5 Vegetation Development

Sedges were planted on the channel embankments for harvesting and use in craft work, and continue to dominate the embankments despite the occasional harvesting and cropping by domestic animals. *Typha* communities occupy the majority of the internal channel and a lesser proportion of the embankments. *Frogmouths* is predominantly located in the lower channels and accounting for  $\pm 15\%$  of the total reed growth.

Extraction of samples of the reed materials from within the surface water flow areas has indicated that the root penetration of the reeds into the channel base has been primarily restricted to the  $< 200$  mm, and primarily into the light sediment depth of the base surface layer of the channel. More prolific has been the growth of the reed roots in the water layer such that the shallow surface waters are not predominantly occupied by scarce stem and leaf structures but by a dense, hydroponic, root matrix through which the wastewater should percolate, and thereby improve treatment potential.

### 7.2.6 Management

Weirs between the channels allow the water level to be raised or lowered for maintenance purposes in the individual channels. The overall HRT can be maintained by balancing the water levels in preceding or subsequent channels. In the event that partially treated wastewater is introduced, the HRT can be extended by raising the weirs.

Occasional introduction of partially treated sewage directly to the Wetland system during bypass conditions, and the degrading plant, sludges and sediments, does encourage development of excessive levels of mosquito and associated nuisance insects. The operators are advised to raise the water level in the channels for several days when mosquito larvae become excessive, to drown the larvae prior to returning the water level to its operational position.

The operators have been advised to attempt to maintain an open water channel through the system which has resulted in the occasional manual removal of *Typha* from the channels. However, this limited activity is rapidly counter-acted by the regrowth of the *Typha* within the channels and appears to have little direct benefit.

### 7.2.7 Management Recommendations

- 1) Clear Wetland channels and rehabilitate channel embankments and floors.
- 2) Maintain inlet and outlet sumps clear of vegetation and accumulating sediments.
- 3) Rehabilitate weir structures and valves
- 4) Monitor inflow volume and presence of by-pass wastewaters to the primary channel on a daily basis and adjust outlet weir level accordingly to provide required flow balancing and extended HRT.
- 5) Monitor weir settlings of each pair of channels on a daily basis, and adjust accordingly to ensure balanced and controlled HRT through the total system
- 6) Plan and schedule regular mosquito control exercises.
- 7) Organise and control 'harvesting' and 'cropping' exercises to minimise detrimental impact of such operations on channel integrity. If possible provide a dedicated channel, or new open 'marsh' area where sedges and/or rushes can be specifically cultivated rather than interfering with a wastewater treatment system component.
- 8) Maintain channel embankments clear of excessive grass and weed encroachment as a fire control management practise.
- 9) Drain channels down on a monthly basis to assist in the redistribution of solids matter accumulating within the primary channels, and to deter preferential flow paths from becoming rigidly established in any of the channels.
- 10) Ensure the final channel has a well established reed development to assist in the removal of algae and lemna etc that will develop in preceding open water areas.
- 11) Introduce fish to the channels to assist in insect control.
- 12) Introduce channel dividers (nominally 200 mm tall) across the width of the channels at  $\pm 30$  m intervals to assist in maintaining channel hydraulics and isolating sediment passage, whilst providing a reasonable minimum water depth for operational control.

## 7.3 LADYBRAND

### 7.3.1 System Configuration

Ladybrand is a predominantly rural community in the Free State, for which the sewage treatment system has been constructed as an intermediate approach to wastewater treatment, comprising pond and mechanical components. After coarse screening the sewage is discharged to anaerobic ponds followed by aerated facultative ponds, passive facultative ponds and final polishing and treatment through two Constructed Wetland units. The maximum design capacity is estimated at 4 500 m<sup>3</sup>/d, although average flows of the order of 1 600 m<sup>3</sup>/d have been recorded during the investigation periods (Figures 8 and 9).

The Wetlands are operated as vertical flow gravel bed systems, ostensibly for the polishing of the algal solids generated in the facultative ponds and residual nutrients and pathogens. The media is a graded fine gravel ( $\pm 6$  mm) of 300 mm depth overlying a 150 mm coarse gravel ( $\pm 19$  mm) base layer, and planted with *Typha*. The effluent from the facultative pond is introduced to the Wetland through 3 concrete inlet channels per bed, in a controlled manner to maintain a water depth of  $\pm 500$  mm, filtering downwards through the gravel to be collected in a drainage network to be drawn off through 3 sets of outlet weir per bed connected to the underdrain system. The outlets are located on the opposite side to the inlets and lead to maturation ponds and chlorination prior to release to the water course.

### 7.3.2 Wastewater Treatment Performance

The combination of anaerobic ponds and the aerated lagoons achieve a high degree of organic load reduction, whilst the bacterial solids carried from the aerated lagoons appear to settle readily in the facultative ponds. The residual organic and the nutrient load passing into the facultative ponds encourages development of high populations of algae which is then subsequently loaded onto the Wetland surface for removal.

Table 16 illustrates the average performance achieved by the Wetland cells. Table 17 indicates spot sampling of individual Wetland outlet points, and Table 18 microbiological quality of the individual Wetland outlet points.



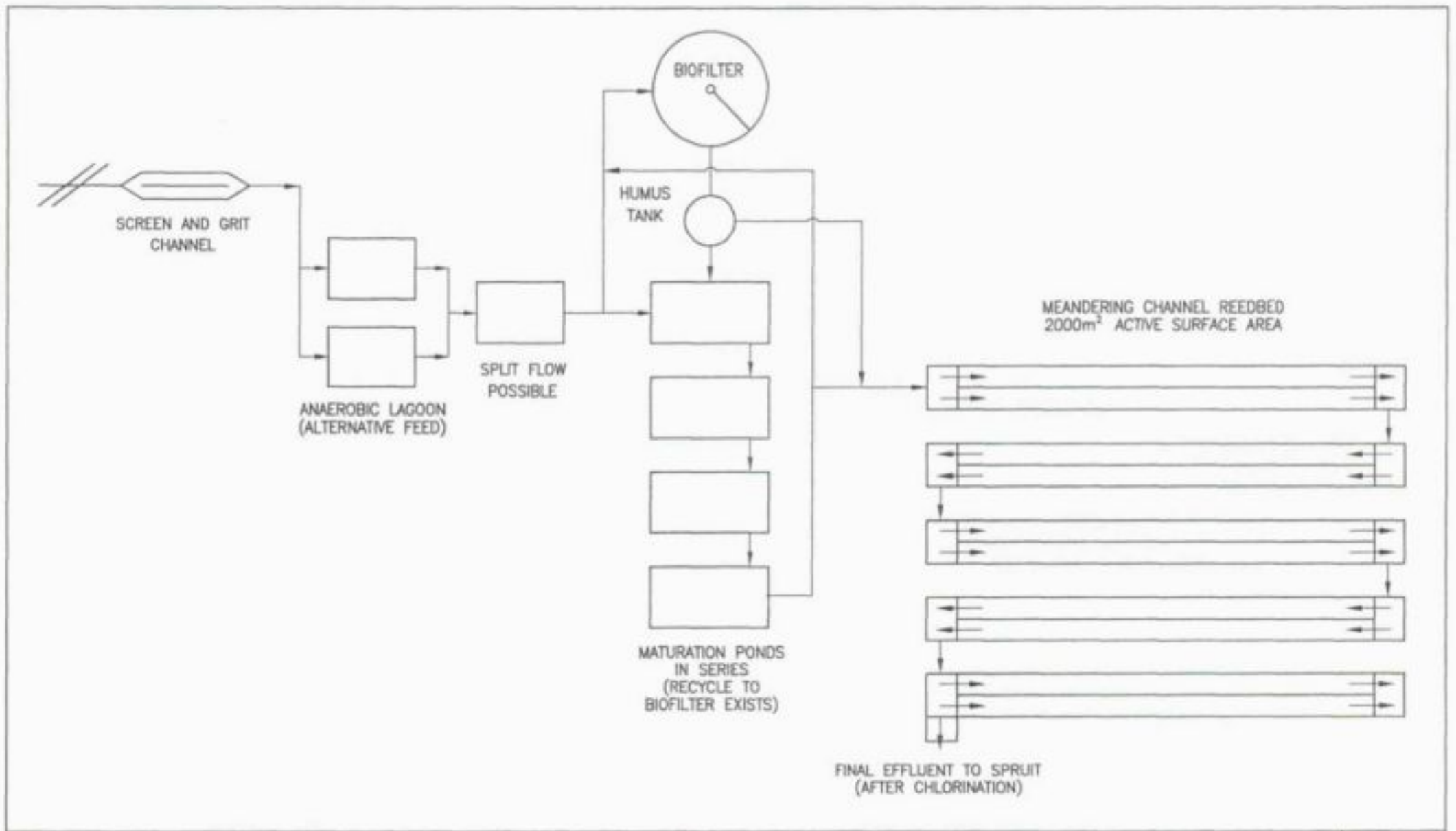

LETHLABILE  
SEWAGE TREATMENT AND CONSTRUCTED WETLAND SYSTEM (CONCEPTUAL - NOT FULL ARRANGEMENT)

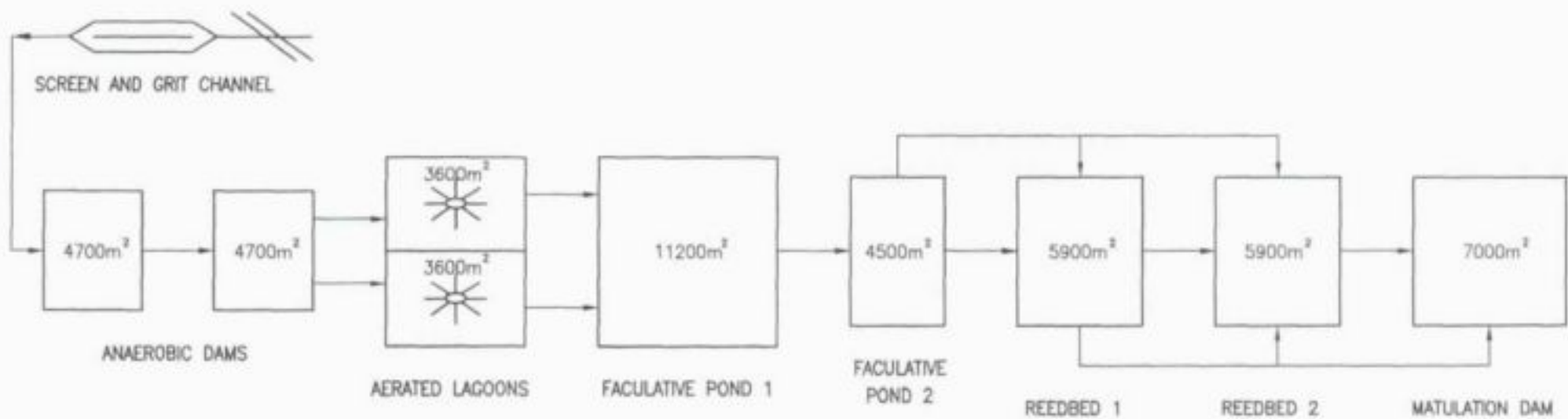

DESIGN CAPACITY = 4,2 Ml/d

LADYBRAND  
SEWAGE TREATMENT AND CONSTRUCTED WETLAND SYSTEM - SCHEMATICS

**Table 16. Performance of Ladybrand Constructed Wetland System**

Determinant	Inflow	Outflow
pH	7.0	7.2
TDS	790	795
OA	15	12
COD	162	115
NH <sub>4</sub>	54	48
NO <sub>3</sub>	0.7	0.6
NO <sub>2</sub>	0.04	0.03
PO <sub>4</sub>	17.4	17.8

**Table 17. Spot Sampling of Individual Wetland Cell Outlet Pointso of Ladybrand Constructed Wetland System**

	Inflow	1	2	3	4	5	6
NH <sub>4</sub> -N	44	51	36	40	36	30	30
PO <sub>4</sub> -P	14	11	11	15	11	13	14
NO <sub>3</sub> -N	0.9	0.2	0.3	0.2	0.0	0.1	0.1
Kj-N	52	48	45	48	40	38	37
TP	14	13	13	17	14	17	18
COD	162	92	80	66	80	86	78
SS	120	24	16	28	12	14	22

**Table 18. Microbiological Quality of Individual Wetland Cell Outlet Points of Ladybrand Constructed Wetland System**

	Inflow	1	2	3	4	5	6
E.Coli	6 700	3 000	3 900	2 400	500	300	5 000
T.Coli	10 <sup>5</sup>	11 000	23 000	4 000	3 000	5 000	7 000

E.Coli/100ml. T.Coli = Coliforms/100ml

It is evident that although a significant amount of algal suspended solids is being removed by the Wetlands, what may be considered excessive levels are still present in the outflows, and the overall nutrient removal is limited, with a maximum  $\text{NH}_3\text{-N}$  and  $\text{PO}_4\text{-P}$  removal of 30%, with in many cases the outlet quality actually approximating the influent quality.

As with the Mpophomeni Wetland the potential to remove N as the wastewater percolates through the bed is significantly limited by the ability to provide oxygen into the rootzone for nitrification. Whereas denitrification would be expected to be enhanced in the anoxic conditions within the bed where carbon would be readily available from the wastewater and degrading plant and algal components, the absence of influent nitrate masks any potential that would be available for nitrate removal capacity. The low nitrate effluent concentrations do suggest that any nitrification that has been possible within the bed has been subsequently denitrified and removed from the system. It is also considered that the degradation of algal cells and associated plant and microbial material within the Wetland will also contribute N to the water in a dissolved form which will further mask effective N removal potential when simply comparing wastewater inflow and outflow qualities.

COD removal has averaged about 50% corresponding to reductions in SS levels. This relatively low removal potential is considered to result from the availability of the wastewater to pass directly through the relatively coarse gravel media and thereby not be filtered and immobilised to the extent that is possible with fine sand or soil bed Wetlands. As to be discussed in the hydraulic characteristics, it is also apparent that severe short-circuiting occurs which allows relatively untreated wastewater to pass indirectly through the system. The difference in outflow pollutant concentration between individual outlets also reflects a level of preferential flow within the Wetland which allows some areas to receive greater HRT, and thereby opportunity for treatment.

Although some pathogen removal is evident as the wastewater passes through the Wetland it is relatively low at 90 to 99%, as a result of the short-circuiting occurring through the beds, the coarse nature of the gravel limiting filtration and immobilisation of pathogens, the relatively short HRT available for pathogen destruction, and the cover of the Wetland limiting exposure of the flooded surface waters to UV irradiation to destroy pathogens.

### 7.3.3 Hydraulic Characteristics

Despite the provision of a defined gravel media, a relatively shallow flowpath through the gravel to the drainage layer, and the vertical flow path as opposed to horizontal, there does appear to be a hydraulic constraint to the effective performance of the Wetlands. This is confirmed by monitoring exercises of the outflow volumes from each of the drainage points which demonstrated that, despite nominally equally set levels, there was a 4 times difference

in outflow volume between individual outlets, and a difference between the two beds of  $\pm 40\%$ .

While an HRT of  $\pm 144$  hours is calculated for the flows of 1 600 m<sup>3</sup>/d and a bed surface area of 12 000 m<sup>2</sup>, tracer studies demonstrated the appearance of the dye within 1 hour, indicating minimal mixing and diffusion has occurred. Adding the dye to the middle inflow point of the Wetland cell resulted in visible channelling across the bed surface. The bulk of the dye appeared at the corresponding outlet channel with some limited diffusion into the side channels over the period of the discharge of dye, and only traces of dye remaining after 48 hours.

The implication from these results is that rather than the flow being equally distributed across the full Wetland surface area, the system is dominated by short-circuiting and preferential flow paths developed directly between the influent and effluent points. It is apparent that the wastewater, although introduced at three inlets on one side of the bed does not readily spread across the whole bed surface but predominantly short-circuits directly from the inlet down into the underdrain and away to the outlet. This extreme level of short-circuiting significantly reduces the effective HRT by at least 10 times and accounts for some of the poor treatment performance experienced.

#### 7.3.4 Surface Solids Accumulation

There has been an amount of sediment accumulation on the surface of the Wetland which affects the percolation of the inflow vertically into the gravel media by acting as a localised resistance layer. The sediment layer has arisen from solids carried over from the facultative ponds, as well as the inherent production of plant material which is released into the system upon the seasonal senescence, which again has tended to accumulate in quiescent zones on the Wetland surfaces.

The accumulation of sediment is most pronounced at the inlet side whether sediment brought in would have the opportunity to settle and deposit as it filtered through the vegetation matrix to distribute water over the bed surface area. It is also evident however, that there are differences in the level and position of sediment deposition across the bed surface which appear to have resulted for the preferential flow paths as the water percolates around dense clumps of reed and seeks the path of least resistance.

#### 7.3.5 Vegetation Development

Although the Wetland cells give the appearance of being a dense stand of *Typha*, with which the Wetland was initially planted, during winter senescence periods where the vegetation was burnt to clear the surface, it has become apparent that there have remained patchworks of localised dense *Typha* growth interspersed with open water areas and channels. The spread of

individual clumps of *Typha* from the initial planting, rather than the extension of radial roots from which new clumps develop, as is common with *Frogmouths* growth in Wetlands. The localised growth of the *Typha* significantly affects the ability to encourage contact with the wastewater and to enhance filtration and minimise short-circuiting and preferential flow paths around the clumps rather than physically through them.

When the surface is exposed after burning events, the surface water supports *lemna* and algae transferred from the Facultative ponds. Very little evidence of other reeds species such as *Frogmouths*, sedges or rushes has occurred through natural establishment, and grasses are primarily restricted to the drier edges of the bed and in some open areas within the bed.

Excavation of *Typha* clumps also indicated the relatively limited root development within the vertical profile of the bed, with very little root extension below 200 mm. As the majority of the bed depth is root free the presence of the plants has little impact upon the ability to create aerobic and nitrification conditions within the depth of the bed, leaving the bed to primarily function as a coarse gravel filter.

### 7.3.6 Management

Weirs on each of the outlet channels allow the water level to be raised or lowered for maintenance purposes in the individual beds, and theoretically to control flow across the bed width. The overall HRT can be maintained by balancing the water levels on the beds. In the event that sediment accumulation inhibits permeation potential the hydraulic head can be increased by raising the outlet weirs. The provision of weirs in the individual inlet channels should also allow control of the relative flow introduced to each bed, and to the individual areas within each bed.

As the Wetlands are operated in a flooded manner it is not readily possible to get into the beds to physically harvest the reeds, although a by-pass facility is possible reasonably easy with the Ladybrand system. Consequently, the primary management tool to control the plant development has been to burn reeds back during the winter. Although this is considered to assist in promoting the better development of the reed community in the following season it does not remove the plant material in the flooded zone and may still result in the release of plant nutrient material into the Wetland.

Unlike the Letlhabile sewage treatment plant which has had up to 12 operators and labourers on-site and technical support available from the local authority 2 km away, and Mpophomeni which has up to 6 operators, the Ladybrand sewage works generally only has 1 labourer on-site whose primary function is to keep the screen clean, with occasional visits from supervisors and maintenance services. However, it would appear that little attention is paid to the specific management of the Wetland units, which are located some distance from the screen and grit

channels, and these have largely been left to operate unassisted. Although, this should not normally represent a problem, Wetland units do require a level of management to ensure that the system has a chance of performing to its optimum, and that any problems that do develop are addressed timeously.

### 7.3.7 Management Recommendations

- 1) Monitor inflow level settings of each Wetland on a daily basis, and adjust accordingly to ensure wastewater is evenly distributed between the two beds, and the individual inlet points of each bed.
- 2) Monitor outflow level settings of each Wetland on a daily basis, and adjust accordingly to ensure wastewater is evenly distributed through the outlet drains.
- 3) Maintain Wetland inlet and outlet zones and system surrounds clear of excessive grass and weed encroachment.
- 4) Flush subsurface drains regularly ie at least monthly, to remove accumulate solids blocking drain inlet points. This can be undertaken by shutting off one Wetland inflows to increase the hydraulic loading to flush through the one pipeline being cleared at a time. Draining the unfed bed should also assist maintaining the drain in an open condition.
- 5) Install surface barriers across the Wetland width to encourage wastewater to percolate into the front sections of the Wetland and limit short-circuiting direct to the outlet zone, and the ensure that a nominally even flow is provided across the whole bed inlet zone.
- 6) Clear inlet zone of excessive surface solids and surface slimes accumulation during drainage exercises.
- 7) Operation of the Wetlands alternately in a fill & draw mode to enhance aeration of the wastewater as it transfers through the gravel Wetland, encouraging the development of heterotrophic bacteria upon the gravel media to assist in algae solids immobilisation, as hydraulic load permits.

## 7.4 BETHLEHEM

### 7.4.1 System Configuration

Bethlehem is also a predominantly rural town in the Northern Free State, although it has a greater commercial activity than Ladybrand. As a result of a concern over final effluent quality, and particularly phosphate levels, produced by a series of conventional maturation ponds receiving effluent at up to 4 500 m<sup>3</sup>/d from combination Biological Filter and Activated Sludge system at Bethlehem the maturation ponds were converted into Constructed Wetlands.

Five maturation ponds, with a total surface area of  $\pm 2$  ha, were cleared and a media of coarse rock from a decommissioned Biological Filter and/or railway ash was installed, prior to planting with *Frogmouths* obtained from an adjacent natural Wetland area. The beds operate as horizontal flow subsurface units with a general slope of the Wetland bottom of  $\pm 1\%$  between the inlet and outlet. The inlet depth is  $\pm 600$  mm and the outlet  $\pm 1\ 000$  mm. Beds 1 to 3 have a surface area of  $\pm 2\ 400$  m<sup>2</sup> each, bed 4 is 5 600 m<sup>2</sup> and bed 5 is 5 500 m<sup>2</sup>.

The Wetlands are operated in parallel. The effluent being discharged from the individual control sumps to a chlorination contact channel before discharge to the Spruit. The inlet consist of a single 150 mm cast-iron pipe laid across the bed width and connected into the main wastewater pipe system from a single, nominally mid-point T-junction. At  $\pm 300$  mm intervals the pipe has  $\pm 10$  mm holes drilled into it at approximately the mid level of the pipe. The inlet distribution pipe is then covered with a layer of gravel. The effluent is drawn from the bottom of the outlet zone, again via perforated piping leading to the individual outlet sumps where the water level can be adjusted as required (Figure 10).

### 7.4.2 Wastewater Treatment Performance

Although the system was designed to accommodate up to 4 500 m<sup>3</sup>/d the loading to individual beds has been erratic, from initially a few hundred m<sup>3</sup>/d to assist establishment, to 2 000 m<sup>3</sup>/d through bed 5 alone, in receiving the majority of the flow through the works.

Table 9 illustrates performance for the system over a two year period. Table 20 illustrates the outlet PO<sub>4</sub>-P concentration relative to flow for each bed. Given the high quality of the influent wastewater the potential for further improvement in quality is limited, and only a  $\pm 40\%$  reduction in COD is achieved and  $\pm 50\%$  NH<sub>3</sub>-N, NO<sub>3</sub>-N and SS.



**Table 19. Performance of Bethlehem Constructed Wetland System (Combined Effluent From Beds 1-5)**

Determinant	Inflow	Combined Outflow
pH	7.6	7.81
OA	7.4	5.3
COD	55	34
NH <sub>3</sub> -N	3.6	1.9
NO <sub>2</sub> -N	6.2	3.2
NO <sub>3</sub> -N	0.2	0.15
SS	18	7.0
PO <sub>4</sub> -P	2.0	1.9

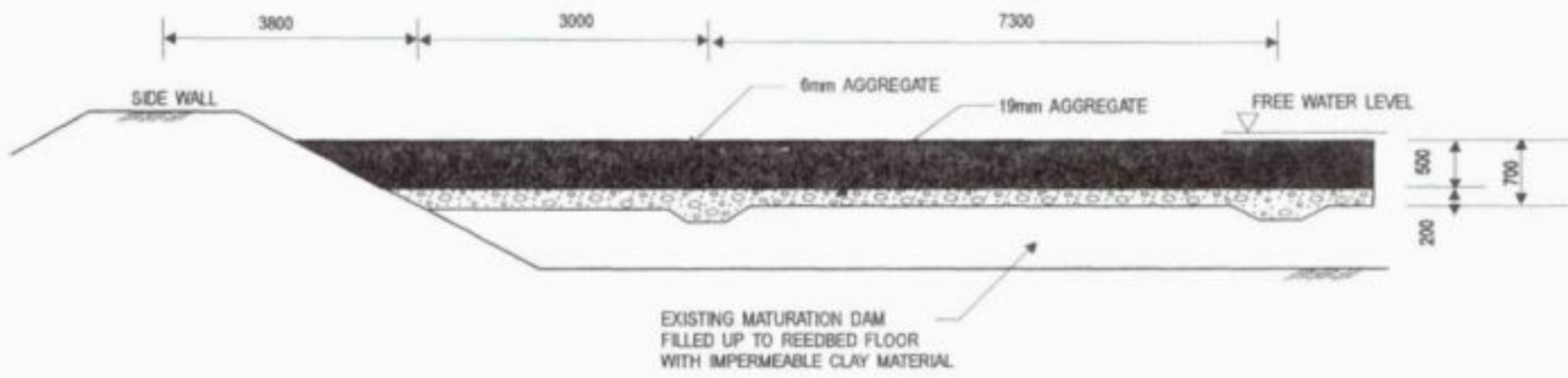

LADYBRAND  
 CONSTRUCTED WETLAND CROSS-SECTION

TOTAL POTENTIAL FLOW  
FROM BIOFILTERS = 4500m<sup>3</sup>/DAY  
TOTAL AREA = 18300 m<sup>2</sup>



BETHLEHEM CONSTRUCTED WETLAND

**Table 20. Bethlehem Constructed Wetland Outlet PO<sub>4</sub>-P and Flow Volume Compared to Inflow PO<sub>4</sub>-P**

IN PO <sub>4</sub>	1		2		3		4		5	
	PO <sub>4</sub>	m <sup>3</sup>	PO <sub>4</sub>	m <sup>3</sup>	PO <sub>4</sub>	m <sup>3</sup>	PO <sub>4</sub>	m <sup>3</sup>	PO <sub>4</sub>	m <sup>3</sup>
2.43	1.13	85	1.05	108	0.74	94	1.13	26	1.33	-
> 5.0	1.09	248	1.06	252	0.58	172	1.13	421	1.05	-
1.40	1.06	30	1.01	34	0.66	55	1.22	143	1.48	115
2.07	1.17	203	1.03	89	1.13	236	1.48	115	1.22	115
2.04	1.16	82	0.9	143	0.9	-	1.18	40	1.39	431
1.93	1.14	14	1.39	34	0.74	61	1.4	56	1.32	71
1.43	0.71	169	0.41	200	0.48	309	0.43	120	0.62	120
2.25	1.13	47	1.31	107	1.10	89	1.41	213	1.56	110
1.16	1.17	69	1.11	305	0.93	190	1.04	153	1.02	145
2.67	1.21	218	1.15	8	1.1	1	1.27	1 855	1.43	-

**Table 21. Microbiological Analysis of Bethlehem Constructed Wetlands**

	E.Coli	Coliforms
Inflow	160 000	1 200 000
Outflow Bed 1	3 300	20 000
Outflow Bed 3	2 000	6 000
Outflow Bed 4	3 100	19 000
Outflow Bed 5	6 700	21

Limited removal in COD is believed to be a result of non-readily biodegradable organic remaining after pretreatment through the Biofilters and Activated Sludge systems. The Wetlands are not expected to address such components given the coarse nature of the bed media and limited contact with the resident microbial and plant matrixes. Even in the beds with waste ash, residual COD is detected indicating that this is not readily adsorbed and retained within the bed. Residual COD may also be derived from plant material during senescence periods.

Low NH<sub>3</sub>-N removal is primarily related to the limited oxygenation capacity of the system and generally low influent concentrations limiting development of viable nitrification communities. NO<sub>3</sub>-N removal is limited by the availability of readily biodegradable organic carbon as energy source for the bacteria, in the absence of organic stores within the media of gravel and ash, as compared to soil.

Although some enhanced  $\text{PO}_4\text{-P}$  removal is indicated for the beds incorporating waste ash, it is considered minimal and subsequent to the first two years of operation the benefits of incorporating the waste ash are not apparent. The implication from this observation is that the  $\text{PO}_4\text{-P}$  adsorption potential of the waste ash has become saturated, although the generally poor  $\text{PO}_4\text{-P}$  removal from the start indicates the initial capacity was also limited. It may also be taken to suggest that preferential flow paths developed through the ash bed may have mitigated against the full phosphate adsorption potential being utilised.

Table 21 illustrates Microbiological quality where the individual beds achieve  $\pm 99\%$  reduction in *E. coli* and  $\pm 99.9\%$  removal of Total Coliforms. The lack of difference between the bed performance again suggests the ash bed, which may have been expected to have a greater pathogen removal, is performing no better than completely gravel beds.

### 7.4.3 Hydraulic Characteristics

A primary factor limiting wastewater treatment capacity is the poor hydraulic control through the beds and tendency for short-circuiting between inlet and outlet. Despite a projected HRT of the order of 20-24 hours, tracers studies demonstrated the dye emerging within 1 hour, to peak within a 2 hour period, but continue to appear up to 48 hours after initial introduction.

The path of the dye upon its introduction into the bed illustrated a dominant flow path across the surface of the inlet zone prior to descending into the bed media. The dye was also observed to travel along the edges of the bed directly between the inlet and the outflow sump where surface ponding provides a zone of lower resistance to flow than the media itself. The tracer studies illustrated the Wetlands do not operate in a distinct plug flow mode, but that there is internal mixing, diffusion and retention in the path between input and output.

The predominantly very coarse gravel (> 50 mm diameter having come from obsolete Biological Trickling Filters) used as the bulk of the media, supplemented with railway ash ensures a relatively good permeability. Exercises to assess the void volumes by filling and draining beds, indicated void volume of the order of 30-50% of the bed volume. More importantly, the rate of the decline, and subsequent rise in water depth, through the bed during such exercises identified significant hydraulic gradients exist. Water 'mounding' was clearly evident during such exercises as there was a definite surge which takes several minutes to be transferred to the inlet zone as the outlet valves are initially fully opened, and subsequently closed. Collection of outflow to a single point in one corner of each bed also encourages a gradient to be generated in the horizontal profile across the bed. The water from the proximity of the drain outlet will be preferentially drawn through the outlet and water from the further zones of the bed remain static and drawdown in the vertical profile.

Hydraulic loading experiments demonstrated that the gravel beds can accommodate loadings of up to 500 mm/d without undue surface flooding, by maintaining the outlet discharge at a

low level and providing an acceptable hydraulic lead through the bed length. However, at a surface loading of 250 mm/d the combined ash/gravel bed demonstrated more significant ponding even where an equivalent hydraulic gradient is provided.

#### 7.4.4 Solids Accumulation

Surface blinding of the inlet zones appears to be a result of solids carried from the humus tanks, some growth of microbial and slimes mass, and deposition of plant litter. The surface of the beds appears relatively clear from  $\pm 2$  metres from the inlet zone. When the beds are operated at a low hydraulic load infiltration of the wastewater into the bed system occurs. However, where excessive hydraulic loads occur slimes and sediments are carried further across the bed surface inhibiting the vertical percolation of the wastewater, and causing localised ponding, and channelling along the bed sides and direct to the outlet zones.

Dye studies also identified the inability of the inlet pipe to maintain an even distribution across the full bed width due to the fact that the inlet pipes were no longer lying level, that a number of the outlet holes were not discharging wastewater, and that wastewater was not being evenly distributed across the bed width as intended. Uncovering the inlet pipe revealed that many distribution holes had become blocked with a mixture of sludge and leaves from within, and that the covering of gravel was, at many points, providing a barrier to release of the wastewater from the hole and further encouraging solids accumulation from within against the hole.

During hydraulic loading, and bed draining, exercises no significant amount of suspended solids were released, although there was a turbidity to the drainage water and an  $H_2S$  odour demonstrating that the water within the Wetland was predominantly anaerobic. Limited solids drawn through the bed during draining activities supports the contention that solids accumulation within the void volumes over time is limited. The solids within the bed predominantly undergoing degradation and stabilisation.

#### 7.4.5 Vegetation Development

The reed communities has developed to fully occupy the bed surface area of beds 1 to 3 which were intensively planted at construction, and no readily visible 'bald' patches are observed. Again it appears that the relatively low organic loadings, and beneficial climatic conditions, have permitted a proliferation of reeds. The low organic and hydraulic loadings will encourage a combined aerobic and anaerobic microbial community better stabilising the environment around the plant roots, the rhizosphere, and minimising the production of toxic anaerobic by-products, particularly  $H_2S$  and fatty acids. Beds 4 and 5 which were not fully planted initially still remain relatively sparsely populated, although many new shoots are visible spreading horizontally from existing established reeds.

A problem with beds 4 and 5 has been that rather than *Frogmouths* as planted into beds 1 to 3, *Arundo donax* were planted into beds 4 and 5. The root systems of this grass have not extended more than  $\pm 200$  mm in depth, limiting the viable depth of the rootzone through which the wastewater percolates, and inherently encouraging the wastewater to pass under the rootzone in predominantly anaerobic conditions.

Although shallow root growth is expected for grass species such as *Arundo donax*, the conventional rootzone reedbed concept assumes that roots will penetrate to occupy, and aerate, the whole bed volume. However, excavations in both the ash and gravel beds also indicated that the *Frogmouths* and *Typha* root growth was also limited to the top  $\pm 200$  mm with very little penetration to any further depth despite  $> 5$  years of growth. The denser ash media appearing to inhibit the effective of root development more than the coarse gravel.

#### 7.4.6 Management

Each bed inlet sump is provided with valving to control the individual bed inflow. The outlet sumps are provided with standpipes and three valves which enables the water depth within each of the Wetlands to be independently controlled. Under normal operational conditions the water is maintained at the upper discharge level to optimise HRT through the system. On a regular basis the water levels are dropped to allow the inlet and outlet zones to be cleared of excess weed growth encroaching from the embankments, and control of mosquito and other insect life which otherwise proliferate in ponded areas.

Little attention appears to have been given to ensuring that inflow to each of the beds is appropriately monitored and controlled. Each bed has received variable loading, with the majority of the wastewater by-passing beds 1 to 3 and being released into beds 4 and 5. An implication is that, in providing a gravity feed system to a number of Wetland units in series, it is necessary to maintain control of the individual flows to prevent overloading or underloading of individual beds.

Another valuable observation from the Bethlehem systems is the necessity to operate the outlet drain discharge level to control the water level within the beds at a subsurface position. Adjusting the valve allows the control of the hydraulic head through the bed and to the outlet, but only when effectively managed.

#### 7.4.7 Management Recommendations

- 1) Monitor inflow volume to each Wetland on a daily basis and adjusted accordingly to provide each bed with a comparable loading.
- 2) Monitor outflow valve settings of each Wetland on a daily basis, and adjust accordingly to ensure water does not pond in the effluent zone and/or excessively flood the influent zones.

- 3) Maintain Wetland inlet and outlet zones and system surrounds clear of excessive grass and weed encroachment.
- 4) Flush inlet distribution pipelines regularly ie at least monthly, to remove accumulate solids blocking outlets points. This can easily undertaken by shutting off all other Wetland inflows to cause all wastewater to flush through the one pipeline being cleared at a time.
- 5) Monitor inflow distribution across the bed width to ensure that the inlet pipe system is appropriately levelled and that a nominally even flow is provided across the whole bed inlet zone.
- 6) Clear gravel and associated vegetation from around the influent pipe distribution nozzles and allow wastewater to flow freely onto the inlet zone.
- 7) Replace *Arundo donax* (Spanish Grass) in beds 4 & 5 with *Frogmouths* reed as possible.
- 8) Replace inlet flow metres as possible.
- 9) Drain beds down on a monthly basis to assist in the redistribution of solids matter accumulating within the bed, and particularly from the inlet zone, and to introduce aeration to the lower bed levels.
- 10) Clear inlet zone of excessive surface solids and surface slimes accumulation during drainage exercises.
- 11) Operation of the Wetlands with the outlet drain position set at a mid-point level to enhance aeration of the wastewater as it transfers through the upper levels of the Wetland, as hydraulic load permits.

## 7.5 KRUGER NATIONAL PARK

### 7.5.1 System Configuration

The Kruger National Park has adopted the Wetland technology for the treatment of the wastewaters generated by the camps throughout the Park. The larger camps, such as Lethaba, Olifants, and Skukuza were initially provided with conventional Oxidation Pond systems, whilst the smaller camps of Crocodile Bridge and Shingwedzi were identified as suitable for Constructed Wetlands at a time when the Wetland technology in South Africa was just being introduced in the late 1980's. During 1992-93 the Park installed Wetland systems at each of their camps either to polish pond effluent or to treat the septic tank effluent directly. There are presently 17 systems in operation



The Wetland units generally follow a common format, being designed to accommodate the maximum possible number of visitors that are to be accommodated at the camp at any one time, and then providing an additional contingency of  $\pm 25\%$  to account for limitations in the knowledge of the technology and the desire to be conservative rather than risk further problems. Additional contingency is built into the hydraulic capacity of the beds in that the media depth has been set at 1 000 mm, rather than the generally accepted depth of 600 mm for Rootzone systems, but less than the Mpophomeni bed depth of 1 500 mm which was used as an example of the technology at the time of the initial interest in the approach.

The Wetland systems also generally consist of two beds of river sand operated in series to ensure adequate organic load capacity and disposal of effluent via evaporation and infiltration from the bed rather than unnecessary discharge to the local rivers, which would inherently attract wildlife to the discharge which is also undesirable.

### 7.5.2 Wastewater Treatment Performance

Table 22 illustrates the performance of 3 Kruger Park constructed wetland systems receiving septic tank effluent. The Crocodile Wetland indicates a better  $\text{PO}_4\text{-P}$  removal efficiency than the other systems which is believed to be a result of the greater  $\text{PO}_4\text{-P}$  adsorption potential of the sand media in this system, and partially the significantly denser vegetation development in the Crocodile system which has been in operation for > 7 years.

COD and SS removal has generally been as good as would be expected from basically sand filtration beds, but the presence of surface short-circuiting at Mobeni and Tshokwane, and containment of the effluent in the discharge sumps allowing algal and bacterial development, results in elevated effluent pollutant qualities.

$\text{NH}_3\text{-N}$  removal is limited by the ability of the nitrifying bacteria to compete for the available oxygen in the system. Although > 70% removal in  $\text{NH}_3\text{-N}$  is indicated for the Crocodile bridge system this is achieved at an HRT in excess of 5 days (assuming minimal short-circuiting potential). Each of the other sites where an effluent is being discharged from the primary Wetland demonstrate significantly poorer  $\text{NH}_3\text{-N}$  removal efficiency, generally < 25%. This poor performance is primarily related to poor vegetation development on the bed surface and the propensity to short-circuit.

Each of the Wetland, has a second Wetland cell to receive the overflow. Usually the discharges from the primary beds is adsorbed within the secondary beds and no final discharge occurs. Although this suggests the Wetlands designed are over-sized it is necessary to see this in respect of the greater desire to protect the receiving environment and not to produce a discharge stream which may attract wildlife to the sites with consequent impact upon the integrity of the site.

### 7.5.3 Crocodile Bridge Wetland System

The Crocodile Bridge Wetland system one of the two original Wetland units has received septic tank effluent for almost 7 years with little direct management other than occasional removal of excess above ground plant. The system consists of two beds of river sand operated in series of which only the first Wetland has to date been planted with *Frogmouths*. The second Wetland is to contain and polish discharges from the first Wetland prior to discharge to the Crocodile river.

**Table 22. Performance of 3 Kruger Park Constructed Wetland System Receiving Septic Tank Effluent**

	Crocodile Bridge	Crocodile Bridge	Mopani	Mopani	Shingwedzi	Shingwedzi
	In	Out	In	Out	In	Out
pH	7.55	7.25	7.3	7.65	6.9	7.15
TDS	787	748	929	1187	518	570
Ec	108	102	127	158	72	79
T.Alk	390	215	510	175	290	325
COD	166	23	142	35	135	30
OA	23	11	18	12	18	10
NH <sub>3</sub> -N	44	10.5	25	29.25	36	33
PO <sub>4</sub> -P	6.4	1.3	5.6	6.2	7.2	5.4
Ca	37	35	25	36	29	39
Mg	22	33	55	66	15	17
Na	105	105	121	204	46	66
Cl	90	99	105	138	31	34
SS	4	3	28	4	15	3.5

### 7.5.4 Hydraulic Characteristics

Based upon a projected HRT of the order of 72-96 hours, automatic samplers were only set to sample the discharged effluent over the first 48 hours to indicate any early break through and to provide an indication of the treatment performance, whilst visual observation by the plant supervisor over following days was undertaken to indicate the release of the dye and the extent of the discharge pattern.

The period over which dye emerged from the bed clearly illustrated that the Wetlands are not operating in a distinct plug flow mode, but that there is internal mixing, diffusion and retention in the path between input and output. The tracer studies also illustrate that if

practical hydraulics of small scale systems are not engineered correctly into larger systems the expected performance may be severely jeopardised.

Due to the density of the vegetation growth within the Wetland, and the apparent prevalence of snakes within the Wetland, it was not possible to enter the Wetland to assess the extent of surface ponding and the path of the dye into the bed itself. However, the absence of vegetation on the secondary bed did clearly illustrate that despite the relatively permeable sandy media, surface ponding readily occurs. Elevated organic load in the feed to the primary bed enhancing slime and bacterial development causes a significantly greater ponding effect at the inlet of the primary bed than observed in the secondary.

### 7.5.5 Vegetation Development

It was not easy to get into the Wetland centre to assess the root system development of the plants but individual examples of the Reed community dug out from the edge of the Wetland demonstrated that the root system which could be removed easily was relatively shallow ie the bulk of the root system was < 300 mm in length, indicating that the reeds are not actively extending their root systems in the vertical direction when water is relatively readily available to them, and the media itself provides resistance to penetration.

The depth of the Wetlands at  $\pm 1\ 000$  mm allows a substantial part of the bed volume, and the wastewater that occupies the voids, not to be in contact with the plant root system, and therefore available for biological and physico-chemical interactions with the plant system and the treatment potential that this offers. It is also possible that the presence of root material in the upper bed zones rather than enhancing permeability by opening up channels and providing channels through dead root systems, practically inhibits permeability in a sand material. Consequently, the path of least resistance through the bed may be through the root free zones of the lower bed and the bulk of the wastewater may not contact with the rootzone to any significant degree. Passage through a predominantly anaerobic subsurface and sub-rootzone system may be considered to account for the limited ammonia reduction achieved through the Wetlands, despite relatively extended HRT's and generally good COD reduction.

### 7.5.6 Management

Wastewater from septic tank and/or primary pond systems, is collected into a concrete sump from which a number of outlet pipes (usually 3) transfer the wastewater to the discharge points across the inlet of the Wetland. Since the pipework to the inlet points is buried, it is not possible to adjust the levels of the pipes to ensure an even distribution of wastewater to each section of the inlet zone. At the relatively low flows to which the Wetlands are generally subjected, a difference of 1 or 2 mm in collection or discharge level has a significant impact upon the distribution of the wastewater to the inlet zone.

A limited number of inlet positions across the width of the Wetland restricts the distribution of the wastewater, particularly where the media is relatively impermeable. Surface channelling is apparent emanating from the individual inlet pipes out across the surface of the Wetland rather than spreading widthwise to optimise percolation efficiency.

In recognising that the earlier Wetland inlets encouraged the ponding and channelling of wastewater on the bed surface the more recent inlets comprise of an angled down-pipe into a coarse gravel inlet zone ostensibly to encourage the wastewater to penetrate directly into the lower depths of the bed and optimise subsurface flow characteristics. The approach appears to improve wastewater penetration into the beds. This is possibly a result of anaerobic conditions within the depth of the bed being less prone to bacterial slime development which occurs on the aerobic surface layers, and possibly that the inlet pipe by coarse gravel increases the surface area open for infiltration, whilst discharging direct to a sand surface creates a limitation to percolation.

Total subsurface flow by introducing the wastewater to the bottom of the bed is not feasible where there is an inherent resistance to percolation from the Wetland media. Sandy media has limited permeability potential in relation to the hydraulic load imposed upon the immediate area around the inlet downpipes. Consequently, the wastewater seeks its path of least resistance, that being to flood the coarse gravel layer to break onto the bed surface around the inlet down pipe as if the downpipe was not present.

#### 7.5.7 Management Recommendations

- 1) Provide inlet distribution across the whole width of the Wetland rather than at isolated, ie 3, individual points, to enhance infiltration potential and to minimise localised ponding. This can be achieved by increasing the number of inlet pipes, providing a perforated pipe across the inlet zone, providing a distribution pipe with a number of adjustable T-pieces rather than individual inlet pipes, and/or providing a coarse gravel zone across the whole inlet area into which the wastewater is discharged and which will inherently enable the wastewater to distribute through the whole inlet zone and subsequently into the base media.
- 2) Wetlands need not be > 500 mm deep, the greater depth to which the reed root system will actively penetrate, to economise on construction cost and to reduce short-circuiting through the base layer where the root system does not hinder percolation.
- 3) Monitor outflow stand-pipe outlet settings of each Wetland on a daily (weekly as appropriate) basis, and adjust accordingly to ensure wastewater does not excessively flood the influent zones. As the beds are composed of river sand with limited hydraulic permeability potential over the lengths of the Wetlands as established, it is recommended that the outlet weir height be maintained at the mid-height point in beds with low inflow and as required at even lower levels in beds with an outflow.

- 4) Allow primary beds to fill on a bimonthly basis prior to dropping outlet weir position back to the lower operational level to assist in the redistribution of solids matter accumulating within the bed, and particularly from the inlet zone, and to introduce aeration to the lower bed levels.
- 5) Maintain Wetland inlet and outlet zones clear of excessive grass and weed encroachment.
- 6) Flush inlet distribution pipelines regularly ie at least weekly, to remove accumulated solids blocking the surface of the inlet zones.
- 7) Monitor inflow distribution across the bed width to ensure that the inlet pipe system is appropriately levelled and that a nominally even flow is provided across the whole bed inlet zone.
- 8) Clear gravel and associated vegetation from around the influent pipe distribution nozzles and allow wastewater to flow freely onto the inlet zone.
- 9) Clear inlet zone of excessive surface solids and surface slimes accumulation during drainage exercises.

## 8 DISCUSSION OF SOUTH AFRICAN EXPERIENCES

Within the discussion of the individual systems consideration has been given to the reasons for limitations in the treatment performance, whether subsurface flow (horizontal and vertical), and surface flow configurations. A fundamental finding is that the hydraulic control of the system is essential to the effective operation of the system as a wastewater treatment technology. Low permeability of the bed media tends to encourage surface flow rather than filtration through the bed for systems internationally designed for subsurface flow, and similarly, surface flow systems demonstrate significant short-circuiting. These factors minimise available residence times and contact opportunity for optimal treatment.

Although success has been achieved on the pilot scale, by mixing bed medias to optimise permeability, difficulties arise with large systems in maintaining adequate heterogeneity in the mixing and difficulties in preventing short-circuiting and preferential channel formation. Blending tends to set a permeability reflecting the content of fine particles and clays, ie. the blending of soil with a permeability of  $10^{-7}$  m/s with a gravel of  $10^{-1}$  m/s in a 1:1 ratio does not create an effective permeability of  $10^{-4}$  m/s. The permeability may remain of the order of  $10^{-6}$  m/s depending on the potential to develop hydraulic channels, and chemical reactions that affect the structural stability of the media. If blending is to be envisaged careful laboratory evaluations should be undertaken initially to prevent the development of problems after a full scale system has been constructed.

Operation in the vertical mode may also encourage channelling. Considering the Mpophomeni experience, it is possible to project that at a flow of 500 m<sup>3</sup>/d a vertical bed of 1.5 m deep 50 m by 50 m would theoretically create a unit hydraulic velocity of 200 mm/d. If this Wetland were to operate in the horizontal flow mode the unit hydraulic velocity would be 6 670 mm/d as the flow has to flow through an area of 75 m<sup>2</sup> in the vertical cross-section. This suggests that, depending upon the vertical cross-section of the Wetland, the horizontal subsurface flow systems require a media which can be an order of magnitude flow more for the same volume of wastewater.

It has also been demonstrated that the flow path of the wastewater is also considered to affect the ability of the Wetland to remove P. Horizontal flow Wetlands have a longer path length than vertical Wetlands and can take advantage of less important mechanisms (eg. plant uptake and solid state diffusion). Since vertical Wetlands have a short path length, the loss of adsorption and precipitation media through dissolution may constitute an important loss of resource. A longer path length implies a larger store of substrates.

At loadings of 100 mm/d with secondary effluent it should be possible to achieve an acceptable permeability and P removal with most available soils and clay/sand mixes for vertical flow systems. Horizontal flow systems will require lower loading rates to achieve the same relative permeation potential due to the increased path length. The design loading of 200 mm/d appears to be optimistically high for clay based systems, but local conditions may allow such, and even higher loadings dependent upon the degree of treatment required and the relative adsorptive capacity of the soil.

The Letlhabile system has demonstrated the potential, and benefits, of Wetland systems to maintain good final effluent quality, despite variable performance of the more conventional secondary wastewater treatment process preceding the Wetland. This is particularly advantageous in accepting that South Africa is prone to interruptions of the electrical supply as a consequence of climatic and local service conditions and that technical back-up for small local sewage works is generally limited to effectively respond to ensure discharges to the receiving water environments are well protected.

It has been practice to burn the plant growth on an annual or biannual basis, ostensibly to encourage regrowth and reduce surface weed growth. However, it is apparent that the plant litter in surface flow systems, and on the surface of systems designed for subsurface flow but experiencing permeability problems, positively contributes to the sediment, nutrient and pathogen removal capacity of the system by acting as a living biological filter. By harvesting down to the bed surface level, treatment potential can be compromised.

The experiences of Bethlehem and the Kruger Park systems has demonstrated that there is a clear opportunity for short-circuiting within a gravel and sand subsurface flow systems when operated in a horizontal configuration. If this flow path dominates the hydraulics of the whole system the subsurface flow essentially reverts to a surface flow and one could save significantly on the construction costs by negating the gravel or sand media and the subsurface drainage network, the primary capital cost items of the subsurface flow system.

The experience of Ladybrand has clearly illustrated the difficulties in optimising vertical flow through a coarse media to optimise retention within the wetland and to minimise short-circuiting. In such cases, a sand media would be preferable for vertical flow systems.

Despite less than optimal flow conditions and limited plant contributions to pollutant removal, the South African systems do demonstrate significant potential for wastewater treatment. Surface flow systems receiving secondary sewage can achieve removals of COD and SS up to 20 g/m<sup>2</sup>/d, NH<sub>3</sub> and NO<sub>3</sub> removal up to 1.5 and 6.0 g/m<sup>2</sup>/d respectively, but limited pathogen removal of 99%, and low phosphate removal. Subsurface flow soil systems are severely limited by permeability, but where flow is maintainable for secondary wastewaters, COD, SS, NO<sub>3</sub> and PO<sub>4</sub> removal can be in excess of 85%, and pathogen removal of 10<sup>5</sup> fold, but NH<sub>3</sub> removal is low, <30%, due to poor oxygen transfer to the rootzone. Subsurface flow gravel beds can achieve high COD removal rates at loadings up to 100 g COD/m<sup>2</sup>/d with settled sewage, acting as anaerobic filters. Secondary units are then required to polish residual organic, nutrients and pathogens.

## 9 GUIDELINES FOR THE IMPLEMENTATION OF CONSTRUCTED WETLANDS

### 9.1 Primary Wastewater Treatment

- For the treatment of primary wastewaters such as septic tank and anaerobic pond effluents, agricultural and industrial wastewaters with an organic character (>500 mg/l COD), it is recommended that a gravel bed SF system be implemented to provide primary organic reduction in conditions that will limit odour generation.

### 9.2 Maximum Loading

- Primarily based upon the detailed investigations of the South African CSIR, loading to the primary bed can be as high as 100 gCOD/m<sup>2</sup>/d and 1 000 l/m<sup>2</sup>/d with an expectation of > 60% reduction in COD and SS. In practice, it is recommended that at least two primary beds each loaded at a maximum of 50 gCOD/m<sup>2</sup>/d be constructed to provide flow and load contingency.

### 9.3 Bed Depth and Media

- To optimise anaerobic processes in the bed depth and allow extended degradation of residual solids and organic whilst minimising odour generation potential and possible toxic effects on the plant community, the primary bed may be 700-1 000 mm deep containing washed gravel of 20-40 mm diameter and void fraction of > 50%.

### 9.4 Inlet Distribution

- Wastewater should as far as possible be introduced across the full bed width. To further optimise and control hydraulic integrity the length : width ratio should be as great as practical site topography and permeability (K<sub>r</sub>) potential of the media, as

determined by D'Arcy's Law, will allow at the given hydraulic loading. A minimum length to width ratio of 1:1 is recommended for washed gravel, and maximum of 3:1. The inlet zone should be of coarse media to accommodate the elevated unit organic and solids loadings and to allow clearance, as and when required.

### 9.5 Terracing

- Where practical a terraced arrangement and/or series of cells will allow greater hydraulic control and assist in minimising short-circuiting potential and optimises redistribution of flow. Open water and baffled areas within the flow path can assist in maintaining hydraulic integrity through the Wetland system.
- An irregular site may be adapted to provide a desired configuration by the incorporation of baffling or meandering channels in both the FWS and SF option.

### 9.6 Parallel Cells

- The provision of parallel discreet Wetland units allows flexibility in operation and the capacity to alternate feeding regimes to encourage simultaneous nitrification-denitrification and overall wastewater treatment potential.

### 9.7 Vertical Flow

- Vertical flow beds should contain graded media to restrict channelling of the wastewater directly to the underdrain. A surface layer of coarse river sand overlying pea gravel is recommended above the drainage layer. The drainage layer should be arranged to collect the underflow from across the full bed area rather than localised areas.
- Integrated vertical flow units, at  $> \pm 200 \text{ t/m}^2/\text{d}$ , should be provided with parallel cells allowing for alternate feeding and draining regimes, operating single beds on a daily basis, and return after between 3 and 6 days.

### 9.8 Secondary Wastewater Treatment

- Secondary treatment, after a primary SF cell, may be accomplished with either a FWS Marsh, a Pond, a shallow, (250-400 mm), gravel SF, or a Biological Trickling Filter to optimise nitrification potential. The selection being depended upon treatment priorities, site location and relative economics of SF media as compared to FWS, open pond or Biological Filtration.



### 9.9 Secondary Organic Loading

- Secondary FWS and SF Wetland units can be loaded at 15-30 gCOD/m<sup>2</sup>/d or 100-200 t/m<sup>2</sup>/d with an expectation of a further 60% reduction in COD and SS load and > 30-50% reduction in ammonia. A recommended design loading would be 15 gCOD/m<sup>2</sup>/d.

For nitrification-denitrification in a shallow SF or FWS system a loading of 2-5 g NH<sub>3</sub>-N/m<sup>2</sup> may also be applied with the recommendation being to design for a lower loading, ie 2g NH<sub>3</sub>-N/m<sup>2</sup>/d.

A biofilter loaded at 5m<sup>3</sup>/m<sup>2</sup>/d top surface area should achieve comparable nitrification but would have limited overall NO<sub>3</sub>-N removal if identification is required, a Biofilter may be followed by subsequent polishing through an FWS or SF Wetland.

### 9.10 Tertiary Wastewater Treatment

- Where a pond or shallow SF unit is utilised the resultant effluent may require final polishing. A FWS Wetland of macrophytes or grass, or a low rate or recirculating sand filter loaded at 100-200 t/m<sup>2</sup>/d should suffice.
- For PO<sub>4</sub>-P and pathogen removal it is preferable to provide a suitable iron rich media, either as a soil or a soil-sand-gravel mix for which hydraulic permeability can be maintained either by the selection of permeable media mix, the provision of terracing or intermittent loading to draw the water through the media matrix. Coarse waste ash or equivalent may be utilised but leaching of salts and dissolution of fines inhibiting hydraulic integrity must be accounted for.
- Wetland systems are able to remove 10<sup>3</sup>-10<sup>5</sup> pathogens/100 ml, at HRT's >7 days, but they are not expected to produce pathogen free discharges. This is due to the limited hydraulic time within the Wetland system, and the additional contribution from animal and birds frequenting the Wetland.  
If General Standard final effluent quality is required some form of disinfection should be provided.

### 9.11 Hydraulic Control

- Hydraulic integrity is the over-riding factor in ensuring optimal treatment performance. Outlet collection and transfer facilities between Wetland cells should allow for collection across the width of the bed and not encourage preferential flow to a single point.
- Hydraulic and Organic Loading rates indicated above should be used only as a guide and tailored to specific treatment objectives and individual site conditions.

- Recirculation of effluent between cells, the provision of aeration cascades, or more sophisticated aeration and recirculation facilities can improve overall treatment performance by providing additional hydraulic control and better distribution of the contaminant loads throughout the cells.
- Intermittently loading the cells enhances overall treatment efficiency, particularly nitrification and total nitrogen removal.
- For the maintenance and control of water level within the cells, the level of water draw-off should be flexible and adjustable.

The basic requirements for effluent control are:

- a) When the system receives maximum flow, water mounding should not result in surface flow in the upstream section of the bed.
  - b) When the system receives low flow, the outlet level should be controlled to maintain adequate water depth throughout the bed to prevent drying out of the plant root systems, particularly in highly permeable gravel horizontal subsurface flow systems.
  - c) The depths of root contact in water should be as uniform as possible.
- Only where native ground conditions may make seepage excessive or threaten groundwater contamination is it necessary to seal the Wetland bed with a clay or synthetic liner.

## 9.12 Plants

- Local Wetland plant species, preferably *Frogmouths* should be used for the primary SF and FWS cells, although *Typha* and *Schoenoplectus* are acceptable, with dense grass such as blue, bermuda or kikuyu grass in shallow, (<100 mm) FWS/Meadow units.
- Planting density should be as numerous as economically viable to provide in relation to creating as rapid establishment of good plant cover as possible. Planting may be carried out with nursery cultivated seedlings or clumps of shoots obtained from a local natural or Constructed Wetland. Plant spacing should be  $\pm 9/m^2$  in small beds but may be reduced to  $\pm 3/m^2$ , or even  $1/m^2$  in large Wetlands as an economy measure.
- In most cases harvesting of the vegetation is not required, but may be undertaken to encourage more complete cover of the bed surface and to discourage preferential channel formation. Where excess plant material is accumulating the bed may be burned annually without detrimentally affecting system integrity.

### 9.13 System Monitoring

- In order to ensure that the Wetlands are developing and subsequently operating efficiently it is advisable that regular inspections and water quality sampling an analysis be performed, and flow/water level monitoring included in the management of the systems. Monitoring of the system and plant development and basic health on a regular basis would also permit control measures to be taken timeously in the event of flow/water level and water stress problems or aphid infestations occurring.

## 10 CHALLENGES/FUTURE RESEARCH OPPORTUNITIES

**Table 23. Challenges for Future Development of Constructed Wetlands for Wastewater Treatment and Pollution Control (adapted from Haberl 1994)**

Application	Some Challenges/Research Opportunities
Treatment of Primary Settled and Secondary Treated Sewage	Provision of complete integrated Wetland systems, including nutrient removal, for all community sizes.
Tertiary Effluent Polishing	Long-term maintenance of functionality particularly in regard to phosphorus and nitrogen removal, and pathogen destruction
Domestic Water Treatment	Development of Constructed Wetland potential for providing clean drinking water in degraded catchments
Environmental Enhancement	Establishment of appropriate species diversity for integrated Wetland systems.
Urban/Rural Run-off Management	Identification of appropriate sites and strategies for Constructed Wetland systems and associated, design, operation and maintenance requests.
Toxicant Management	Development of understanding and modelling of the processes by which metals and organic can be immobilised and/or transformed
Land-fill and Mining Leachate Treatment	Development of understanding and modelling of the processes by which metals and organic can be immobilised and/or transformed
Industrial Effluents	Development of understanding and modelling of the processes by which metals and organic can be immobilised and/or transformed
Sludge Management	Long-term disposal of residues which may contain substantial levels of heavy metals and toxic material
Biomass Production	Identification and development of uses and viable markets for Wetland products
Groundwater Recharge	Development of understanding of the potential of Wetlands as Groundwater Recharge systems.
Pretreatment and Storage of Water for Reuse Schemes	Assess levels of treatment appropriate to different reuse options and local economics

**APPENDICES**

## A WASTEWATER POLLUTANT REMOVAL MECHANISMS

### A.1 Treatment Performance of International Constructed Wetland Systems

Table A1 illustrates the analysis of the performance of FWS systems for the removal of TSS, BOD<sub>5</sub>, TP, TN and Faecal coliforms (Kadlec 1994).

**Table A1. Regression Analysis of FWS Constructed Wetland Systems Performance (Kadlec 1994)**

Constituent	Regression	Limitations	Unit
TSS	$C_0 = 5,1 + 0,16 C_1$ $R^2 = 0,23, N = 1\ 582$ S.E in $C_0 = 13,6$	$0,002 < q < 28,6$ $0,1 < C_1 < 807$ $0,0 < C_0 < 290$	cm/d mg/l mg/l
BOD <sub>5</sub>	$C_0 = 4,7 + 0,17 C_1$ $R^2 = 0,62, N = 440$ S.E in $C_0 = 13,6$	$0,27 < q < 25,4$ $10 < C_1 < 680$ $0,5 < C_0 < 227$	cm/d mg/l mg/l
TP	$C_0 = 0,34 C_{0,96}$ $R^2 = 0,73, N = 369$ S.E in $\ln C_0 = 1,09$	$0,11 < q < 33,3$ $0,02 < C_1 < 20$ $0,009 < C_0 < 20$	cm/d mg/l mg/l
TN	$C_0 = 0,75 C_{0,77-0,09}$ $R^2 = 0,36, N = 353$ S.E in $\ln C_0 = 0,60$	$0,02 < q < 28,6$ $0,25 < C_1 < 40$ $0,01 < C_0 < 29$	cm/d mg/l mg/l
FC	$C_0 = 6,66 C_{0,34-0,51}$ $R^2 = 0,36, N = 107$ S.E in $\log C_0 = 2,16$	$0,02 < q < 28,6$ $0,25 < C_1 < 40$ $0,01 < C_0 < 29$	cm/d mg/l mg/l

$C_0$  = outlet concentration mg/l,  $q$  = hydraulic loading rate cm/d,  $C_1$  = inlet concentration mg/l

Table A2 (from Knight 1992) illustrates the performance data for 69 FWS and 15 SF or Hybrid Wetland systems in the USA, predominantly receiving secondary wastewaters and ranging in size from 40 m<sup>2</sup> to 1 093 hectares. Tables A3, 4 and 5 for European systems predominantly receiving primary wastewaters from Brix (1993), and Table A6 performance of the Egyptian GBH system from Loveridge (1993).

**Table A2. Treatment Performance of USA Constructed Wetland Systems (From Knight, 1992 Area use variable)**

Constituent mg/l	Influent	Effluent	% Removal
BOD <sub>5</sub>	38,3	10,5	73
Suspended Solids	49,4	15,3	69
NH <sub>4</sub> -N	7,5	4,2	44
Total Nitrogen	13,9	5,0	64
Total Phosphorus	4,2	1,9	55

**Table A3. Treatment Performance of Dutch Surface Flow Constructed Wetland System (Area use >20 m<sup>2</sup>/p.e from Brix 1993)**

Constituent mg/l	Influent	Effluent	% Removal
BOD <sub>5</sub>	257	11	96
COD	530	70	87
Kjeldahl-N	55	22	40
Total-P	14	4.2	30
Suspended Solids	260	10	96

**Table A4. Treatment Performance of European Subsurface Flow Constructed Wetland Systems (Area use ± 10 m<sup>2</sup>/p.e from Brix 1993)**

Constituent mg/l	Influent	Effluent	% Removal
BOD <sub>5</sub>	97	13.1	86.5
Total-N	28.5	18.0	36.8
Total-P	8.6	6.3	26.7
Suspended Solids	98.6	13.6	86.2

**Table A5. Treatment Performance of Vertical Flow Constructed Wetland Systems (Area use ± 5 m<sup>2</sup>/p.e from Brix 1993)**

Constituent mg/l	Influent	Effluent	Removal %
BOD <sub>5</sub>	200	<10	>95
COD	300	<10	>95
Total-N	40	30	25
NH <sub>4</sub> -N	35	<1	>97
PO <sub>4</sub> -P	8.2	0.2	98
Suspended Solids	200	<10	>95
Total Coliform/100ml	29 990	0	>99.99

**Table A6. Treatment Performance of Gravel Bed Hydroponic (GBH) Horizontal Flow Constructed Wetland (Area use < 5 m<sup>2</sup>/p.e from Loweridge 1993)**

Constituent mg/l	Influent	Primary Bed Effluent	Secondary Bed Effluent	Removal %
BOD <sub>5</sub>	92	19	10	>90
Suspended solids	77	15	8	90
NH <sub>4</sub> -N	20	4	1	95
T.Coliforms/100ml	440 000	20 000	4 000	99
F. Coliforms/100ml	210 000	9 000	2 000	99

## A.2 Organic Load Removal (COD/BOD)

Constructed Wetlands generally function as low rate attached growth biofilters for the degradation of organic wastewater pollutants. The plant material, sediments and bed media provides the support and attachment surface for microorganisms able to anaerobically, anoxically and aerobically, (dependent upon oxygen source available) reduce the organic pollutants to CO<sub>2</sub>, CH<sub>4</sub>, H<sub>2</sub>S etc and produce new microbial cells and inert residual solids.

The slow decomposition of plant matter accumulating on the bed surface also provides a matrix of low bulk density, high water holding and cation exchange capacity and thereby a high potential to biologically transform organic material and nutrients.

A detailed assessment of Constructed Wetland systems in the USA (Knight 1992) indicates that BOD removal rates tend to be consistent over time and does not appreciably diminish at the higher loading rates of over 300 kg/ha/d, remaining at between 70 - 90%. Treatment efficiency appears to reduce at low loading rates or inlet concentrations (5 - 10 mg BOD/l) believed to be as a result of internal BOD generation and possibly insufficient media for microbes at such low concentrations, although Green (1994) reports some UK gravel and sand bed systems receiving high quality secondary effluents consistently produced effluents with BOD of 1 mg/l or less.

Removal rate appears to reduce at HRT below to 5 days, with an optimum at ± 7 days. Reed (1988) has suggested a reaction rate equivalent to:

$$K_{20} = K_0 (37,31 \eta^{4,172})$$

in which K<sub>0</sub> = 1,839 for typical wastewaters and 0,198 for industrial wastewaters with high COD. η = porosity.

Overloading of organic materials may result in clogging, decreased treatment efficiency, and odour emissions (Reed 1988). In circumstance where there is a large oxygen demand upon the roots, the root itself will be starved of oxygen and die (Armstrong 1990).

## A.3 Suspended Solids Removal

Constructed Wetlands generally have long hydraulic residence times allowing particulate solids to settle within the Wetland. Additional removal mechanisms are provided by bacterial growth or adsorption to other solids (plants, pond bottom and suspended solids). The outflow suspended solids levels are generally minimal.

Build-up of detrital solids within the system is generally considered low as a result of long retention times allowing mineralization mechanisms. Mitsch (1993) reports an annual sediment accumulation from 6 to 20 mm/y, with high inflow Wetlands having higher sediment accumulation rates than low flow inflow Wetlands. The inlet areas may require

additional attention where high loadings per unit area are evident. Kadlec (1993), found solids removal to occur predominantly in the initial 20 - 40% of the Constructed Wetland.

Since the removal of suspended solids is primarily as a result of sedimentation and attachment mechanisms the removal efficiency is generally very high in Wetland systems up to loading rates greater than 150 kg/ha/d, with an optimal HRT of  $\pm 5$  days. As with organic removal, SS removal efficiency decreases at low input concentrations (Knight 1994).

#### A.4 Phosphate Removal

Removal of phosphate through a Constructed Wetland is primarily by:

- Absorption to inorganic fractions within the media, particularly Fe, Al, Si and Ca compounds;
- Adsorption and absorption to organic and inorganic fractions within the Wetland matrix;
- Plant, algal and microbial uptake.

Since phosphate removal is predominantly determined by physico-chemical immobilisation with media and sediment components the ability to contact the wastewater with the media, and the chemical composition of the media and sediments determines the effectiveness with which phosphate can be removed. Adsorption alone cannot account for all the phosphate removal over a long period of time. According to the Freundlich or Langmuir equations, the adsorption equilibrium is reached in a few hours. Subsequent mechanisms of slow mineralisation and insolubilisation that involves chemical precipitation, biological activities or both, are not well known (Aulenbach 1988). It has been observed that soils have the capacity to regain, and in some cases enhance, their adsorptive capacities after apparently having reached saturation and subsequently been allowed to rest. The phenomenon is explained by the slow dissolution of aluminium and iron compounds creating new sites for adsorption of phosphate with time (Ellis 1967). Alternate drying and wetting restore the adsorption capacity of soils (Ryden 1980), and precipitation and transformation process in soils also contribute (Craft 1993).

Typical maximum Total phosphate removal for unharvested natural Wetlands is given by Knight (1992) as 0,3-0,4 kg/ha/d, although plant uptake is obviously species and condition related and can account for between 0,05 - 1,1 kg/ha/d. Due to natural senescence conditions, much of assimilated material can be re-released with long-term plant phosphate removal being as low 0,002 - 0,05 kg/ha/d. Newman (1993) found an average retention of 1,46 kg/ha/d as a result of plant uptake and other immobilisation mechanisms, whilst Mitsch (1993) found low flow (14 - 20 mm/d) Wetlands retain 1.14 - 1.57 kg/ha/d while high flow (48-54 mm/d) Wetlands retain 3.70 - 7.83 kg/ha/d.

In attempting to quantify the physico-chemical phosphate removal potential of Constructed Wetlands Mann (1990), determined maximum phosphate sorption capacity of 26 and



48 mg/kg for two gravel types used for subsurface flow beds, and Jenssen (1992) 4 Kg/m<sup>3</sup> for light expanded clay aggregate (LECA). Gale (1994) determined phosphate sorption capacities of 196 and 281 mg/kg for sandy soil used in surface flow

**Constructed Wetlands.** Subsurface flow systems tend to encourage chemical precipitation of phosphate, at least in the short-term, with removal rates as high as 15 kg/ha/d, and effluent concentrations below 0,5 mg/l where the media is of an iron or aluminium rich character, and hydraulic permeability is maintained.

## A.5 Nitrogen Removal

Ammonia can be removed during passage through a Constructed Wetland by several processes:

- Biological oxidation to nitrate through nitrification;
- Volatilisation as nitrogenous gases to the atmosphere at elevated pH;
- Absorption to organic and inorganic fractions within the soil/plant microbial matrix;
- Plant, algal and microbial uptake.

Nitrite is usually found as a transition form in very limited concentrations tending to be rapidly converted through to nitrate as the primary oxidised form of nitrogen.

Nitrate is removed by:

- Biological reduction to nitrous oxides and nitrogen gas through denitrification;
- Absorption to organic and inorganic fractions within the soil/plant microbial matrix.

Where low organic and hydraulic loads are applied to the Wetland, the SF and FWS systems can then become essentially a low rate nitrification biofilter whereby nitrifying bacteria are able to compete for sites on the media, sediments and the plant litter matrix with the aerobic heterotrophs. Adequate oxygen to support a degree of nitrification can then be supplied via direct diffusion from the atmosphere as well as that produced by the plants themselves (Williams 1992; Loveridge 1993).

Nitrification is limited by the availability of oxygen to the microorganisms and competition from alternative demands on the oxygen, consequently ammonia removal rates in conventional FWS Wetlands appears to be of the order of 10 kg/ha/d where 70 - 90% removal may be expected (Knight 1992). Nitrogen removal rates in SF Wetlands tends to be low due to the limitations of oxygen transfer except where aeration is enhanced by design or operation, where ammonia removal can exceed 50 kg/ha/d. Hammer (1994) cites conservative loading for Total Nitrogen at less than 3 to 5 kgTN/ha/d and hydraulic loading rates about 20 to 30 mm/d to achieve outflow concentrations of less than 5 mg/l.

Total nitrogen removal, requiring nitrate removal can be related to the availability of organic carbon with rates of up to 100 kg/ha/d potentially available where nitrate rich

waters are combined with correspondingly organic rich wastes. Where the available organic carbon has already been removed, nitrate removal can be related to the availability of carbon from the resident plant and biomass communities and capacity of endogenous denitrification which limits TN removal to  $\pm 10$  kg/ha/d for FWS Wetlands where aerobic surface waters predominate.

Removal efficiency is reportedly variable with loadings between 10 - 80 kg/ha/d believed to be a response to the availability of carbon under anoxic conditions. Rogers (1990) found high nitrogen removal possible with vertical flow Constructed Wetlands, 91% TN removal at a loading of 10 mg/m<sup>2</sup>/d and 5 cm/d, of which > 90% was attributed to plant uptake. Van Oostrom (1994) also found nitrogen removal rates as high as 9,5 g/m<sup>2</sup>/d, and an average of 5,2 to 5,5 gN/m<sup>2</sup>/d for Wetlands treated abattoir effluent with 50% recycle over a planted matrix. The plants (including plant litter) were considered to be responsible for about 50% of nitrogen removal, and developing anaerobic conditions responsible for denitrification.

SF Wetlands generally show good nitrate removal because of the greater capacity to create anoxic conditions and opportunities for immobilisation of high populations of facultative bacteria within the media ecosystem. TN removal in FWS Wetlands tends to decrease at design HRT's of below 5 days (Knight 1992).

#### A.6 Pathogen Removal

Pathogenic bacteria and viruses are removed by such mechanism as:

- Die-off from exposure to unfavourable conditions, including UV in sunlight, and temperatures unfavourable for cell reproduction;
- Predation by other microorganisms resident within the Wetland system;
- Absorption to organic and inorganic fractions within the soil/plant microbial matrix;
- Inactivation by inhibitors produced by plants and microbes within the Wetland system.

Pathogen removal is primarily related to the exposure of the wastewater to UV sunlight irradiation and adsorption to plant, microbial and media materials. Subsurface flow systems, particularly soil media, can achieve removals of 4 - 5 orders due to an enhanced ability to immobilise the pathogens within the soil bed. (Bavor 1994, Williams 1994). Bavor (1992) reports reductions of 3 to 5 orders of magnitude demonstrated for faecal coliform populations and a range of other indicator bacteria and viruses, demonstrating a capability to reach recreational standard water quality (20 faecal coliforms/100 ml). Rivera (1994) only reports removal of 13,6 to 68% for faecal coliforms from SF gravel Wetland units in Mexico, and 4,9% to 99,9% for systems in the UK. Although the presence of plants appears to improve the removal efficiency the difference of < 10% is insignificant compared to the several orders of magnitude of bacteria present in wastewater.

Parasite removal of up to 100% was recorded in planted gravel beds, although present in soil based systems effluent. Williams (1994) found four gravel beds operating at a retention time of about 6 hours, 2 to 3 log reduction in indicator bacteria, and viruses are typical, suggesting adsorption is an important pathogen removal process. Netter (1994) reporting of a septic tank effluent treatment soil based SF Wetland which has operated for 10 years found microbial removal at  $10^3$  to  $10^4$ . However, the mean hydraulic retention time was 25 to 40 days.

## **B THE ROLE OF THE PLANTS AND BED MEDIA IN WASTEWATER TREATMENT**

### **B.1 Contribution of the Wetland Plants To Wastewater Treatment**

Although the plants are the most obvious components of the Wetland ecosystem, wastewater treatment is accomplished through an integrated combination of biological, physical and chemical interactions between the plants, the media and the inherent microbial community.

The plants were previously, and are still often, claimed to provide adequate oxygen via its rootzone to encourage oxidative degradation of the wastewater organic and nitrogen compounds passing through the system. In practice, the amount of oxygen that can be released by the plants is now appreciated to be nominal in most SF systems, and limited to the immediate environment around the roots (Armstrong 1990; Brix 1992).

The limited aeration around the roots effectively prohibits the wastewater from attaining oxidative conditions, and ensures that anaerobic conditions will predominate unless the organic load to the Wetland is itself low, and/or that the Wetland is shallow enough to ensure that the majority of the bed volume will eventually become occupied by an effective macrophyte root system able to 'leak' a reasonable amount of oxygen into the bed, or aeration devices are incorporated into the Wetland design (Burka 1990; Davies 1992; Batchelor 1994).

The benefits of the plants in wastewater treatment Wetlands can then be summarised as:

- i) **Aesthetics.** The primary benefit of a vegetated Wetland as compared to a simple soil or gravel filter for organic and suspended solids reduction is that it adds an aesthetic and ecological appeal to the wastewater treatment unit.
- ii) **Odour Control.** A secondary benefit is that the plant and associated litter layer provides a natural odour biofilter, which assists in limiting odours from the system, such that it can be safely positioned relatively close to the community for which it is to serve.
- iii) **Wastewater Treatment.** A third benefit of the plants and surface litter biofilter is that the wastewater is subjected to aerobic and anaerobic treatment as it passes

through the plant mass, filtering out suspended solids and rendering it fitter to infiltrate back into the media where this is required. This applies both to overloading of the subsurface flow systems creating surface flow conditions, as well as the deliberately designed surface flow systems. The plants themselves generally have a limited nutrient assimilation capacity as illustrated in Table B1 from Rogers (1985), and during senescence significant amounts of assimilated nutrients can be released back into the water body and sediments (Richardson 1985).

**Table B1. Uptake of N and P by Three Common Wetland Species (kg/ha.a)  
(From Rogers 1995)**

Species	N Uptake Capacity	P Uptake Capacity
<i>Cyperus papyrus</i>	1 220	80
<i>Frogmouths communis</i>	2 313	162
<i>Typha latifolia</i>	1 164	179

- iv) **Insect Control.** The surface plant/litter mass also limits the development of nuisance insects, such as mosquito's and gnats in any water that has ponded on the surface by adsorbing the wastewater into the litter mass and over shading any open water.

## B.2 Contribution of the Bed Media to Wastewater Treatment

The media in which the plants are established provides a stable surface area for microbial attachment, a solid media for plant growth, and functions directly in the purification of the wastewater by way of physical and chemical processes.

In FWS Wetlands the media has little effect other than as a support medium for the plants since water only contacts with the top few cm. In SF Wetlands the media practically determines the treatment efficiency of the system by affecting retention time, contact opportunities for organisms with the wastewater and the availability of oxygen, all of which relate directly to treatment capabilities. Selection of the media (soil, sand, gravel, ash or mixtures) has a significant impact upon the design basis for SF systems.

## B.3 Stability of Constructed Wetland System in Wastewater Treatment

The water depth in FWS systems is generally shallow, < 300 mm, to encourage plant growth in the free water interface, consequently FWS systems tend to require larger surface areas than the equivalent SF system, and require system design to ensure the wastewater optimally flows through, and utilises the open water areas.

As FWS systems rely on the matrix of plant biomass for microbial attachment, consideration needs to be given to the fate of the plant biomass during periods of senescence where the available support material decreases and variable die-back of plant stands can significantly affect flow paths and hydraulic detention times. This is particularly

important in FWS systems as plant senescence also coincides with reduced temperatures and associated biological reaction kinetics.

Attachment sites in a SF system will tend to be more stable than in a FWS system, microbial concentrations will be expected to be greater, and temperature fluctuations less significant. These factors should result in a more balanced organic degradation performance, particularly under winter conditions. Whereas nutrients assimilated in the plant biomass of FWS systems is potentially released directly into the surface water, winter senescence nutrients are more likely to remain immobilised in the media matrix of SF systems.

FWS Wetlands do permit algae and floating macrophyte communities to develop in the free water interface which tend to be significantly more photosynthetically active than macrophytes in generating O<sub>2</sub>, and indirectly in removing CO<sub>2</sub> from the water causing an increase in water pH towards the alkaline which can assist phosphate precipitation and ammonia volatilisation.

Sediments and plant litter forming on the soil surface of FWS Wetlands also provides a supplemental carbon source for denitrification such that nitrogen removal can readily occur simultaneously, whereas nitrogen removal in SF systems is severely limited by the ability of oxygen to get to the subsurface water flow and nitrification occurs where organic demand is removed.

A further aspect to the FWS's is the general need to provide some form of nuisance insect control, particularly mosquitos, which readily proliferate in shallow wastewaters. Although natural Wetlands tend to have developed natural biological balances, FWS's require the provision of fish, usually *Gambusia* species, which will harvest the nuisance insects and maintain an acceptable insect population level. As systems develop there will usually be a natural immigration of other predator species, particularly frogs, and other amphibians which will further contribute to insect control.

### C. CONSTRUCTED WETLAND DESIGN MODELS

Although Constructed Wetland systems have been implemented internationally for over 20 years, there are still disparities in design philosophy and practical performance reliability of operating systems. It is also apparent that design models which are based upon identifying a large number of limiting factors and reaction kinetics is not always practical, particularly where the primary consideration is for a relatively simple design basis for a low maintenance technology.

Early Constructed Wetlands specifically designed for wastewater treatment tended to adopt the SF approach where the wastewater was encouraged to flow through the media in which the plants were established rather than over the surface. The design basis reported in the literature for this approach tended to assume a simple relationship between biological degradation of BOD and hydraulic detention time proximating to first-order plug flow kinetics (Boon 1985);

$$C_e = C_i \exp (-K.t)$$

where  $C_i$  and  $C_e$  = influent and effluent BOD<sub>5</sub> mg/l,  $K$  = temperature dependent rate constant,  $d^{-1}$ ,  $t$  = hydraulic detention time,  $d$ .

A generalised rate constant ( $K$ ) of 5,2 is reported to describe the removal of BOD from sewage in a bed which is to be 600 mm deep operated at a minimum temperature of 8°C, approximating to 2,2 m<sup>2</sup>/p.e for domestic sewage BOD and suspended solids removal. However, except in low-risk situations where the effluent quality is not critical this seems to be optimistic (Tannersdorf 1986; Cooper 1988) and the European Guidelines (WRC 1990) recommend a  $K_{BOD}$  rate constant, of 0.1 for design purposes, or a Wetland surface area of 5 m<sup>2</sup>/ person served by the system for settled domestic sewage or septic tank effluent. This largely ignores the specifics of hydraulic and reaction kinetic factors, nutrient and pathogen removal requirements.

The Water Pollution Control Federation, Manual of Practice, (WPCF 1990), indicate the temperature coefficient be based upon a modified van't Hoff-Arrhenius equation, where:

$$K_T = K_{20} (1,06)^{T-20}$$

$K_T$  = rate constant at temp  $T$ ,  $d^{-1}$ ;  $K_{20}$  = rate at 20°C,  $d^{-1}$ ; and  $T$  = operating temp °C.

This description of biological degradation rate constants is supported by several authors (Tchobanoglous 1980; EPA 1988; Conley 1991; Crites 1992) although Conley (1991) suggests 0,7  $d^{-1}$  for preliminary design, noting that coefficient impacts upon bed volume not always represented in designs based upon surface area and a shallow bed depth.

In the SF concept, to ensure predominantly subsurface flow is maintained, the European Guidelines (Cooper 1990) recommend hydraulic slope be provided according to D'Arcy's Law as:

$$(dh/ds) = Q_s / (Ac.K_f)$$

$dh/ds$  = bed slope inlet to outlet, m/m;  $Q_s$  = average flow, m<sup>3</sup>/s;  $K_f$  = hydraulic conductivity of full developed bed, m/s;  $Ac$  = cross-sectional area of bed, m<sup>2</sup>.

Although it has been suggested that conductivity of a soil based Wetland would stabilise to  $\pm 3 \times 10^{-3}$  m/s as the root structures develop flow channels (Boon 1986), this has not been found to occur in practice and the European Guide (Cooper, 1990) further recommends that a design hydraulic conductivity of no greater than the original media be used. It is similarly advised that the length : width ratio of the Wetland should provide wastewater velocities through the media which will not encourage short-circuiting, scouring or erosion. Boon (1986) indicated a maximum velocity of 6.4 m/d for soil bed systems.

Simple Wetland system design models based upon hydraulic detention time calculated as a function of the subsurface bed void volume and flow rate ignores the practicalities of the media not being homogenous in character and the presence of the roots, rhizomes and media debris. The US EPA Guidelines (1988) recognise the hydraulic constraints of soil media and recommend the use of sands or gravelly sands in SF systems. Table C1 illustrates data presented for the reaction kinetics and hydraulic conductivity for sand based

SF systems:

**Table C1. Hydraulic Conductivity and Reaction Rates for Subsurface Flow Media Types (From EPA 1988)**

Media Type	Max 10% Grain Size.mm	Porosity (n)	Hydraulic Conductivity (K <sub>s</sub> ) m <sup>2</sup> /m <sup>2</sup> .d	K <sub>20</sub>
Medium Sand	1	0.42	420	1.84
Coarse Sand	2	0.39	480	1.35
Gravelly Sand	8	0.35	500	0.86

In practise, a large proportion of the wastewater pollutants are entrained within a limited area of the inlet zones or headworks to be degraded over time, and does not become effluent BOD. Reed (1988) proposed that the overall BOD reduction in the Wetland can then be represented as:

$$C_e/C_i = F \cdot \exp(-K \cdot t)$$

where  $F$  is the fraction of BOD which does not settle out in the inlet zone.

Crites (1992) indicated the  $F$  fraction can range from 0.52 for primary or septic tank effluent to 0.75 for pond effluent and 0.8 for secondary or tertiary effluents. The difference in  $F$  fraction largely being considered to be related to the characteristics of the suspended solids, and potential to settle or be filtered through the inlet zone. Primary effluents generally have readily settleable solids, whilst secondary and pond effluents generally have less readily settleable suspended solids, particularly algae and colloidal solids.

The detention time is corrected for the fraction of Wetland volume occupied by plants and litter, using a void ratio typically 0.75 (Reed 1990). Consequently, a Wetland system may be better defined as a number of unit processes, providing a high rate primary zone for up to 75% of the organic load removal and then secondary and possibly tertiary units to degrade the residual pollutants.

Although these assumptions have primarily been related to FWS systems, the basis is applicable to SF systems and consideration needs to be given to the validity of present headworks BOD loss for conditions of significant evapotranspiration or rainfall, and where transient conditions occur, such as those occasioned by pump shut-off or start-ups, rain events, and the diurnal cycle of evapotranspiration (Kadlec 1989).

In his review of Wetland system design Tchobanoglous (1992) presented a model which characterises the fate of pollutants in a one dimensional (horizontal) direction, given by:

$$\frac{dCA}{dt} = \frac{\left( -Vx \frac{dCA}{dt} + Dx \frac{d^2CA}{dx^2} + G \right)}{\alpha(1 + \beta)}$$

$\alpha$  = total porosity,  $m^3/m^3$ ;  $B$  = retardation factor accounting for sorption and phase change  
 $C_{A_s}$  = concentration of compound A,  $g/m^3$ ;  $V_x$  = average fluid velocity in the X-direction,  $m/s$ ;  $D_x$  = effective longitudinal diffusion coefficient,  $m^2/s$ ;  $x$  = distance,  $m$ .  $G$  = lumped parameter used to account for all generation terms,  $g/m^3/s$ .  $G$  accounts for rate expressions for processes including bacterial conversion, gas adsorption/desorption, sedimentation, natural decay, adsorption, volatilisation and chemical reactions.

Rather than the first order, saturation and Monod-type rates commonly used to define the processes occurring in Constructed Wetlands, the materials balance for a contaminant subject only to adsorption is given as:

$$dS/dt \{b/\alpha + dC/dt = -V_x dC/dx$$

$S$  = mass of solute sorbed per unit mass of dry materials (composite function may be required, depending on type of Wetland),  $g/g$ ;  $\{b$  = bulk density of the material comprising the solid surfaces in the Wetland,  $g/m^3$ ;  $\alpha$  = porosity;  $C$  - concentration of contaminant in the liquid phase,  $mg/l$ ;  $V_x$  - average fluid velocity in the X (inlet to outlet) direction,  $m/s$ .

The US EPA (1988) recommend that factors accounting for the coefficients of specific surface area for microbial growth be considered for FWS Wetlands, such as the surface area of vegetative stems and leaves in the water column. For SF Wetlands the specific surface area for microbial growth is considered important but not critical, whilst the media porosity is critical in predicting the required area for a given level of treatment. Media porosity is taken to have a direct relationship with microbial degradation rate constant. Such detailed models, although providing significant insight into the functioning of defined Constructed Wetlands, are difficult to relate to practical conditions, and particularly to large Wetland expanses, where the flow characteristics and retardation factors are not homogenous and therefore not definable in terms of simple plug flow kinetics.

Whether the Wetland is operated in a surface flow mode or subsurface, experience is demonstrating that flow hydraulics are not uniform, which subsequently becomes the primary limiting factor in determining the hydraulic retention within the Wetland and contract opportunities. (Kadlec 1988, Kadlec 1992, Haberl 1992, Netter 1992, Wood 1994). The observations of Kadlec (1992) relative to FWS Wetlands appear equally applicable to the SF regime. The mixing characteristics of wastewater flowing through a Wetland are an intermediate between plug flow and well mixed, where the open void areas are likely to be mixed and dense areas plug flow, even for long narrow Wetlands. It may also therefore be interpreted that as with Kadlec's finding for freewater systems, assuming plug flow conditions in subsurface Wetlands can produce rate constants that are in error by as much as a factor of 4, and the hydraulics possible within the Wetland effectively control the performance of the system rather than the unit degradation rates, temperature constants, settlement and immobilisation within the inlet zone, or rates of oxygenation.



## D DESIGN GUIDELINES

### D.1 Siting

When planning the siting of a Constructed Wetland system for wastewater treatment the following factors have to be considered:

- elevation of land in relation to the town (or wastewater treatment works) i.e. gravity flow versus pumping is to be considered,
- topography (whether steeply sloping or flat) and whether valleys or depressions could be made use of to reduce costs,
- type of soil (rocky, clayey or sandy soil), which influences excavation.
- groundwater pollution potential; i.e the distance from water sources, boreholes and wells.
- prevailing winds. Wetlands should preferably be down wind of the residential area. If correctly loaded and well operated, and keeping mosquito breeding in check, secondary treatment Wetlands need not be further than 300 m away from the nearest habitation, for treating volumes of greater than 250 m<sup>3</sup>/d, and as close as 25 m for individual houses or volumes less than 1 m<sup>3</sup>/d.

### D.2 Layout

Wetlands on flat ground may have any practicable shape. Overflows from Wetland cell to Wetland cell could consist of sufficiently large connecting pipes, overflow weirs, or rip rap arrangements which could function to aerate and further distribute the effluent across the width of the Wetlands when passing from one Wetland to another. On steeper ground, the Wetland would be long and narrow along the contours and special overflows have to be designed.

Sub-dividing the required surface area into individual units allows greater hydraulic control, flexibility in maintenance, and treatment reliability. These may be further arranged to offer parallel or series flow. Compartmentalisation also allows integration of independent Wetland components ie subsurface flow pretreatment, ponded areas and marshes, to optimise treatment and site limitations.

### D.3 Organic Loading

Organic loading should be designed to limit odour and insect problems or hydraulic problems in the inlet zones. The loading may also be determined by the carbon required to enhance nitrogen removal via denitrification where the primary objective of the individual Wetland cell is nutrient removal.

The EPA Design Guidelines (1988) suggests the upper loading of Wetlands is of the order of 110 kg BOD/ha/d which is comparable to the recommended loading rates for Stabilisation Pond systems in South Africa (WISA 1988). This loading seems to have been based upon the assumption that BOD removal is determined by the amount of oxygen that can be supplied by the plants and surface diffusion. This assumption discounts the

significant amount of BOD that is removed anaerobically and anoxically as well as immobilised within the sediments for prolonged degradation. The Tennessee Valley Authority (Gover 1994) recommend a design limit of 0,24 kg/m<sup>2</sup>/d of BOD at a Wetland systems inlet area, which can be increased as high as 0,49 kg/m<sup>2</sup>/d of BOD in large systems, systems on steep slopes, and where reduced inlet width is advantageous (Gover 1994). Such loadings are comparable to loadings recommended for Biofilter systems in South Africa which may be considered to be far better aerated. High influent loadings may therefore tend to allow anaerobic conditions to dominate, with subsequent odour generation to be considered in the location of the site.

#### D.4 Hydraulic Loading

Hydraulic loading is generally determined by the organic or nutrient loading forming the primary design basis. Where the system configuration is for a SF system, the hydraulic loading can be a more significant factor in determining the length to width ratio of horizontal flow systems or the overall surface area of vertical flow systems.

FWS systems generally have hydraulic loading rates less than 200mm/d whilst hybrid systems generally range for 50 to 200mm/d, and Constructed SF Wetlands range from 20 to 30 mm/d. From the review of USA experiences, Knight (1992) recommended HLRs not exceed 25- 50mm/d for FWS and 60-80mm/d for SF Wetlands.

For SF Wetlands it has been suggested (Boon 1986) that superficial velocity be kept under 8,6 m/d to prevent disturbance of the root-rhizone structure and subsequent poor plant growth and to allow sufficient contact time for treatment. This guideline restricts the use of long, narrow beds or beds with steep hydraulic gradients. Although it seems reasonable to restrict the superficial horizontal velocity there does not appear to be a strong theoretical basis for the maximum value published. For gravel bed channels Green (1993) reports an optimal loading to the inlet width to be 0,4 m<sup>3</sup>/m<sup>2</sup> at a bed depth of 0,6 m being 5 m<sup>3</sup>/m<sup>3</sup>.

#### D.5 Detention Time

Treatment performance is related to detention time which the wastewater is retained with the system. This is determined by the void volume in the system and water depth. Estimating the detention time in a Wetland system can be difficult. Flow characteristics can create dead zones as well as preferential flow paths. Similarly, changes in development of the plant cover and surface topography affects both flow paths and void volume over time.

Knight (1992) reports a detention time of 6-7 days as optimal for primary and secondary treatment in FWS Wetlands, whereas longer periods can give rise to stagnant anaerobic conditions, but are required for significant TN and TP removal. SF Wetlands have been found to perform highly efficiently at detention times of < 1 day in terms of BOD and SS removal (Cooper 1990; Green 1994; Combes 1994; Hiley 1994). In several cases efficiently at TN and TP removal where suitable loading conditions and media are provided, particularly where operated in the vertical intermittent flow regime (Williams 1992; 1994; Cooper 1994; Haberl 1994).

## D.6 Evapotranspiration/Infiltration

The water losses due to evaporation and infiltration can affect the feasibility of the various Wetland designs in arid climates, and their performance during peak summer months. Infiltration would be expected to be low in relation to the hydraulic loading rate of most Constructed Wetland systems, but may be of concern if groundwater protection is required or the loading is so low or irregular that for certain periods the Wetland system may enter a negative water balance situation.

Evapotranspiration rates from Wetlands and lake evaporation are roughly equal (Hammer 1992, Martin 1994), although on a short-term basis the vegetative effects can be variable, due to growing season enhancement and off-season mulching effects of litter. Marsh (1994) utilizes an evapotranspiration/evaporation water loss factor of 0,85 x site pan.

Infiltration or seepage rates will be variable dependent upon site factors such as the base soil conditions, degree of compaction upon construction, natural sealing capacity of the wastewater by physico-chemical and biological interactions and slimes development, and the ability of plant roots to penetrate the base and create preferential flow paths.

Knight (1990) reports measured values for Florida cypress domes were from 1.3 to 4 mm/d, 0.0mm for a Michigan fen and 5 mm/d in a converted rice field Wetland in South Carolina.

## D.7 Pretreatment

Some form of pretreatment, at least to the primary level, is typically used for SF Wetland systems. Systems without pretreatment are reported to have frequent clogging at the influent end, excessive surface deposits, and problems with insects and odours (Bucksteeg 1985). Primary treatment using septic or conservancy tanks is suitable for small to moderate sized systems. Several recent Chinese systems treating combined domestic and industrial wastewater incorporate a primary Upflow Anaerobic Sludge Blanket (UASB) reactor, resembling a large upflow septic tank, as pretreatment for gross organic and suspended solids removal prior to FWS and SF Wetlands (Hu 1994). As a low technology approach Anaerobic and Facultative Ponds may be an acceptable form of preliminary treatment but can add large concentrations of algae as evident at the South Africa

Constructed Wetland Systems of Ladybrand and Lethlabile. In these cases a variable level draw-off in the lagoon may help reduce the algal load on the Wetland component.

## D.8 Aspect Ratio

Treatment performance is largely the ability to ensure the full bed area is utilised and that short-circuiting is minimised and contact with the plant roots and stems optimised. This can be achieved by the provision of a high length to width ratio, or adequate inflow distribution and outflow collection, and placement of internal baffles as flow integrators. Knight (1992) found that for FWS Wetlands the removal efficiency for BOD and TN increases and apparently levels off at a length:width ratio greater than about 4:1 to 6:1, although efficient systems have operated at ratios of up to 75:1.

For horizontal flow SF Wetlands the hydraulic permeability of the media tends to set the length:width ratio. The lower the permeability the greater the length such that SF systems tend to mainly be 1:1 or less. Where the media is highly permeable ie coarse gravel, and hydraulic gradient is enhanced by base sloping and outlet level control SF channels of 50:1 can, and are, successfully utilised. In particular the longer channel configuration is believed to enhance the capacity to remove carbon and simultaneously nitrify and denitrify in a single unit by allowing oxygen gradient to be generated along the path length.

#### D.9 Water Depth in Free Water Systems

The water level in systems and the duration of flooding can be important factors in the selection and maintenance of Wetland vegetation. *Typha* grow well in submerged soils and may dominate in standing water of over 150 mm. Frogmouths and other reed species occur along the shorelines of water bodies where the water table is below the surface but will also grow in water depth of deeper than 1 500 mm. Rushes, such as *Scirpus*, can tolerate long periods of submergence and occur at water depths of 75-250 mm, above which they tend to be out competed by *Typha* or *Frogmouths*. Sedges, such as *Cyperus*, generally prefer moist partially submerged soils.

Where alternative Wetland plant species are to be considered for environmental or aesthetic requirements it is necessary to consider the hydrological adaptability of the plant in selecting its position and suitability for the Wetland system.

#### D.10 Subsurface Flow System Bed Depth

SF systems have generally been designed with a bed depth of  $\pm 600$  mm to accommodate the root development of the plants (Cooper 1990). However, plant roots have not always been found to readily penetrate such depths and the bed profile remain primarily root free.

Kadlec (1994) found plant roots not to penetrate further than 100-150 mm in gravel bed systems. Adcock (1994) reports that a clay-based Wetland demonstrated very little penetration of plant roots penetrating the clay, but rather forming a solid mat of root hydroponically in the overlying water layer. Breen (1994) found root densities to be partitioned between the upper and lower layers on a 2:1 split respectively of SF Wetlands nominally at 600 mm depth.

The GBH systems utilise a bed depth of  $\pm 250$  mm (Williams 1992, 1994), and there seems to be little benefit in providing media for depths above 500 mm, except where necessary to provide a hydraulic slope to the base of the bed, whilst the surface remains flat, which may result in the inlet being unacceptably shallower than the outlet.

#### D.11 Media for Subsurface Flow Systems

There are numerous media types and combinations that may be used, dependent on desired treatment effect. These range from the coarse gravel of the Krefeld systems (Seidel 1976), waste power station ash (Wood 1988) to phosphate deficient clayey soils often used in the Root Zone Method (Cooper 1987; Healey 1988). Local media types should be evaluated

in terms of their hydraulic permeability and nutrient (esp. P) adsorption capacities.

For carbonaceous and nitrogenous removal, a coarse sand or gravel is preferable, soils with a high Al or Fe content are required for P removal. The permeability limitations of media, particularly soils, will ultimately be the deciding factor on the hydraulic loading that the subsurface flow Wetland system can accommodate where pollutant adsorption is the desired treatment mechanism. Table D1 illustrates a range of physical characteristics for peat and mineral soils (Faulkner 1994).

**Table D1 Soil Physical Characteristics (From Faulkner 1994)**

Soil Type	Total Porosity (%)	Hydraulic conductivity (m/d)	Bulk Density (g/cm <sup>3</sup> )
<b>Peat</b>			
Fibric	>90	>1,3	<0,09
Hemic	84 - 90	0,01 - 1,3	0,09 - 0,20
Sapric	<84	<0,01	> 0,20
<b>Mineral</b>			
Gravel	20	100 - 1 000	~ 2,1 <sup>g</sup>
Sand	35 - 50	1 -100	1,2 - 1,8
Clay	40 - 60	<0,01	1,0 - 1,6

#### D.12 Inlet Arrangement

Inlet design has been found to have significant effects on the hydraulics and can give poor and uneven hydraulic conditions (Bavor 1994). This applies to both FWS and SF systems where influent is introduced at individual points rather than evenly across the inlet area.

For the horizontal SF systems the feed is introduced across the width of the inlet area. The inlet zone serves to distribute the incoming wastewater into the main media throughout its depth. This is particularly important to reduce short-circuiting and surface flow potential. To improve the distribution an inlet zone filled of 60-100 mm stones 0,5 to 1 m wide can be constructed.

Whilst the practice of burying the inlet pipework in the inlet gabion with riser pipes at about 5 m intervals have been successful, more access to the distribution system is advisable. Riser pipes have been adjusted monthly to remove humus solids or a tanker hose may be connected about twice per year. Also glass fibre reinforced concrete inlet channels with adjustable weir plates at 1 m intervals has found favour with plant operators (Green 1994).

In some systems, a simple pipe with a series of adjustable T-pieces has been used to act as an inflow distributor across the bed width.

For vertical flow systems the influent can be introduced from herring-bone agricultural piping or central channels, spray systems or contoured channels criss-crossing the surface to approximate even distribution to the whole area. An alternative is to create a single inlet zone similar in form to that of the horizontal flow systems and allow a layer of liquor to remain on the surface (50-100 mm). This will form a combination of the horizontal and vertical flow systems, since a proportion of the inlet area will be performing the majority

of the treatment (particularly filtering action) as effluent percolates through the system.

The additional capital and operating cost of providing multiple inlet points should be weighed against the advantages of step feed and the creation of nominally completely mixed Wetland systems as compared to nominally plug flow.

### D.13 Bed Slope

SF systems are designed with the minimum slope needed to allow the water to pass through the bed (calculated from the D'Arcy's Law equation) and to use a level surface to permit complete flooding for weed control. Many cases of surface flow with systems initially designed for subsurface flow are believed to be due to inadequate hydraulic design.

Kadlec (1988) found significant water mounds can develop due to vegetation resistance. Water will mound near the inlet to provide the necessary head to drive water through the vegetation which may cause problems in berm stability and short-circuiting in FWS systems with large length to width ratios.

Butler (1991) reported the GBH gravel channels demonstrate predominantly subsurface flow at a loading of 5 l/min/m bed width. Extra flow capacity can be achieved by increasing the bed depth, provided the depth does not inhibit plant establishment.

### D.14 Outlet Control

The most effective way to provide sufficient hydraulic gradient and control in addition to that provided from D'Arcy's law and base slope, is to locate the effluent manifold at, or below, the level of the bed bottom and connect that to an adjustable outlet pipe or gate. In this manner, the water level in the bed is adjustable and can be better maintained below the media surface for all, or the majority of the bed.

The surface flow, meadow systems may involve simple discharge to a single inlet zone consisting of a coarse material to assist distribution and filtering prior to the mass of the bed system. These will usually have large length to width ratios to capitalise of inlet construction requirements.

### D.15 Plants

It is generally accepted that better wastewater treatment is achieved in vegetated rather than unvegetated beds, and largely interpreted to be a result of an oxygenated rhizosphere, although the amount of oxygen provided to aerobic microorganisms is not well defined.

The more common vegetation species planted in Constructed Wetlands are reeds (*Fragmites Sp.*) bulrush (*Typha Sp.*) and cattail (*Scirpus Sp.*). Other plant species utilised include pickerelweed (*Pontederia Sp.*), dutch potato (*Sagittaria Sp.*), duckweed (*Lemna Sp.*) and miscellaneous sedges, rushes and grasses.

In general, plants that are available locally should be used, this will not only blend in with the environment to a greater degree, but will also be of economic advantage for the initial planting, and subsequent replanting if required.

#### D.16 Planting

Constructed Wetlands have been planted in a number of different ways:

- i) using rhizome sections
- ii) using clumps of reeds
- iii) using seedlings grown in a greenhouse.

Lawson (1988) examined the use of clumps, seedlings, stem cuttings, rhizome sections and direct seeding and favoured using seedlings because they tended to provide more rapid cover. A bed planted with seedlings could be substantially covered after the first growing season having a greater density of shoots and a more uniform cover than a similar bed established from rhizome sections. Lawson (1988) also recommends planting rhizomes in late spring using small rhizome segments with one or two growing shoots planted at a density of at least  $2\text{m}^{-2}$  and at an oblique angle with some portion above the water level.

The water level should be kept as high as possible to suppress weeds, minimise the effects of frosts and prevent droughting, say 5 cm above bed level.

Green (1994) reported good bed reed cover after two seasons when established for nursery cultivated stock other than a downward grading in the height of the reeds towards the outlet. At the present time, there are few organisations selling seedlings but propagation is now well-defined and it should be possible for an intended user to either grow its own supply or provide the information to a local market gardener.

#### D.17 Construction

The hydraulic performance of either type of Wetlands can be significantly influenced by improper construction, and several systems with short circuiting of flow have been built. The FWS system must be carefully graded to ensure uniform flow, but compaction may not be necessary. Only where the resident soil base is unsuitable for direct planting (ie clay which restrict root penetration ability), is it necessary to provide a layer of rooting media.

Where it is necessary to prevent or minimise seepage a sealant of clay (with hydraulic conductivity of less than  $10^{-8}$  m/s), bentonite, synthetic fabric (with a smooth surface and about 1 mm thickness), or asphalt is required. SF beds need careful control during construction due to the traffic involved with placement of the media. In several cases the bed had been carefully graded, and then that surface was seriously disrupted when delivering the media.

Hammer (1994) reports that the incorporation of perpendicular deep water zones in FWS Wetlands can eliminate the need for high length-to-width ratios by redistributing water at several points throughout a Wetland cell to correct for the inevitable short-circuiting that occurs in shallow-flow systems. Deep water zones effectively increase the ratio between

actual and theoretical hydraulic retention times more cost-effectively than constructing long, narrow Wetland cells.

#### **D.18 Operation**

Intermittent flow can assist in overall pollutant removal, particularly with SF systems by allowing the bed to drain and draw in additional oxygen. May (1992) reporting on UK gravel bed channels systems found intermittent flow to allow almost complete BOD and ammonia removal, whilst continuous flow onto the beds discourages nitrification.

The beneficial effects of using recycle flows are given as (i) to reduce the concentration of BOD (ii) to control the transport of contaminants to achieve effective treatment and (iii) to control the production of odour Tchobanoglous (1993). If the concentration of BOD and suspended solids is too great, the oxygen transported to the plant roots may be wasted in treating sludge that accumulates around the roots, as opposed to treating the organic matter in the fluid bulk. Consequently recycle assists in balancing the loading to the inlet area.

In nominally plug flow Wetland systems sludge will first accumulate near to the inflow and progressively extend towards the outlet zone across the Wetland until it begins to affect effluent quality. The need for periodic drying to degrade surface slimes needs consideration at the design stage to allow continued operation of a treatment system whilst part is off-line drying.

Tables D2 and D3 extracted from the E.C. Guidelines (1990) indicate unpredictable and predictable system disturbances and associated management opportunities.



Table D2 Unpredictable System Disturbances for Constructed Wetlands Treating Wastewaters (From E.C. Guidelines 1990)

Disturbance	Systems	Water Inflow	Water Outflow	Water Depth	Dilution	Recirculation	Pretreatment Pond	Chemical Addition	Vegetation Harvest	Replant	Prodator Control
Record storm event	High hydraulic loading rates	x				x	x				
	Decreased storage capacity	x					x				
	Insufficient residence time	x	x	x	x	x	x	x			
	Channelling	x					x				
	High Sediment loads			x			x				
	High chemical loads		x		x	x	x	x			
Change in Chemical constituents and concentrations	High chemical loads	x			x		x	x			
	Increased toxicity (vegetation wildlife)				x				x	x	
	Release of chemicals from Sediments/vegetation		x	x		x				x	
	Change in chemical form			x	x		x				
Vegetation damage	Increased debris, flow hindrance	x		x						x	x
	Elemental release from vegetation		x	x		x				x	x
	Change in conditions for replanting	x		x		x	x		x	x <sup>a</sup>	
Pests mosquitoes,	Complaints from neighbours			x					x		x
	Reduced flow and water level control										
Malfunction/ Construction failures	Reduced flow and water level control	x	x	x	x	x	x	x			
Design flaw	Inability to respond to need for changes in operations										
	Limited treatment capacity										
	Limited lifespan										
<sup>a</sup> New Species. <sup>b</sup> All operation modifications may need to be considered											

Table D3 Predictable System Disturbances for Constructed Wetlands Treating Wastewaters (From E.C. Guidelines 1990)

Disturbance	Features	Symptoms	Operational Modifications
Start up	Vegetation establishment Microbial flora colonization Technical system debugging	Widely fluctuating inflow-outflow chemistries, after taking flow velocity changes into account	Control loading rates, i.e., water flow rate, chemical considerations <ul style="list-style-type: none"> <li>• water inflow rates</li> <li>• freshwater source</li> </ul> Control water depths - critical for vegetation establishment and development of conditions suitable for target microbial populations Dilution/recirculation Chemical additions
Seasonal	Extreme precipitation	High loading rates	Control loading rates, i.e., water flow rates chemical concentrations <ul style="list-style-type: none"> <li>• water inflow rates</li> <li>• dilution</li> <li>• recirculation</li> </ul>
		Decreased storage capacity	Increased storage capacity <ul style="list-style-type: none"> <li>• stormwater diversion</li> <li>• detention pond</li> <li>• increased water depth</li> </ul>
		Insufficient residence time channelling	Control outflow rates Installation of baffles
	Extreme temperatures	Insufficient flow	Freshwater source, recirculation, parallel cells
		Freezing; sheet flow over ice surface	Reticulation, aeration, control water depth Preheated water
	Vegetation growth/decay	Flushing of chemical, nutrients, and microbes from decaying vegetation, sediment	Secondary treatment pond treatment Vegetation harvest or burning Recirculation to increase nutrient retention Drawdown and oxidation
	Population composition changes (microbial, algal)	Gradual change in treatment efficiency	Secondary treatment pond Reticulation

## **D. 19 Management Opportunities (Adapted from Tchobanoglus 1993)**

### **D.19.1 Managements Aspects**

While improved designs for Constructed Wetlands and greater understanding of the processes occurring in them are important, of equal or even greater importance is the long-term operation and maintenance of the Wetland treatment systems once they are constructed. Management techniques must be developed that will allow for operational changes to be made in response to changes in the wastewater characteristics, effluent quality, climatic conditions, and effluent discharge requirements. Depending on the design objectives, the major operational and management issues associated with Constructed Wetlands include:

- Hydraulic controls
- Structural integrity
- Water quality structures
- Water quality requirements
- Vector (pest) control, particularly in FWS Wetlands
- Vegetation control (manipulation)

Where the system is intended to provide sociological benefits, issues to be considered include:

- Wildlife habitat management
- Education
- Recreation

For each of the operational and management issues, a clear set of operating instructions must be developed for each system so that corrective actions can be taken as the need arises. In dealing with each of the issues, it will be important to define (1) the operating goals, (2) the basis for problem identification, (3) the causative factors, (4) the appropriate management strategies, (5) the lead time, and (6) the method(s) that will be used to evaluate the effectiveness of the control. Examples of the type of information that must be developed for vector and vegetation control for Constructed Wetlands are identified in Tables D4 and D5, respectively. Having a set of instructions for the operation of a Constructed Wetland will improve the operation and performance of these systems.

### **D.19.2 Monitoring**

Monitoring issues are related to regulatory requirements, process performance and control, the fate of specific constituents, and the development of a database.

**Table D4 Operational issue - mosquito control (From Tchobanoglus 1993)**

Item	Objective/action
Operating goal	Control of mosquitoes;
Problem identification	Increased counts in resting box, emergence traps, dip samples;
Causative factors	Excessive plant growth, lack of predators;
Management strategies	Draw water surface down, use biological controls such as fish ( <i>gambusia</i> ), use chemical controls (e.g., Bear oil 1000);
Lead time	2 to 3 weeks, depending on sampling frequency;
Evaluation of control	Reduced larval count.

**Table D5 Operational issue - vegetation control (From Tchobanoglus 1993)**

Item	Objective/action
Operating goal	Process performance;
Problem identification	Clogging of flow paths, odours from decomposition, short-circuiting, low density, poor plant health;
Causative factors	Aggressive growth, lack of vegetative management, excessive water depth, poor water flow patterns, seasonal variation, grazing;
Management strategies	Reduce water depth, soil enhancement, supplemental planting, controlled burns, periodic harvesting;
Lead time	Growing season;
Evaluation of control	Vegetation surveys, vegetation maps, photographic records.

### D.19.3 Process Performance and Control

An important reason for monitoring the performance of Constructed Wetlands is to collect data that can be used to develop process performance and control strategies. A suggested list of monitoring parameters for Constructed Wetlands is presented in Table D6, adapted from Mitsch (1993). The specific parameters that need to be monitored will depend on the design objectives, local conditions, and regulatory requirements. In addition to meeting regulatory reporting requirements, monitoring data should be used to assess process stability and performance, spotting trends before they become problems. If the process is found to be unstable during certain times of the year, corrective measures (such as effluent recycle) can be undertaken to improve the stability of the process.

### D.19.4 Fate of Specific Constituents

Long-term monitoring can be used to define the fate of specific constituents, which, in turn, can be used to define the dynamics of Constructed Wetlands. Long-term data are needed to define the removal, retardation, transformation and movement of specific constituents within the Wetland. This type of information will be needed as Constructed Wetlands are used to meet the restrictive inland water quality standards that are based on specific constituents. For compounds such as heavy metals and refractory organic compounds, it

may become mandatory to know their fate in the Wetland and potential for re-release at some future time.

#### D.19.5 Development of Database

Although it is difficult to get operators to collect anything but the bare minimum operating data, every effort should be made to collect data that can also be used to develop a database on the operation of the system.

#### D.20 Cost of Constructed Wetland Treatment Systems

The cost of Wetland treatment systems is dependent upon the annual and unit cost for the systems should be compared, the cost of land and the labour requirements including management, supervisory and technical demand and training. It has been estimated that Wetlands systems may be as low as 10% of conventional systems designed to meet comparable effluent standards (Cooper 1988).

Green (1994) in reporting on the application of primarily SF Wetlands in the UK with an imported media found the capital costs to be of the order of £100/person equivalent (approximately \$170) for small community applications ie ± 150 people, whilst the unit cost reduced dramatically as the application enlarged ie to ± £40/person equivalent at 1 000 people (approximately \$70/person equivalent). The operational costs were calculated as 1 man day per year or £0,08/person equivalent/yr (approximately \$0.14/person equivalent/yr).

Schultz (1994) reported that US FWS costs, where the systems were generally larger, were typically \$33 750 to \$56 250 per hectare, whilst SF costs were typically \$56 250 to \$78 750 per hectare where suitable on-site medias are available. However, where suitable media required purchasing and haulage to site the unit costs were typically increased to >\$157 500 per hectare. In both cases land costs are excluded.

Table D7 illustrates comparative costs estimated for various Constructed Wetland configurations.

Batchelor (1996 Personal Communication) has provided a summary of a costing schedule for a small community wetland system incorporating subsurface primary beds and surface flow secondary or tertiary beds. The costing can be taken as indicative for South African conditions. The system sizing should accommodate 10 m<sup>3</sup>/d settled sewage with contingency and up to 20 m<sup>3</sup>/d with operational care and consideration.

**Table D6 Monitoring Parameters for Constructed Wetland System**  
(Adapted from Mitsch 1993)

Parameter	Project phase (pre, or during, or construction or ongoing)	Location	Frequency of collection
Water quality*			
Dissolved oxygen	Ongoing	In, out, along profile	Weekly
Hourly dissolved oxygen	Ongoing	Selected locations	Quarterly
Temperature	Pre, during, ongoing	In, out, along profile	Daily/weekly
Conductivity	Pre, during, ongoing	In, out	Weekly
pH	Pre, during, ongoing	In, out	Weekly
BOD	Pre, during, ongoing	In, out, along profile	Weekly
SS	Pre, during, ongoing	In, out, along profile	Weekly
Particle size distribution	Pre, during, ongoing	In, out, along profile	Weekly
Nutrients	Pre, during, ongoing	In, out, along profile	Weekly
Chlorophyll A	Ongoing	Within Wetland, along profile	Quarterly
Metals (Cd, Cr, Cu, Pb, Zn)	Pre, during, ongoing	In, out, along profile	Quarterly
Bacteria (total and faecal coliform)	Pre, during, ongoing	In, out	Monthly
EPA priority pollutants	Pre, during, ongoing	In, out, along profile	Semiannually
Other organic	Pre, during, ongoing	In, out, along profile	Annually
Biotoxicity	Pre, during, ongoing	In, out	Semiannually
Sediments			
Redox potential	Pre, during, ongoing	In, out, along transects	Quarterly
Salinity	Pre, ongoing	In, out, along transects	Quarterly
pH	Pre, during, ongoing	In, out, along transects	Quarterly
Organic matter	Pre, post	In, out, along transects	Quarterly
Biota			
Plankton (zooplankton tow)	Ongoing	Within Wetland, along transects	Quarterly
Invertebrates	Ongoing	Within Wetland, along transects	Quarterly
Fish	Ongoing	Within Wetland, along transects	Quarterly
Birds	Pre, during, ongoing	Within Wetland, along transects	Quarterly
Endangered species	Pre, during, ongoing	Within Wetland, along transects	Quarterly
Mosquitoes	Pre, during, ongoing	Within Wetland, along transects	Weekly during critical months
Wetland development			
Flowrate	Ongoing	Within Wetland, along transects	Continuous
Flowrate distribution	Ongoing	Within Wetland, along transects	Annually
Water surface elevations	Ongoing	Within Wetland, selected locations	Semiannually
Marsh surface elevations	Ongoing	In, out	Quarterly
		Within Wetland	
		Within Wetland	
		Within Wetland	

\* Water quality for pre- and during construction refers to the wastewater that is to be applied to the Wetland.

Ultimately, the database can be used to develop (1) improved process designs for new systems, (2) improved process control measures, (3) improved long-term management strategies, and (4) information that will be of use to the profession.

**Table D7 Relative Comparison of Cost, Operation, and Treatment for Various Constructed Wetland System Configurations**

Configuration	Land Area	Substrate E Cost	Evaluation/ A Grading	Cold Climate Effect	Mosquito Control	Advanced Treatment	Nitrification Enhancement (NO <sub>x</sub> Reduction)	Denitrification Enhancement (N Removal)	Phosphorus Sorption Enhancement	Effluent Dissolved Oxygen
FWS	H	na	L/H	H	L	M	L	L	N	M
SF	L	H	H/L	L	H	M-H	L	L	N-H	L
FWS+SF	M	M	N/M	H	L	M-H	L	L	N-H	L
SF+FWS	M	M	M/M	H	L	M-H	M	L-M	N-H	M
FWS-FWS	H	na	M/M	H	M	M	M-H	L	N	H
FWS-SF	M	M	M/M	H	M	H	H	H	N-H	L
FWS-SF-P	M-H	na	H/H	H	L	M-H	M-H	M	N-H	M-H
SF-P/C-SF	L	H	H/H	L	H	H	H	H	N-H	L
EFF-AIR	L	na	na/L	na	na	na	na	H	na	H

a. Evaluation of soil without major rock.

b. That provided by configuration only, not by operation.

c. BOD and SS effluent concentrations 20 mg/l or less.

d. Dependant on physical and chemical characteristics of SF substrate.

SF = surface flow cell  
 SSF = subsurface flow cell  
 P = pond  
 SF/P = surface flow cell or pond, etc  
 P/C = pond, etc., or cascade.  
 EFF-AIR = effluent aeration  
 H = high  
 M = medium  
 L = low  
 N = none  
 na = not applicable

Table D8 Sub-Surface Flow Wetland (SF) Construction Costs (Batchelor Pers. Comm)

Length	Width	Depth	Flow
20	15	0.6	10 m <sup>3</sup> /d (Design)

## COST SCHEDULE OF QUANTITIES.

COST FACTOR:				
DESCRIPTION	Qty	Units	Rate	Cost
<b>1. EARTHWORKS: Embankment Slopes (W/d):</b>				
1.1 Clear & Grub.	300	m <sup>2</sup>	2.50	750
1.2 Remove topsoil 150mm deep, stockpile for reuse.	300	m <sup>2</sup>	10.00	3 000
1.3 Bulk Excavate for pond Embankment slopes 1:3 & reuse spoil for embankment Berms.	300	m <sup>2</sup>	5.00	1 500
1.4 Trimming & Compacting embankment slopes.	70	m <sup>2</sup>	7.50	525
1.5 Form embankment Berms & compact to 93% MOD AASHTO, including spreading excess spoil.	140	m <sup>3</sup>	35.00	4 900
1.6 Fill in Floors using topsoil 150mm thick & compact to 90% MOD AASHTO.	0	m <sup>3</sup>	3.50	
1.7 Restricted excavation for pipework sluice wall & manhole footing.	15	m <sup>3</sup>	50.00	750
<b>2. SUNDRIES:</b>				
2.1 Bidim U14 impregnated Bitumen Lining.	0	m <sup>2</sup>	12.50	
2.2 Grassing Embankment berms	210	m <sup>2</sup>	4.00	840
2.3 32mm Aggregate Filling in pond	180	m <sup>3</sup>	90.00	16 200
2.4 20/19 Concrete in wall footing & MH Base etc.	5	m <sup>3</sup>	450.00	2 025
2.5 220mm Brickwork wall in stocks	0	m <sup>2</sup>	105.00	
2.6 110mm Brickwork MH in stocks	0	m <sup>2</sup>	75.00	
2.7 Sluice gate including slide grooves	2	m <sup>3</sup>	2 500.00	5 000
2.8 Reinforcing @25 kg/m <sup>2</sup>	0	kg	8	0
<b>3. PIPEWORK 63mm Inside Diameter</b>				
3.1 Inlet Sections	8	m	45.00	360
3.2 Outlet Sections	6	m	45.00	270
3.3 90 degree Bends	4	m	150.00	600
3.4 Trees on 'O'-Rings	2	m	175.00	350
3.5 Perforated Outlet sections Bidim wrapped	15	m	75.00	1 125
3.6 Pumps required Per Unit	0	-	0.00	0
<b>COST FOR SYSTEM WITH UNITS IN PARALLEL</b>		<b>1 UNIT</b>	<b>0 UNITS</b>	
		0	38 195	
Add 25% Contingencies		0	9 549	
		0	0	
7.5% Engineering Fees		0	3 581	
<b>TOTAL COST FOR COMPLETE SYSTEM</b>		<b>0</b>	<b>51 325</b>	



**Table D 9. Surface Flow Wetland (FWS) Construction Costs (Batchelor pers. Comm)**

Length	Width	Depth	Flow
20	15	0.3	10 m <sup>3</sup> /d

**COST SCHEDULE OF QUANTITIES.**

<b>COST FACTOR:</b>				
<b>DESCRIPTION</b>	<b>Qty</b>	<b>Units</b>	<b>Rate</b>	<b>Cost</b>
<b>1. EARTHWORKS: Embankment Slopes (W/d):</b>				
1.1 Clear & Grub.	300	m <sup>2</sup>	2.50	750
1.2 Remove topsoil 150mm deep, stockpile for reuse.	300	m <sup>3</sup>	10.00	3 000
1.3 Bulk Excavate for pond Embankment slopes 1:3 & reuse spoil for embankment Berms.	300	m <sup>3</sup>	5.00	450
1.4 Trimming & Compacting embankment slopes.	70	m <sup>2</sup>	7.50	525
1.5 Form embankment Berms & compact to 93% MOD AASHTO, including spreading excess spoil.	140	m <sup>2</sup>	35.00	4 900
1.6 Fill in Floors using topsoil 150mm thick & compact to 90% MOD AASHTO.	0	m <sup>2</sup>	3.50	
1.7 Restricted excavation for pipework sluice wall & manhole footing.	15	m <sup>3</sup>	50.00	750
<b>2. SUNDRIES:</b>				
2.1 Bidim U14 impregnated Bitumen Lining.	0	m <sup>2</sup>	12.50	
2.2 Grassing Embankment berms	210	m <sup>2</sup>	4.00	840
2.3 32mm Aggregate Filling in pond	0	m <sup>3</sup>	90.00	
2.4 20/19 Concrete in wall footing & MH Base etc.	1	m <sup>3</sup>	450.00	607
2.5 220mm Brickwork wall in stocks	0	m <sup>2</sup>	105.00	
2.6 110mm Brickwork MH in stocks	0	m <sup>2</sup>	75.00	
2.7 Sluice gate including slide grooves	2	m <sup>3</sup>	2 500.00	5 000
2.8 Reinforcing @25 kg/m <sup>2</sup>	0	kg	8	0
<b>3. PIPEWORK 63mm Inside Diameter</b>				
3.1 Inlet Sections	8	m	45.00	360
3.2 Outlet Sections	6	m	45.00	270
3.3 90 degree Bends	4	m	150.00	600
3.4 Trees on 'O'-Rings	2	m	175.00	350
3.5 Perforated Outlet sections Bidim wrapped	15	m	75.00	1 125
3.6 Pumps required Per Unit	0	-	0.00	0
<b>COST FOR SYSTEM WITH UNITS IN PARALLEL</b>		<b>1 UNIT</b>	<b>0 UNITS</b>	
Add 25% Contingencies		0	19 528 4 882	
7.5% Engineering Fees		0	0 1 831	
<b>TOTAL COST FOR COMPLETE SYSTEM</b>		<b>0</b>	<b>26 240</b>	

## BIBLIOGRAPHY

- Adcock, P W, *et al*, 1994. Nutrient Partitioning in a Clay - Based Surface Flow Wetland. Pres 4th Int. Conf. Methods in Water Pollution Control. Ghangzhou, People's Republic of China.
- Alexander, W V, *et al*, 1987. Experimental Investigation into the use of Emergent Plants to Treat Sewage in South Africa. *Wat. Sci. Tech.*, 19 (10), 51-59.
- Armstrong, W. 1990. Measurements and Modelling of Oxygen Release from Roots of *Frogmouths australis*. Pres. Int. Conf. Wetlands in Water Pollution Control. Cambridge, England. Sept 24-28.
- Armstrong, W; *et al*, 1990, Measurement; modelling of oxygen release from roots of *frogmouths australis*. Proc. Int. Conf, on the Use of Constructed Wetlands in Water Pollution Control, Pergamon Press 41 - 52
- Aulenbach, D B, *et al*, 1988 Studies on the mechanism of phosphorus removal from treated wastewater by sand. *J.W.P.C.F.* Vol 60.12 2089-2094
- Bahgat, M M M. 1994. The Abu-Attwa Gravel Bed Hydroponic (GBH) for Sewage treatment. The Egyptian Experience. IAWQ. Specialist Group. Macrophytes in Water Pollution Control. Newsletter. May IAWQ London.
- Batchelor, A, *et al*, 1994. Recent advances in constructed wetland technology. *Wat.Sew.Eff.* 14 (2) 9-16
- Batchelor, A, *et al*, 1990. Constructed Wetland Research Programme in South Africa. In *Constructed Wetlands - Water Pollution Control*. P F Cooper Ed Pergamon Press. Oxford, UK.
- Batchelor, A, *et al*, 1996. A Critical Evaluation of a Pitot Scale Subsurface Flow Wetland: 10 years. After Commission. Pres, 5th Int. Conf. Wetlands Water Pollution Control. Vienna. September. 15-19.
- Bavor, H J. 1994. Challenges for Development in Advanced Constructed Wetlands Technology. Proc 4th Int Conf on Wetland System for Water Pollution Control. Nov 1994.
- Bavor, H J, *et al*, 1992. Nutrient removal and disinfection performance on the Byron Bay Constructed Wetland System. In: *Constructed Wetlands in Water Pollution Control*: Ed. H J Bavor. Pergamon Press, London.
- Bercic, O U, *et al*, 1994. Integrated Constructed Wetland for Small Communities. 4th Int Conf on Wetland System for Water Pollution Control. Nov 1994.

- Boon, AG. 1985. Report of a visit by members and staff of WRC to Germany (FRG) to investigate the root zone method for treatment of wastewaters. WRC Report 376 S, Stevenage, August 1985 (revised in February 1986)
- Breen, P F, *et al*, 1994. Artificial Wetlands Treating Wastewater- Rootzone Conditions and System Performance -a Comparison of Vertical and Horizontal Flow Systems. Pres 4th Int. Conf. Methods in water Pollution Control. Guangzhou, People's Republic of China
- Breen, P F, *et al*, 1994. Rootzone Dynamics in Constructed Wetlands Receiving Wastewater: A Comparison of Vertical and Horizontal Flow Systems. Pres. 4th International Specialist Conference on Wetland Systems and Water Pollution Control. Guangzhou, People's Republic of China.
- Brix, H. 1987. Treatment of Waste water in the Rhizosphere of Wetlands Plants - The Root Zone Method. *Wat. Sci. Technol.* 19 R10 107-118.
- Brix, H. 1992. Functions of Macrophytes in Constructed Wetlands. Pres. Int. Conf. Wetlands in Water Pollution Control. H J Bavor Pergamon Press, London.
- Brix, H. 1993. Wastewater treatment in Constructed Wetlands. System design, removal processes and treatment performance. In *Constructed Wetlands for Water Quality Improvement*. Ed. G A Moshir, CRC Press Inc. Boca Raton, Florida.
- Bucksteeg, K. 1987. Discussion of treatment of wastewaters in the rhizosphere of wetland plants - the root zone method. - H Brix. *Water Science and Technology*, 19, p1063, 1987.
- Burka, U, *et al*, 1990. A new community approach to wastewater treatment with higher water plants, p359 in *Constructed Wetlands in Water Polluting Control* (PF Cooper and BC Findlater (Eds)). Pergamon Press, Oxford, UK, 1990.
- Butler, J E, *et al*, 1990, Design, construction, establishment and operation of gravel bed hydroponic (GBH) systems for secondary, tertiary sewage treatment. Pros. Int. Conf. on the use of constructed wetlands in water pollution control. Pergamon Press 539-542
- Butler, J E, 1991. Gravel bed hydroponic systems (GBH) for sewage treatment. Proceedings of African Regional Symposium on Techniques for Environmentally Sound Water Resources Development. Pentech Press, London. pp 96 - 105
- Butler, J E, *et al*, 1992. Gravel Bed Hydroponics - A Method of Wastewater Treatment and Crop Production. ISOSC Proceedings. 97-113.

- Butler, J E, *et al*, 1990, Gravel bedhydroponic systems used for secondary and tertiary treatment of sewage effluent. *J. IWEM*. 4(3), 276-284
- Conley, L M. 1991. An Assessment of the Root Zone Method of Wastewater Treatment. *Research Journal. WPCF*. 63:239-247.
- Conway, T E. 1988. The Iselin Marsh pond Meadow. *Pres. int. conf Constructed Wetlands in Water Pollution Control. Chattanooga, Tennessee June 13-17 1988.*
- Coombes, C. 1990. Reed Bed Treatment Systems in Anglian Water. In. *Constructed Wetlands in Water Pollution control*. Ed. P F Cooper and B C Findlater, Pergamon Press.
- Cooper, J D. 1986. Measurement of Hydraulic Conductivity for Root-zone Sewage Treatment Beds. *Inst. Hydrology - Recommendations to Water Research Centre, April.*
- Cooper, P F, *et al*, 1994. Reed Bed Treatment Systems for Sewage Treatment in the United Kingdom: the First 10 Years Experience. *Proc 4th Int Conf on Wetland System for Water Pollution Control. Nov 1994.*
- Cooper, P F. 1993 The use of Reed Bed Systems to treat domestic sewage: the European Design and Operations Guidelines for Reed Bed Treatment Systems. p203-217 in *Constructed Wetlands for Water Quality Improvement*. G Moshiri (Ed.). Lewis Publishers, Boca Raton, Fla, USA. 1993.
- Cooper, P F, *et al*, 1987. The Use of *frogmouths* for Wastewater Treatment by the Root Zone Method. "Aquatic Plants for Water Treatment and Resource Recovery". (Ed. K R Reddy).
- Cooper, P F, *et al*, 1989. Sewage treatment by reed bed systems. *J. IWEM*,3 (1), 60 - 40
- Cooper, P F, 1990. EC/EWDCA Design Guidelines. *Pres. Int. Conf. Use of Constructed Wetlands in Water Pollution Control. England, 24 - 28 September.*
- Crites, R W, 1992. Design Criteria and Practice for Constructed Wetland. *Pres Int Conf Wetlands in Water Pollution Control. Sydney, Australia. Nov 30-Dec 3.*
- Cueto, A J, 1992. Development of Criteria for the Design and Construction of Engineered Aquatic Treatment Units in Texas. In Moshiri G A Ed. *Constructed Wetlands for Water Quality Improvement*. Lewis Pub. Ann Arbor.
- Davies, T H, 1988. Reed Bed Treatment of Wastewaters. *An European Perspective. Water, Sydney 15, 32-33+39.*

- Davies, T H, 1992. The Use of Constructed Wetlands for Treating Industrial Effluents. Pres. Int. Conf. Wetlands in Water Pollution Control. Sydney, Australia. Nov30-Dec 3.
- EPA, 1988. Constructed Wetlands and Aquatic Plant Systems for Municipal Wastewater Treatment. EPA 625/1-88/022. Cincinnati, OH.
- EPA, 1993. Subsurface Flow Constructed Wetlands for Wastewater Treatment. A Technology Assessment EPA 832-R-93-008.
- European Design and Operations Guidelines for Reed Bed Treatment Systems, 1990. Cooper, P F ed, EC/EWPCA Emergent Hydrophyte Treatment Systems Expert Contact Group, WRc Swindon, Swindon, England, A-5, 1990.
- Fourie, A B, *et al*, 1994. Some lessons learned from the use of artificial wetlands for treating acid mine drainage. Proc 3rd Int Conf Env Issues and Waste Management in Energy and Minerals Production.
- Green, M B. 1993. Growing confidence in the use of constructed reeds beds for polishing wastewater effluents. Proceedings of Water Environment Federation. 66th Annual Conference and Exposition. General Topics, Vol 9, p86-98.
- Green, M B. 1993. Reedbed Treatment for Small Communities - UK Experience. In Constructed Wetlands for Water Quality Improvement. Ed GA Moshiri. Lewis Pub.
- Green, M B, *et al*, 1994. Constructed reed beds: A cost effective way to polish wastewater effluents for small communities. Water Environmental Research, Vol 66 (3), p188-192.
- Haberl, R. 1990. Seven Years of Research Work and Experience with Wastewater Treatment by a Reedbed System. Pres. Int. Conf. Wetlands in Water Pollution Control. Cambridge, England. Sep 24-28.
- Hammer, D A, *et al*, 1992. Designing Constructed Wetlands for Nitrogen Removal. In Wetlands in Water Pollution Control. Ed. H J Bavor, Pergamon Press, London.
- Hammer, D A. 1994.. Designing Constructed Wetlands for Nitrogen Removal. Wat. Sci. Tech 29(4) 15-27.
- Healey, K J, *et al*, 1988. The Operation of an Artificial Reed Bed at the Mpophomezi Sewage Treatment Works. Seminora Water supply and Sanitation. Kwazulu. IWSA Elangeni Hotel, Durban 28-30 June.
- Hensman, L C. 1985. The use of algae for the removal of phosphorous from secondary wastewater effluents. Ph D thesis. University of Pretoria.

- Hiley, P D, 1990. The Reality of Sewage Treatment Using Wetlands. Pres Int. Conf. Wetlands in Water Pollution Control. Cambridge, England. Sep 24-28.
- Hu, KP, *et al*, 1994. Design of Sub-Surface Flow Constructed Wetland Systems. Pres 4th Int. Conf. Methods in water Pollution Control. Guangzhou, People's Republic of China.
- Jensen, A, *et al*, 1992. Presentation and Management of Natural Wetlands in the south Australian Murray Valley. In: Wetlands on Water Pollution Control. Ed. H J Bavar Pergamon Press, London.
- Jensen, A, *et al*, 1994. Cold- Climate Constructed Wetlands. Pres 4th Int. Conf. Methods in water Pollution Control. Guangzhou, People's Republic of
- Kadlec, R H, 1989. Hydrologic Factors in Wetland Treatment. In: Constructed Wetlands in Wastewater Treatment. Ed. DA Hammer. Lewis Press. MI373.
- Kadlec, R H, 1991. Engineering Aspects of Constructed Wetland Systems: An Engineering Perspective of Biological Challenges. Pres. Int. Conf. Wetlands in Water Pollution Control. Sydney, Australia. Nov 30-Dec 3.
- Kadlec, R H, 1992. Hydraulic Design of Free Water Surface Treatment Wetlands. In Moshiri G A Ed. Constructed Wetlands for Water Quality Improvement. Lewis Pub. Ann Arbor.
- Kadlec, R H, 1992. Engineering Aspects of Constructed Wetland Systems: An Engineering Perspective of Biological Challenges. Pres. Int. Conf. Wetlands in Water Pollution Control. Sydney, Australia. Nov 30-Dec 3.
- Kadlec, R H, 1993. Hydraulic and solids accumulation in gravel bed treatment system. In. Constructed Wetlands in Water Quality Improvement. Ed. G. Moshiri, CNC Press. Boca Ratan, Florida.
- Kikuth, R. 1984. Application of the root zone process. *Landschaft & Stadt*, 16 (3), 145 - 153.
- Knight, R L *et al*, 1990. Design of the Fort Deposit, Alabama. Constructed Wetland Treatment System. In: Constructed Wetlands in Water Pollution Control. Ed. P F Cooper. Pergamon Press, London.
- Knight, R L. 1992. Wetlands for Wastewater Treatment Data Base. Pres. Int. Conf. Wetlands in Water Pollution Control. Sydney, Australia. Nov 30 - Dec 3.
- Lawson, G J, 1985. Cultivation reeds/*Phragmites australis*, for root zone treatment of sewage. Contract report ITE project, WRc Processes

- Loveridge, R F, 1993. Secondary and Tertiary Treatment of Sewage in Egypt Using Artificial Wetlands and Gravel Beds. Water Africa Conference, Johannesburg. October.
- Mann, R A, 1990. Phosphorus removal by Constructed Wetlands. Substratum adsorption. In: Constructed Wetlands in Water Pollution Control. Ed. P F Pergamon Press, London.
- Mitchell, D S, *et al*, 1994. The Use of Wetlands for Water Pollution Control in Australia: an Ecological Perspective. Pres 4th Int. Conf. Methods in water Pollution Control. Guangzhou, People's Republic of China
- Netter, R. 1992. Flow Characteristics of Planted Soil Filters. In Moshiri G A Ed. Constructed Wetlands for Water Quality Improvement. Lewis Pub. Ann Arbor.
- Netter, R. 1994. 10 Years Experience with the Use of the Planted Soil Filter at See (Germany) for the Treatment of Septic Tank Effluent. Pres 4th Int. Conf. Methods in water Pollution Control. Guangzhou, People's Republic of China..
- Norris, G. 1993. STED a viable and cheaper alternative to waterborne sewerage. NMOD Nov 17-21.
- Parr, T W. 1987. Experimental studies on the propagation and establishment of reeds (*Frogmouths australis*) for root zone treatment of sewage. Contract report no. T08018el to WRc. Institute of Terrestrial Ecology, Monks Wood experimental Station, Hatfield. November 1987.
- Parr, TW. 1989. Management of reeds in reed bed treatment systems. Contract report No.T08018il to WRc. Institute of Terrestrial Ecology, Monks Wood Experimental Station, Hatfield. March 1989.
- Reed, S, *et al*. 1988. Natural Systems for Wastewater Management Treatment. McGraw-Hill, New York.
- Reed, S C, 1990. An Inventory of Constructed Wetlands Used for Wastewater Treatment in the United States. Prepared for USEPA RREL, Cincinnati, OH,
- Reed, SC, 1992. Constructed Wetland Design: The First Generation. Wat. Env. Res. 64-6-776-781.
- Richardson, C. J. 1985. Mechanisms controlling phosphorous retention capacity in freshwater wetlands. Science 228 1424-7.
- Rivera, F. *et al* 1994. Removal of Pathogens from Waste water by the Root Zone Method (RZM) Pres 4th Int. Conf. Methods in water Pollution Control. Guangzhou, People's Republic of China.

- Rogers, F E H, 1985. Wetlands for Wastewater Treatment with special reference to Municipal Wastewaters. Witwatersrand Univ, Press Johannesburg, RSA.
- Rogers, F E H, *et al*, 1985, Wetlands for Wastewater Treatment using aquatic plants and artificial wetlands. Water, Sydney 14 (3) 20-4.
- Rogers, K H, *et al*, 1990. Hydraulics, Root Distribution and phosphorous removal in experimental wetland systems. Pres Int conf Constructed Wetlands in Water Pollution Control. Cambridge, England. Sept.
- Rogers, K H, *et al*, 1991. Nitrogen removal in experimental wetland treatment systems: Evidence for the role of aquatic plants. Res. Journal. WPCF. 63(7)934-941.
- Seidel, K, *et al*, 1976. Macrophytes and water purification. In Biological Control of Water Pollution. Edited by Tourbier, J. & Pierson, R.W.). University of Pennsylvania Press, pp 109-121.
- Slater, N P, *et al*, 1990. Artificial Wetlands. A process and Performance Overview. Umgeni Water. Pietermaritzburg. R.S.A.
- Steiner, J T, *et al*, 1993. General Designs, Construction and Operation Guidelines for Small Constructed Wetlands, Wastewater Treatment Systems. In Constructed Wetlands for Water Quality Improvement. Ed. G A Moshiri Lewis Publishers.
- Tchobanoglous, G, *et.al* 1980, Wetlands Systems for Wastewater Treatment: An Engineering Assessment. US Environmental Protection Agency, Office of Water Programme Operations, Series Water EPA 430/9-80-007, Washington DC
- Tchobanoglous, G.1980, Wetlands Systems for Wastewater Treatment: US EPA 430/9-80-007 Washington DC, USA.
- Tchobanoglous, G, *et.al* 1992, Constructed Wetlands and Aquatic Plant Systems: Research, Design, Operation and Monitoring Issues. In Moshiri G A Ed. Constructed Wetlands for Water Quality Improvement, Lewis Pub. Ann Arbor.
- van der Merwe, C G, *et al*, 1990. Observations on concentrations of heavy metals, Zn, Mn, Ni, Fe in the water, sediments and aquatic plants, *Typha capensis* and *Arundo donax* of a stream affected by goldmine and industrial effluent. Water SA, 19(2) 119-124.
- van der Walt, *et al*, 1995. A Reedbed system for secondary treatment of a mixed effluent. Pres Biotechnology for Africa. Univ Pretoria, 13-15 Nov.
- van Oostrom, A J, 1994. Nitrogen Removal in Constructed Wetlands Treating Nitrified Meat Processing Wastewater. Pres 4th Int. Conf. Methods in water Pollution Control. Guangzhou, People's Republic of China.



- Vymazal, J. Constructed Wetlands for Wastewater Treatment in the Czech Republic -State of the Art. Pres 4th Int. Conf. Methods in water Pollution Control. Guangzhou, People's Republic of China.
- Wang, J S, *et al*, 1994. Analysis of the configuration and the Treatment Effect of Constructed Wetland Wastewater Treatment System for Different Wastewaters in South China. 4th Int Conf on Wetland System for Water Pollution Control. Nov 1994.
- Water Pollution Control Federation (WPCF), 1990. Manual of Practice, Natural Systems for wastewater Treatment. FD-16 Washington DC, USA.
- Williams, J B, *et al*, 1992. Nitrogen Transformations in Gravel Bed Hydroponic Beds used as a Tertiary Treatment Stage to Sewage Treatment. Pres. Int. Conf. Wetlands in Water Pollution Control. Sydney Australia. Nov 30-Dec 3.
- Williams, J B *et al* 1992. Microbial mechanisms operating in gravel bed hydroponic beds used as a tertiary treatment stage for sewage effluents Proc. IAWQ Conf. on wetland systems in water pollution control, Sydney, Australia. Nov 30 - Dec 3.
- Williams, J, *et al*, 1994. The Removal of Pathogenic Microorganisms during Sewage Treatment in Gravel Bed Hydroponic Constructed Wetlands. Pres 4th Int. Conf. Methods in water Pollution Control. Guangzhou, People's Republic of China.
- WISA 1988. Manual on the Design of Small Sewage Works. Water Institute of Southern Africa. Johannesburg, South Africa.
- Wong, M H, *et al*, 1994. Reclamation of Polluted Riverwater for Aquaculture of Nutrients by Microalgae. 4th Int Conf on Wetland System for Water Pollution Control. Nov 1994.
- Wood, A, *et al*, 1988. Research to develop engineering guidelines for the implementation of constructed wetlands for wastewater treatment in Southern Africa. Pres. Int. Conf. Wetlands in Wastewater Treatment. Chattanooga, Tennessee, June 13-17.
- Wood, A, 1990. Constructed Wetlands for Wastewater Treatment - Engineering and Design Considerations. Pres Int Conf Use of Constructed Wetlands in Water Pollution Control. Cambridge, England. 24-28 September.
- Wood,, A, 1991. Application of Constructed Wetlands for Wastewater Treatment in South Africa. Pres. WISA Biennial Conference, Kempton Park, May 13-15.
- Wood, A. 1994. Constructed Wetland in Water Pollution Control: Fundamental to their Understanding. Proc 4th Int Conf on Wetland System for Water Pollution Control. Nov 1994.

- Wood, A, 1994. Constructed Wetlands in Water Pollution Control. Fundamentals to their Understanding. Pres. Int. Conf. Constructed Wetlands in Water Pollution Control. Guangzhou, People's Republic of China
- Wood, A, 1996. Investigation into the Application and Performance of Constructed Wetlands for Waste Water Treatment in South Africa. Pres, W.I.S.A. Biennial Conference, Port Elizabeth. May.
- WRC, 1990. European Design and Operational Guidelines for Reedbed Treatment Systems. WRC Report UI 17 Stevenage, England.
- Wrigley, T J *et al*, 1988. The ability of an artificially established wetland system to upgrade oxidation pond effluent to meet water quality criteria. *Water SA*, 14(4) 171-177.
- Yang, P Y, *et al*, 1994. A Small Wastewater Treatment Alternative for a Moderately Land Limited Requirement in the Tropics. Yang, P Y, Chen, H. Pres 4th Int. Conf. Methods in Water Pollution Control. Guangzhou, Peoples Republic of China.
- Yang, P Y, *et al*, 1994. Removal Efficiency of the Constructed Wetland Wastewater Treatment System at Bainikeng. 4th Int Conf on Wetland System for Water Pollution Control. Nov 1994.