

DESIGN, CONSTRUCTION, OPERATION AND MAINTENANCE
OF
VENTILATED IMPROVED PIT TOILETS IN SOUTH AFRICA

Report to the Water Research Commission

by

J W Bester and L M Austin
CSIR Building and Construction Technology, Pretoria

WRC Report No. 709/1/00
ISBN No. 1 86845 647 1

Executive Summary

This report emanates from the Water Research Commission project number K5/709 entitled "Preparation of standard engineering drawings, specifications and guidelines for ventilated improved pit latrines in South Africa".

At present, Ventilated Improved Pit (VIP) toilet systems installed in South Africa are constructed according to a wide variety of designs and with many different types of materials, with a corresponding diversity of performance level and user acceptability. Some designs are of a good standard, but many toilets have been installed which do not function properly and are therefore unpleasant to use. Fly control is often inadequate and factors such as poor construction, high temperatures and bad odours can contribute to negative user experience and subsequent perceptions of the systems as second-rate or inferior.

It is generally accepted that the government cannot afford to provide conventional waterborne sanitation to all communities lacking this facility, at least for the foreseeable future. The majority of communities are also not in a position to provide or maintain such systems themselves. However, because of the strong link between sanitation services and public health, it is imperative that a programme which encourages an adequate basic level of sanitation, which is also largely affordable, be actively pursued in order to reach the communities who have little or no sanitation facilities.

Although it is clear that VIP toilets, correctly designed and constructed, offer an affordable and practical sanitation option to the majority of rural and peri-urban communities, there remains much ignorance regarding the proper engineering of VIP toilets. The authorities responsible for commissioning sanitation programmes, as well as various funding agencies involved in such schemes, do not always have at their disposal the necessary tools to enable them to make informed decisions or choices and consequently are often left with a legacy of poorly engineered sanitation systems. Guidelines for the design and construction of VIP toilets will assist such organizations in setting acceptable minimum standards.

The original aim of this project was to improve the standard of VIP toilets in South Africa by providing responsible organizations with the necessary information to enable them to plan, design, construct and maintain VIP toilets in an effective and sustainable manner. Hence, the following documents were intended to form part of this project:

- Research report (this document)
- Various guideline documents:
 - (a) Design and construction guidelines for domestic VIP toilets
 - (b) Guidelines for local water and sanitation committees on domestic VIP toilets
 - (c) Guidelines for users of domestic VIP toilets.

However, due to the length of time which elapsed, as well as various other eventualities, the guideline documents as stated above have not been completed as part of this project. Guideline (a) has been replaced by a document entitled "Building VIPs: Guidelines for the design and construction of domestic Ventilated Improved Pit toilets". This document, published and distributed by the Department of Water Affairs and Forestry, is based largely on the research carried out as part of this project. Guideline (b) was eventually considered as being superfluous due to the existence of other documents of a similar nature. An attempt was made to produce Guideline (c), but due to the differing interpretations of illustrations, etc by various illiterate or semi-literate communities in the country, it was concluded that it would not be feasible to produce a document of this nature which would be applicable countrywide. It is suggested, rather, that each project be evaluated on its merits and suitable posters or other explanatory materials produced for the specific communities by involving them in the actual process.

The output of this project, as far as the Water Research Commission's original contract with CSIR Building and Construction Technology is concerned, is therefore only this research report.

Issues that were identified as being of cardinal importance for community acceptance of VIP toilets are as follows.

- design and construction issues
- social issues
- environmental and health issues

Particular attention was paid to these aspects during the research phase of the project.

The research report includes a brief introduction to personal hygiene, which highlights the health dangers inherent in human faeces and the importance of using toilets and of washing hands. The disease-carrying role of flies is also pointed out. It is further emphasised that three integral factors, which must coexist, are of importance in promoting community health, namely:

- safe water supplies
- adequate sanitation facilities
- correct disposal of refuse.

The operational principles of both VIP and VIDP toilets are discussed in detail, covering important factors such as proper ventilation as well as fly and odour control. This is followed by a number of illustrated examples of VIP toilet designs from Botswana, Zimbabwe, Lesotho, Tanzania and Brazil, as well as various South African examples. An in-depth discussion of research findings and recommendations regarding the various components of a VIP toilet is then presented, covering the following aspects:

- substructure (i.e. the pit)
 - location
 - capacity
 - lining
 - collar
- pit cover slab
 - materials
 - orientation
- superstructure
 - location and orientation
 - materials
 - door
 - walls
 - roof
 - ventilation openings
- seat or pedestal
 - types
 - materials
- vent pipe
 - purpose
 - materials
 - size and performance
 - orientation
- fly screen
 - purpose
 - materials
 - fixing
- hand-washing attachments

Regular maintenance of VIP toilets is essential if they are to continue functioning as they should and remain in an attractive and acceptable condition for use. The research report emphasises cleanliness and prompt attention to matters such as fixing of cracks, termite control, stormwater diversion, fly screen care, treatment of doors and hinges, as well as mosquito control. Factors affecting the rate of solids accumulation are listed and attention is drawn to the fact that disinfectants should not be put into the pit.

Pit emptying is often a problem if toilets are not specifically designed to facilitate the process. While mechanical emptying may be a solution in some urban areas, it is rarely an option in rural areas, and also has certain construction implications.

Finally, the issue of population density and its implications for choice of sanitation technology is addressed. The literature yielded certain guidelines on maximum population densities for single pit and twin pit toilets; however, attention is drawn to the problem of progressive loss of ventilation as the number of dwellings increases.

In conclusion it is stated that the Ventilated Improved Pit Toilet, when correctly designed, operated and maintained, has proved to be an acceptable, cost-effective, hygienic and environmentally friendly sanitation system. While there are always certain disadvantages associated with any sanitation technology, if the required attention is paid to all the diverse aspects involved, particularly the social and cultural aspects, then there is no reason why VIP toilets should not become perfectly acceptable to the vast majority of people who do not presently enjoy the benefits of a well designed and constructed toilet.

It is recommended that the Water Research Commission disseminates these findings to all organizations involved in the provision of sanitation. It is further recommended that the Commission actively supports the guideline document for design and construction of VIP toilets distributed by the Department of Water Affairs and Forestry, as these guidelines are a direct outcome of this research project.

During the course of the research project it became evident that certain aspects of VIP toilet technology are in need of further research, as the information available was either scanty or inconclusive. The two most important aspects requiring further investigation are:

- the role of enzymes and bacteria in the operation and maintenance of pits; and
- the minimum required depth of intact, unsaturated soil between the pit and the groundwater in order to prevent contamination.

Acknowledgements

A steering committee was appointed to assist and guide the work being done on this report comprising the following persons:

- Dr N.P. Mjoli Water Research Commission
- Mr H.C. Chapman Water Research Commission
- Mr G.D. Hefer Department of Water Affairs & Forestry
- Mr S. Hartley Department of Water Affairs & Forestry
- Mr M. Rall Mvula Trust
- Mr J. Harrison Durban Wastewater Management
- Mr B. Jackson Development Bank of Southern Africa
- Mr J.J.A. Nel Department of Health
- Mr W.G. Johannes Africon
- Mr G. Norris CSIR Building and Construction Technology
- Mr F.P. Marais Water Research Commission (committee secretary)

The assistance of these persons is acknowledged and appreciated.

The research included a number of interviews with persons and organisations involved in the provision of sanitation facilities, namely:

- Don Crawford (Institute of Natural Resources)
- James Rivett-Carnac (Appropriate Technology Information)
- David Still (Partners in Development CC)
- Barry Jackson (Development Bank of South Africa)
- Martin Rall (Mvula Trust)
- Daniel Carter (Mvula Trust)
- Isabel Blackett (UNICEF consultant to Department of Water Affairs and Forestry)

Their cooperation added to the value of the project and this is also acknowledged.

The project team included:

- L.M. Austin CSIR Building and Construction Technology
- J.W. Bester CSIR Building and Construction Technology
- A. Murdoch CSIR Building and Construction Technology
- E. Pascolo CSIR Building and Construction Technology

This project was funded by the Water Research Commission.

List of Illustrations

Figure 6.1	Operational principles of the VIP toilet	6
Figure 7.1	The Reed Odourless Earth Closet	9
Figure 7.2	The BOTVIP	10
Figure 7.3	A schematic diagram of the BOTVIP	11
Figure 7.4	The rural VIP toilet in Zimbabwe	12
Figure 7.5	The rural VIP toilet in Zimbabwe (exploded)	13
Figure 7.6	Photo of the ferrocement spiral VIP toilet in Zimbabwe	14
Figure 7.7	Exploded schematic diagram of the ferrocement spiral VIP toilet	15
Figure 7.8	Photo of the brick spiral VIP toilet in Zimbabwe	16
Figure 7.9	The brick spiral VIP toilet in Zimbabwe	17
Figure 7.10	The Blair latrine (One bag model)	18
Figure 7.11	The Blair latrine (Standard model)	19
Figure 7.12	The SanPlat latrine	21
Figure 7.13	The urban VIP toilet in Tanzania	23
Figure 7.14	The urban VIP toilet in Brazil	24
Figure 7.15	The REC II VIDP latrine	25
Figure 8.1	Typical pit linings	31
Figure 8.2	Typical pit collars	32
Figure 10.1	Typical VIP toilet superstructures	36

Table of Contents

Executive Summary	i
Acknowledgements	iv
List of Illustrations	v
Table of Contents	vi
1. Background	1
2. Aims of the project	2
3. Methodology	2
3.1 General	2
3.2 Approach adopted	3
4. Personal hygiene	4
5. Defects of ordinary pit toilets	4
6. Operational principles of Ventilated Improved Pit (VIP) toilets	5
7. Examples of different VIP toilets	8
8. Substructure	27
8.1 General	27
8.2 Location	27
8.3 Pit capacity	27
8.4 Pit lining	29
8.5 Pit collar	30
9. Cover slabs	33
9.1 General	33
9.2 Orientation	34
10. Superstructure	34
10.1 General	34
10.2 Location and orientation	37
10.3 Walls	38
10.4 Door	38
10.5 Roof	39
10.6 Ventilation opening	39
11. Seat	40
12. Vent pipe	41
13. Fly screen	44
14. Hand-washing attachments	44
15. Groundwater pollution	44
16. Maintenance	45
17. Solids accumulation	47
18. Pit emptying	47
19. Plot size and population density	48
20. Conclusions	49
21. Recommendations for further research	49
22. References	50

1. Background

At present, Ventilated Improved Pit (VIP) toilet systems installed in South Africa are constructed according to a wide variety of designs and with many different types of materials, with a corresponding diversity of performance level and user acceptability. Some designs are of a good standard, but many toilets have been installed which do not function properly and are therefore unpleasant to use. Fly control is often inadequate and factors such as poor construction, high temperatures and bad odours can contribute to negative user experience and subsequent perceptions of the systems as second-rate or inferior. The result is all too often that communities, adults and children alike, prefer to use the bush.

It is generally accepted that the government cannot afford to provide conventional waterborne sanitation to all communities lacking this facility, at least for the foreseeable future. The majority of communities are also not in a position to provide or maintain such systems themselves. However, because of the strong link between sanitation services and public health, it is imperative that a programme which encourages an adequate basic level of sanitation, which is also largely affordable, be actively pursued in order to reach the communities who have little or no sanitation facilities. The question of what constitutes adequate sanitation has been defined in the White Paper on Water Supply and Sanitation Policy, November 1994⁽²⁾, as follows:

"The immediate priority is to provide sanitation services to all which meet basic health and functional requirements including the protection of the quality of both surface and underground water. Higher levels of service will only be achievable if incomes in poor communities rise substantially. Conventional waterborne sanitation is in most cases not a realistic, viable and achievable minimum service standard in the short term due to its cost. The Ventilated Improved Pit latrine (VIP), if constructed to agreed standards and maintained properly, provides an appropriate and adequate basic level of sanitation service. Adequate basic provision is therefore defined as one well-constructed VIP latrine (in various forms, to agreed standards) per household."

It is therefore clear that VIP toilets, correctly designed and constructed, offer the only affordable and practical sanitation option to the majority of rural and peri-urban communities. Unfortunately, however, there remains much ignorance regarding the proper engineering of VIP toilets, which has led to the large-scale disillusionment referred to earlier. The authorities responsible for commissioning sanitation programmes, as well as various funding agencies involved in such schemes, do not always have at their disposal the necessary tools to enable them to make informed decisions or choices and consequently are often left with a legacy of poorly engineered sanitation systems. Guidelines for the design and construction of VIP toilets will assist such organizations in setting acceptable minimum standards.

2. Aims of the project

The advantages of well-constructed VIP toilets have been demonstrated in several countries, notably Lesotho and Zimbabwe, and many national and regional sanitation programmes have been successfully launched using this technology. The aim of this project is to improve the standard of VIP toilets in South Africa by providing responsible organizations with the necessary information, which will enable them to plan, design, construct and maintain VIP toilets in an effective and sustainable manner. Towards this end, a rationalised set of guideline documents were envisaged which would hopefully be accepted countrywide as the minimum requirements for properly engineered and maintained VIP toilets.

The following documents were intended to form part of this project:

- Research report (this document)
- Three guideline documents:
 - i. Design and construction guidelines consisting of drawings and specifications for domestic VIP latrines.
 - ii. Guidelines for local water and sanitation committees covering aspects such as sludge build up rates, pit emptying methods, disposal options, etc. Illustrations, showing different domestic VIP latrines to assist the committee in deciding which VIP should be used, are included.
 - iii. Guidelines for users of VIP latrines describing the operation of a VIP toilet as well as simple, routine maintenance tasks. It also emphasises the link between the personal hygiene aspect of toilet use and family health.

The design and construction guidelines were completed and published by the Department of Water Affairs and Forestry in August 1997, and not under the auspices of the Water Research Commission. No other guidelines were produced in terms of this contract.

3. Methodology

3.1 General

Emanating from the stated aims of the project, the following issues have been identified as important factors contributing to the general acceptability or otherwise of VIP toilet sanitation schemes:

- i. Design and construction issues
 - odour
 - safety
 - comfort
 - ventilation
 - temperature
 - light
 - stormwater
 - fly control
 - location
 - pit size
 - pit lining
 - pedestal
 - slab
 - superstructure
 - vent pipe size
 - quality control during construction

ii. User issues

- affordability of system
- education regarding use/abuse of system
- upgradability of system
- solids accumulation and removal
- sullage disposal (effect of small or large quantities of water in the pit)
- maintenance, cleaning materials and methods
- choice of materials
- pedestal or bench seat vs squat plate
- door vs no door
- door opening inwards vs outwards

iii. Environmental and health issues

- site investigations
- groundwater pollution
- plot size
- population density
- personal hygiene (washing hands, etc.)

3.2 Approach adopted

The approach adopted in the development of the guidelines has been to promote the proper construction of VIP toilets from two perspectives which differ in their design philosophies, viz

- VIP toilets with a permanent superstructure for permanent or long term use. These could be either a single-pit or double-pit type, both with access to the pit for cleaning purposes.
- VIP toilets with temporary superstructure for temporary or short term use, e.g. sanitation schemes for squatter settlements. These will normally be only of the single-pit type without access to the pit, as emptying would not be envisaged.

A VIP toilet may be designed in several ways. For example, it may be a single-pit unit or an alternating twin-pit system. The latter are always designed as a permanent, emptiable facility, whereas the former may or may not be designed to be so. Emptying may be done either manually or mechanically, the latter method using specially designed vacuum tankers. Additionally, pits may or may not need to be lined (to prevent structural collapse), and they may be partially raised above ground level (to minimize problems in rocky or high groundwater table areas).¹⁵¹

Thus there are four basic sets of design options:

- non-emptiable / emptiable
- non-alternating (single-pit) / alternating (double-pit)
- unlined / lined
- sunken / raised¹⁵¹

4. Personal hygiene

This report deals with the technical issues of VIP toilets, but health and hygiene aspects are also essential to the overall success of any sanitation project. This section emphasizes the need for using the toilet as part of personal hygiene. For more detail refer to "Actions Speak" ⁽²⁾ and "A handbook for village health educators", ⁽²¹⁾

Human faeces and urine are potentially dangerous because they may contain disease causing organisms. It is important therefore, to dispose of the faeces and urine in such a manner that the organisms are not spread to healthy people and thereby cause illnesses. To prevent the transmission of disease and contamination of the human environment and food with excreta, it is important to use toilets. ⁽²⁷⁾

Excreta attract flies, which can carry disease, and may also contaminate drinking and washing water, food, as well as cooking and eating utensils. ⁽⁴⁰⁾ Most pathogens are transmitted from the excreta to the mouth of another person. Some of them may reinfect by the inhalation of dust or aerosol droplets and there are also a few infections that can penetrate through the skin. ⁽⁷⁾ It is important that children use the toilet facilities and that hands are washed after using the toilet. ⁽⁴⁰⁾

An unacceptable method of excreta disposal leads to a lack of hygiene and to environmental pollution, while the proper use of toilets can be a major factor in the dramatic reduction of diseases such as diarrhoeal infections. ⁽²¹⁾

These excreta-related diseases are responsible for a large proportion of the morbidity and mortality in developing countries, where adequate water supplies and sanitation facilities are typically absent. Sanitation technologies used for the control of such diseases must be affordable to the communities. ⁽⁴⁸⁾

It is evident that three factors are necessary for community health: safe water, improved sanitation facilities and the correct disposal of refuse. It is moreover important that these three services coexist. ⁽¹¹⁾

5. Defects of ordinary pit toilets

Pit toilets suffer from undesirable defects. According to Rivett-Carnac ⁽²²⁾ the defects may include some or all of the following:

- the creation of breeding sites for flies and mosquitoes
- bad odour
- structural instability
- unsanitary conditions
- inadequate design for small children
- lack of privacy

Because of these problems, they are unpleasant to use and not a viable solution to the sanitation problem. ⁽²⁷⁾⁽¹¹⁾

The two main disadvantages of the unimproved pit toilet (without the ventilation pipe) are that it has a bad odour, and that substantial numbers of flies and other disease-carrying insects breed in them. ⁽¹⁴⁾⁽¹⁰⁾ Both these disadvantages are substantially reduced in VIP toilets. ⁽⁴⁾⁽³²⁾⁽¹¹⁾ However, the addition of a vent pipe is not necessarily the only factor which makes the toilet satisfactory.

The principles of the VIP toilet have been applied in countries such as Zimbabwe, Botswana, Ghana, Tanzania and Lesotho. It is clear that the VIP toilet (and the Ventilated Improved Double Pit toilet) is one of the most appropriate sanitation technologies for a wide variety of conditions in low income rural and urban communities in many developing countries.⁽³⁴⁾ Hence the ventilated improved pit toilet is now widely recognized as one of the most important, affordable and appropriate on-site sanitation technologies.⁽³⁵⁾

6. Operational principles of Ventilated Improved Pit (VIP) toilets

The VIP toilet has different components as shown in figure 6.1. The substructure, or pit, has a collar or lining to support the cover slab on which the superstructure is built. The cover slab is made with two holes, one for the pedestal or squat-hole and one for the vent pipe.⁽³²⁾ The superstructure can be fitted with or without a door and has ventilation openings. A vertical vent pipe is fitted on the vent pipe hole. This vent pipe, fitted with an insect screen, is the feature which distinguishes the VIP from ordinary pit toilets. This addition makes the toilet more hygienic and readily acceptable, but does add significantly to the cost or effort involved in construction, especially in the case of rural toilets.⁽³⁴⁾

When the wind blows, air moves through the vent holes, usually above the door, through the squat-hole or toilet seat, into the pit and out of the top of the vent pipe. The wind also blows across the top of the vent pipe and sucks foul air out of the pit. This air current minimizes odours inside the superstructure.⁽⁴⁰⁾⁽³³⁾⁽³⁷⁾

There are two explanations of the vent pipe's role in minimising odours, namely ventilation induced by wind and by solar radiation.

- Wind passing across the top of the vent pipe creates a negative (suction) pressure within the pipe so that air is drawn out and replaced by air from the pit, thus establishing ventilation.⁽²⁴⁾⁽³⁴⁾⁽²²⁾⁽¹⁰⁾⁽³⁷⁾⁽³³⁾⁽³⁶⁾
- The effect of solar radiation is to heat up the vent pipe and thus the air inside it. This air rises and is replaced with cooler air from the pit. In this manner odours emanating from the faecal material in the pit is drawn up the vent pipe, so leaving the superstructure odour free.⁽²⁴⁾⁽¹⁰⁾⁽³³⁾⁽³⁶⁾

In order to control insects a gauze covering is fitted to the top of the vent pipe. Flies are attracted to the top of the vent pipe by the odours emanating from it. Since the vent pipe is covered with a flyscreen, the flies are unable to enter and lay their eggs in the pit. Because flies are phototropic, those inside the pit will try to leave it via the vent pipe, provided that the superstructure is reasonably dark. They are prevented from leaving, however, by the flyscreen and in time they fall back into the pit and eventually die.⁽²⁴⁾⁽⁴¹⁾⁽³³⁾⁽³⁷⁾⁽²²⁾

The VIP is a dry toilet and urine as well as small amounts of water used for cleaning the cover slab and which is poured into the pit, infiltrates into the surrounding soil.⁽¹⁸⁾⁽³⁷⁾ Faecal solids in the excreta are digested anaerobically by bacterial activity in the pit.⁽¹⁸⁾

Fly control

Odour control

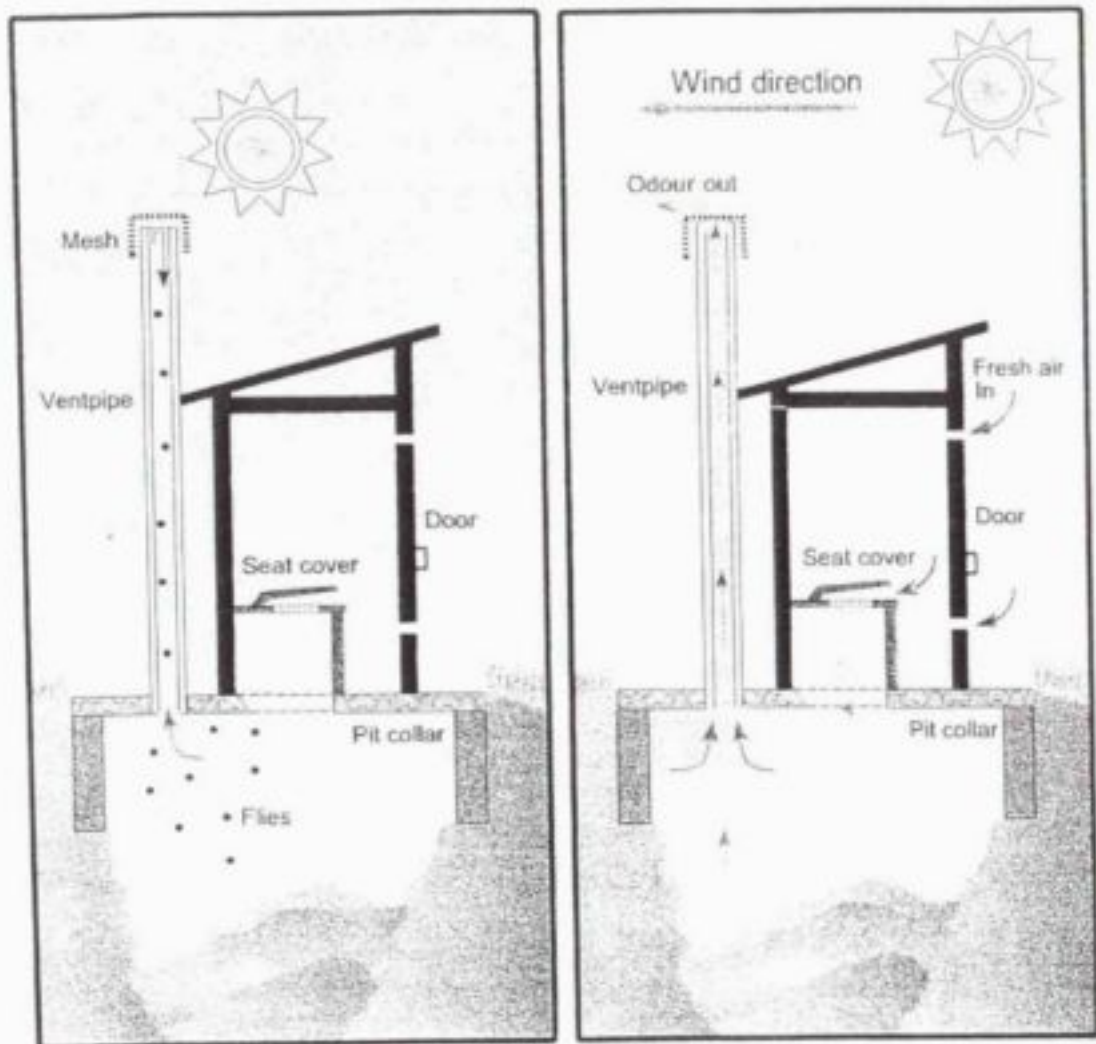

Figure 6.1: Operational principles of the VIP toilet.

Because they require no water for their operation (other than minimal amounts for cleansing) VIP toilets are a technically feasible sanitation option in areas where water use is low (less than 30 lcd) and where water has to be hand-carried from public standpipes or communal wells. ¹¹⁵¹

In terms of health and safety the VIP toilet compares very favourably with waterborne systems, but in terms of user comfort it is not competitive. Financial restrictions are the main reasons why a VIP toilet is the best alternative in certain circumstances. ¹¹⁰¹

The advantages of a VIP toilet can be summarised as follows:

- It is relatively cheap ¹²⁹¹
- Lowest annual cost of all sanitation systems ¹¹⁰¹
- Simple construction and maintenance ^{1101/291}
- No drainage outlet which can be clogged with foreign objects (maize cobs, stones, etc) ¹¹⁰¹
- Odourless and minimises the nuisance from flies and mosquitoes ¹¹⁰¹
- Hygienic ¹²⁹¹ with a small health risk ¹³⁰¹
- Requires very little water ¹³⁰¹
- Low level of municipal involvement ¹¹⁰¹
- Good potential for upgrading ¹¹⁰¹

Disadvantages are the following:

- Suitable only for rural and lower density urban areas ¹¹⁰¹
- Unsuitable for certain soil conditions ¹¹⁰¹ (problems may occur where the ground is rocky or where the groundwater table is close to the surface ²⁹¹)
- May pollute ground water to an unacceptable extent ¹¹⁰¹
- Temporary installation, except where the pit can be emptied ¹¹⁰¹
- Requires separate disposal of waste water ¹¹⁰¹
- Better than the bucket system from a health and cost point of view, but does not offer the same user comfort as waterborne systems ¹¹⁰¹
- It must be outside the home ²⁹¹

Although it is usually best to provide large deep pits for VIP toilets, this may not be possible where rock or groundwater lie within one or two metres of the ground surface. A variation of the VIP toilet suitable for such situations, the Ventilated Improved Double Pit (VIDP) toilet, has two shallow pits (between 1 metre and 1,5 metres deep ³²¹) side by side under a single superstructure. ¹⁹⁴¹

The VIDP toilet has the same operational principles as the VIP toilet, but differs from the VIP in that it has a double pit with a more permanent superstructure. ¹¹⁵¹ Each pit has its own hole or seat ¹⁰¹ and each pit should be provided with a vent pipe. ¹³²¹

The pits are used alternately ^{141/321} and only one pit must be available for use at any time ¹⁶¹. When the first pit is full, the user moves the pedestal to the second pit and caps the used one. ^{141/321} After a minimum period of one year it can be emptied either manually or mechanically and the contents disposed of on site, i.e. used as compost, or transported away. ^{1321/41}

The advantages of a VIDP toilet can be summarised as follows:

- Low annual cost ¹⁴¹
- Ease of construction and maintenance ¹⁴¹
- Absence of odour and minimal fly and mosquito nuisance ¹⁴¹
- Minimal health risk ¹⁴¹
- Permanent sanitation facility ^{141/101/101}
- Minimal water requirements ¹⁴¹
- Low level of municipal involvement ¹⁴¹

- Shallower pits can be used so that groundwater pollution is more easily avoided ⁽¹¹⁵⁾.
- It permits the restoration of the infiltrative capacity of the pit soil interface ⁽¹¹⁵⁾.
- Manual emptying is permissible ⁽¹¹⁵⁾.
- Greater flexibility in the precise time when the full pit is emptied ⁽¹¹⁵⁾.
- Potential for resource recovery ⁽¹⁴⁾ and production of an essentially pathogen-free product that can be handled without risk to public health ⁽¹³⁾.
- Good potential for upgrading ⁽⁴⁾.

Disadvantages are:

- Unsuitable for very high density urban areas ⁽⁴⁾.
- Unsuitable for certain soil conditions ⁽⁴⁾.
- May pollute groundwater ⁽⁴⁾.
- Requires separate arrangements for sillage disposal ⁽⁴⁾.
- Capital costs may be higher ⁽¹⁵⁾.
- User education may be required to gain acceptability ⁽¹⁵⁾.
- User education is necessary to ensure that both pits are not used simultaneously ⁽¹⁵⁾.
- More frequent emptying of the pits is necessary ⁽³²⁾.

Alternating twin-pit VIP toilets should be used where appropriate and cost-effective. They are not required if the toilet pits are not to be emptied. They are essential if the pits are emptied manually or if excreta reuse is to be practised. They are also essential if off-site treatment or hygienic disposal of the pit contents is impracticable. They are preferred where shallow pits are required and raised single pits are not feasible. ⁽¹⁵⁾ The VIDP system is suitable for higher population densities where relocation of the toilet is not feasible due to a lack of available space. ⁽³²⁾ In the case of a ventilated improved single pit toilet there should be at least two suitable positions per stand, which implies a lower residential density. ⁽¹⁰⁾

With the VIP system there is no need for fresh excreta to be handled by people, because the pit is usually covered when it is full. The initial cost of a VIP toilet is lower than for a VIDP toilet and no organization is needed to empty the pits. However, the problem of organization is eliminated if the users of the VIDP toilets are prepared to empty the pits themselves and use the contents as fertiliser. ⁽¹⁰⁾ A VIDP toilet is usually more expensive than a single-pit VIP toilet and requires a greater operational input from the user, particularly in changing over pits. ⁽⁹⁾ All projects involving the construction of double-pit toilets must allow for a prolonged support programme. ⁽⁹⁾ In some cases, however, VIDP toilets are not generally accepted by communities, and one needs to establish in advance whether they will be acceptable. ⁽⁴⁷⁾

7. Examples of different VIP toilets

Because of local preferences, varying conditions and availability of materials in different areas, different variations of the VIP toilet were developed. Hence some of the existing examples of VIP and VIDP toilets are summarised.

ROEC

The Reed Odourless Earth Closet (ROEC) of the 1940's was the precursor to the VIP toilet. ⁽³¹⁾ Figure 7.1 shows a ROEC pit latrine. ⁽⁷⁾

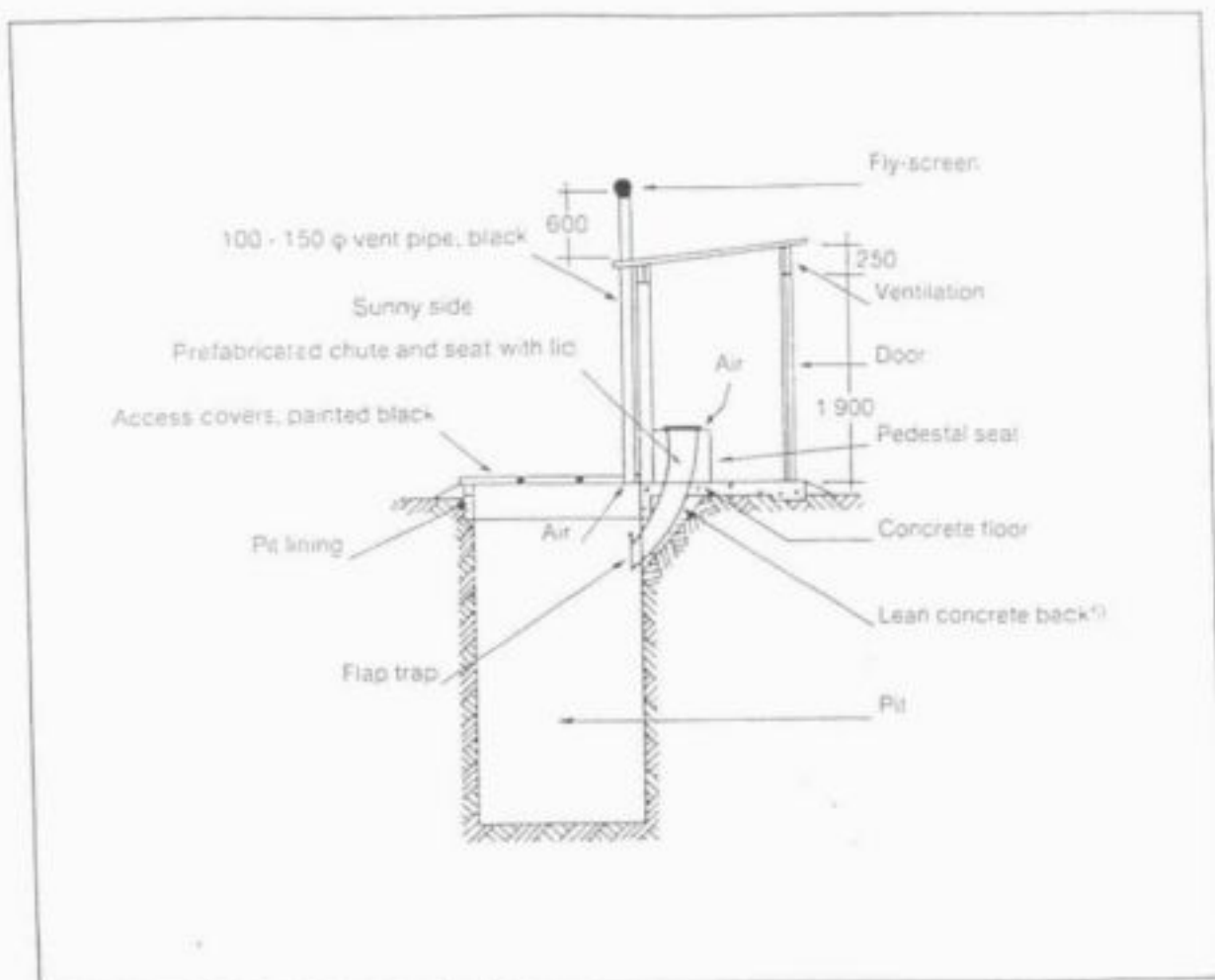

Figure 7.1: The Reed Odourless Earth Closet

BOTVIP ⁽³⁷⁾

The BOTVIP (figure 7.2) has been used successfully in Botswana. Four different designs for the BOTVIP are available. A rectangular (square spiral shape) superstructure is combined with a rectangular or circular substructure and a circular (round spiral shape) superstructure is combined with a rectangular or circular substructure. A schematic diagram of the BOTVIP is given in figure 7.3. ⁽³⁷⁾

An unlined rectangular substructure is used in stable soils, while a lined (masonry lining or wire-mesh lining) circular substructure is used in unstable soils. ⁽³⁷⁾

If a BOTVIP latrine is constructed in stable soil, a trench should first be excavated and a ringbeam cast in-situ. This beam is reinforced with 8 mm reinforcing bars and should be cured for three days. The circular pit for the masonry lining should be 1250 mm in diameter and 2 to 3 m deep. The lining is constructed by specially made trapezoidal blocks, with the bottom course and the top three courses mortared. ⁽³⁷⁾ For the circular substructure with wire-mesh lining a pit with a 950 mm diameter should be excavated to a depth of 2200 mm. After the lining is placed, the space between the excavation and the lining should be backfilled with gravel or sand. The top 500 mm should be backfilled with clay or a weak soil-cement mixture (10 soil: 1 cement). A 125 mm square ringbeam is cast around the periphery of the pit using the top of the wire-mesh, which is bent outwards, as reinforcement. ⁽³⁷⁾

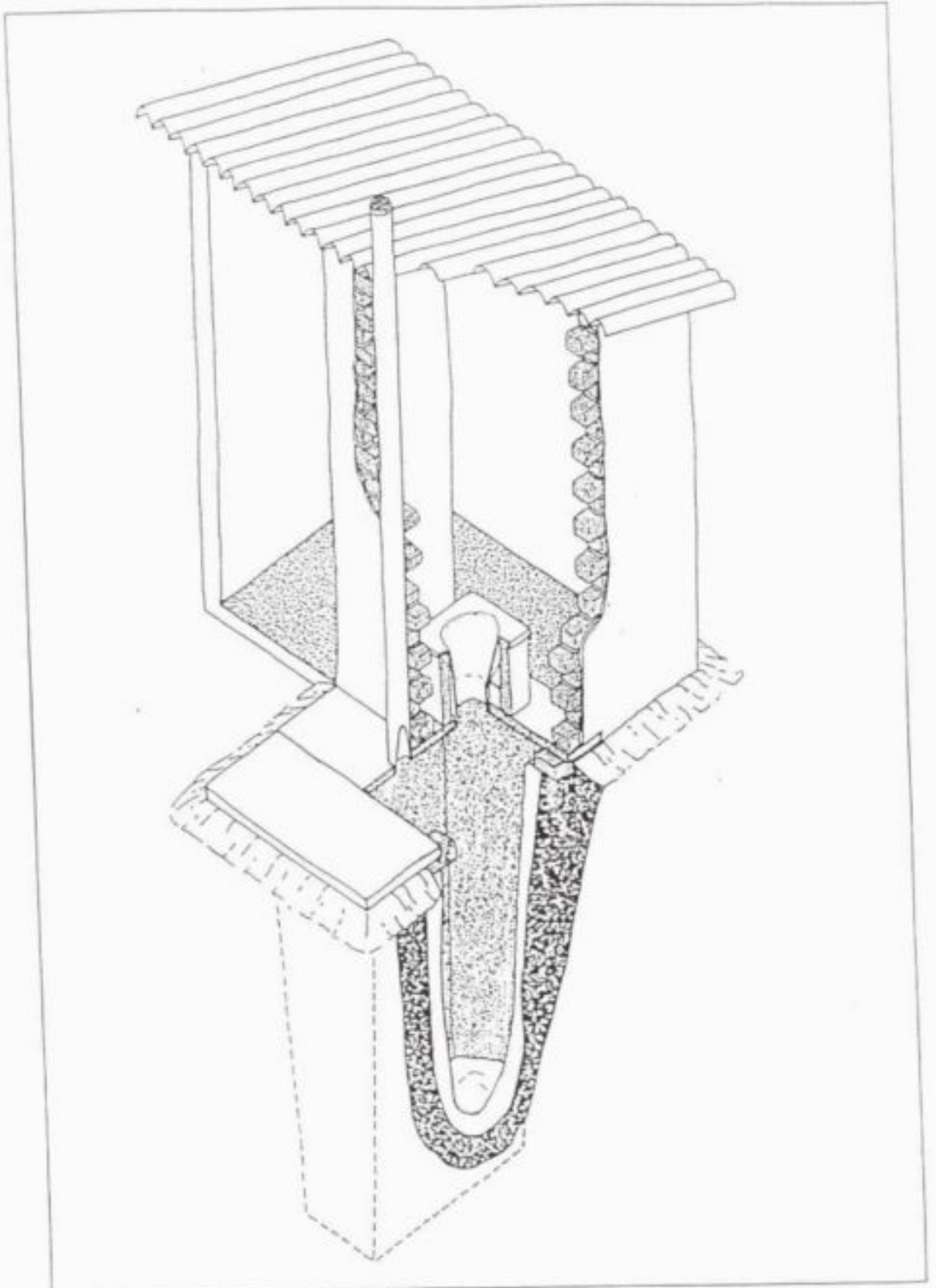

Figure 7.2: The BOTVIP

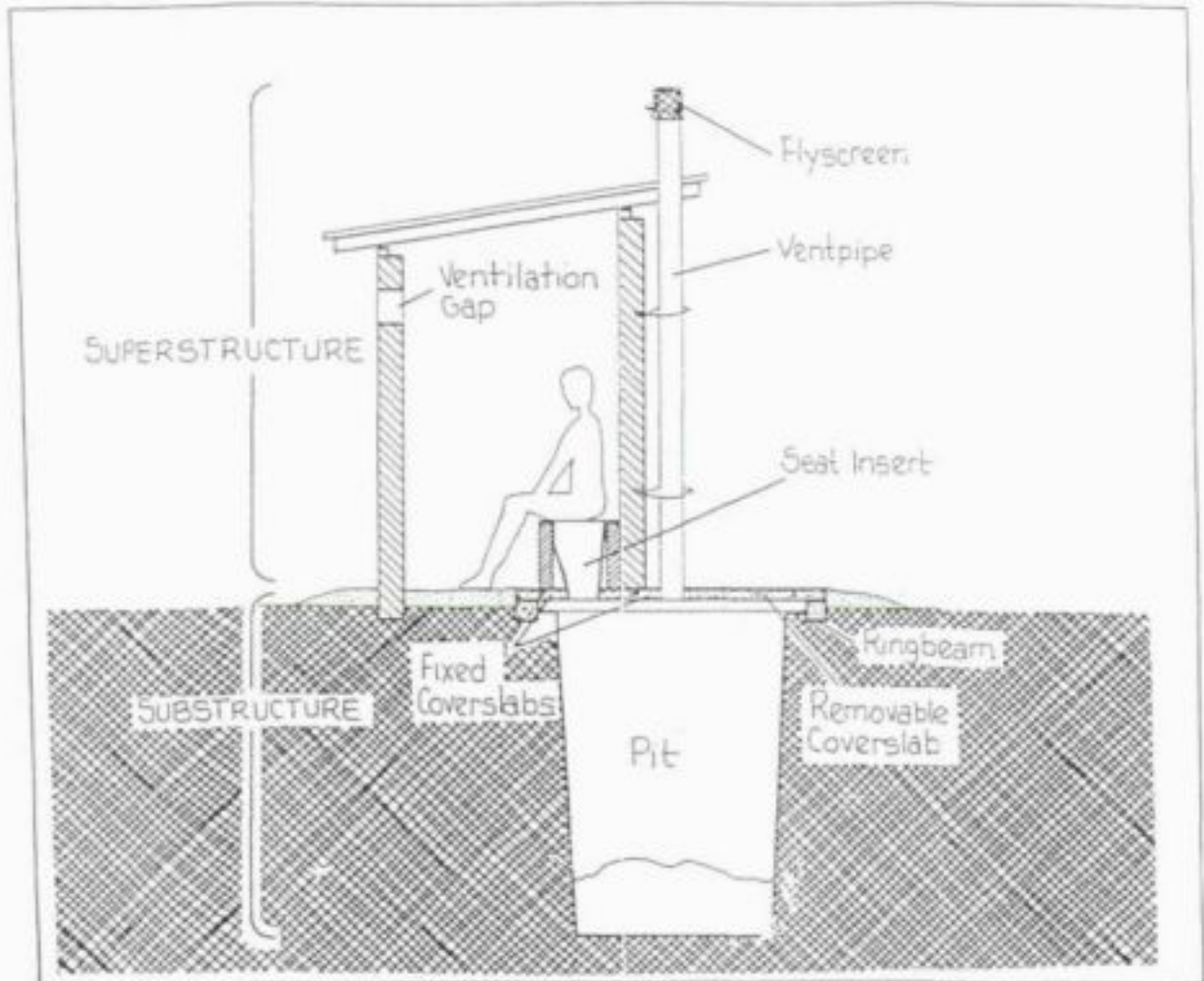

Figure 7.3: A schematic diagram of the BOTVIP

The circular pit can either be covered with a circular slab or two rectangular panels. Removable cover slabs on the pit enable the pit to be repaired, maintained and emptied. If the substructure is rectangular, three precast panels are mortared to the pit collar. ⁽²⁷⁾

A glass-fibre reinforced plastic seat insert or a seat made of wood or concrete is used in the BOTVIP latrine. ⁽²⁷⁾

The vent pipe of the BOTVIP latrine may be either polyvinyl chloride (PVC) or cement-wash hessian, with a plastic-coated glass-fibre or stainless-steel mesh flyscreen secured at the top of the vent pipe with galvanized wire or a pipe clamp. ⁽²⁷⁾

Zimbabwe design for rural areas

The rural VIP toilet (figures 7.4 and 7.5) has a rectangular pit (1,5 m x 0,6 m x 3 m deep). The cover slab is made out of logs (100 mm in diameter), which should be resistant to termite and fungal attack. This is covered with anthill soil and a thin layer of cement mortar. A spiral superstructure is then built in mud and wattle, thatch, soil or local bricks and covered with a conically shaped thatched roof. The vent pipe is made from local reeds, fitted with a flyscreen and rendered with cement mortar. ⁽²⁴⁾

Two types of vent pipe are also commercially available in Zimbabwe, one made of asbestos cement, the other of ultra violet stabilized PVC. ⁽²⁴⁾

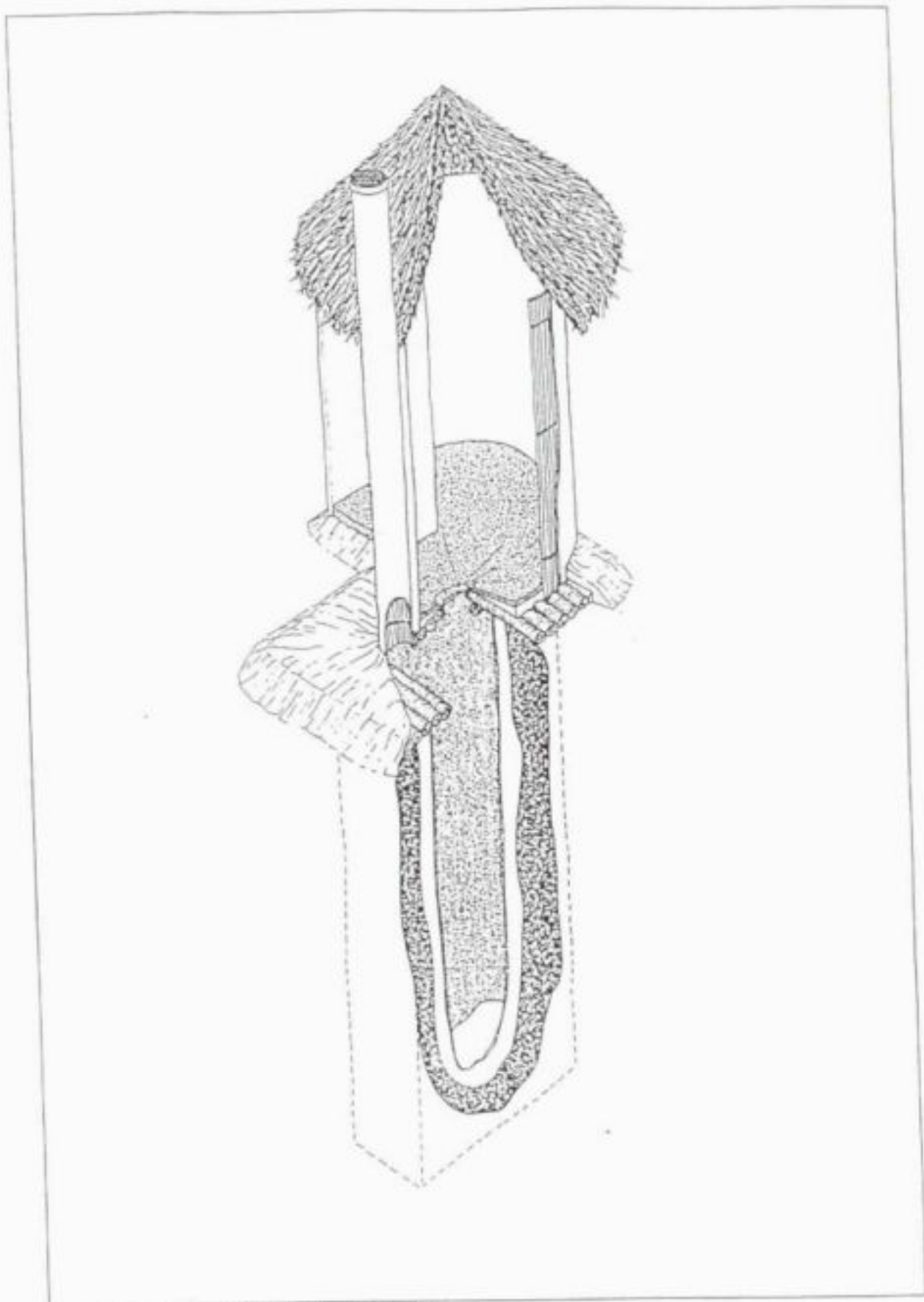

Figure 7.4: The rural VIP toilet in Zimbabwe

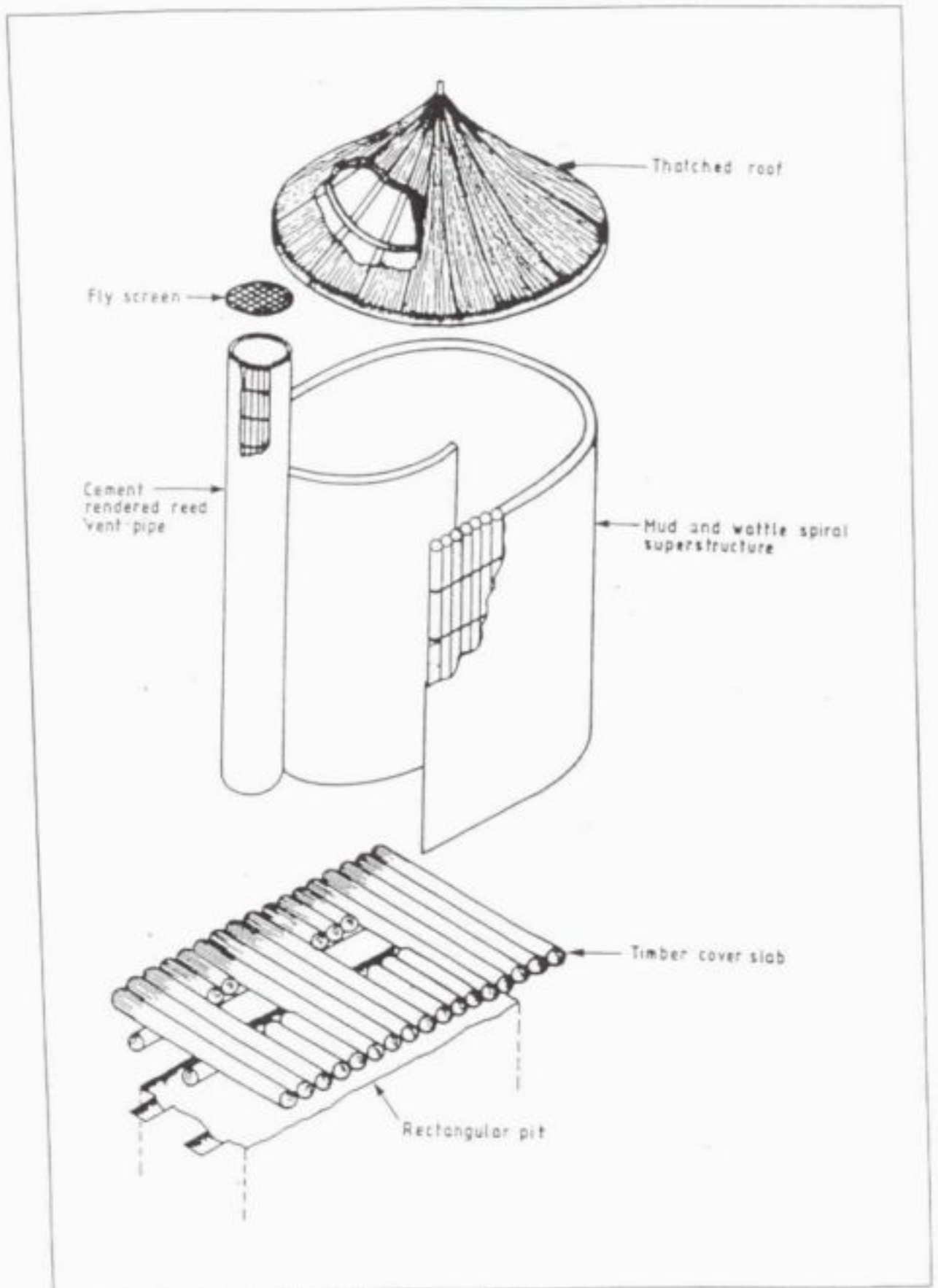

Figure 7.5: The rural VIP toilet in Zimbabwe (exploded)

Zimbabwe design for peri-urban areas ⁽²⁰⁾

The peri-urban VIP toilet consists of a circular pit (1,5 m diameter, 3 m deep) fully or partially lined with cement mortar. At the top of the pit is a brick collar to support the slab. A concrete slab is precast on site to cover the pit. It has a diameter of 1,9 m and is 75 mm thick. A grid of 6 mm mild



Figure 7.6: Photo of the ferrocement spiral VIP toilet in Zimbabwe

steel bars at 150 mm centres is used as reinforcement. ⁽²⁴⁾

The formwork for the spiral ferrocement superstructure is commercially available in Zimbabwe. It is made from 1,8 m wide corrugated galvanized iron sheeting and 40 mm steel angles, over which cement mortar is plastered. ⁽²⁴⁾

The roof is made of ferrocement. It is shaped in the same fashion as the superstructure, but 50 mm larger all round. The construction procedure is the same as for the cover slab, although the roof slab is thinner (25 mm) and reinforced with a single layer of chicken mesh. ⁽²⁴⁾

A 150 mm diameter asbestos cement or PVC vent pipe with a flyscreen at its top is erected immediately adjacent to the outside of the superstructure. Figure 7.6 shows a photo of the superstructure, while figure 7.7 is an exploded schematic diagram.

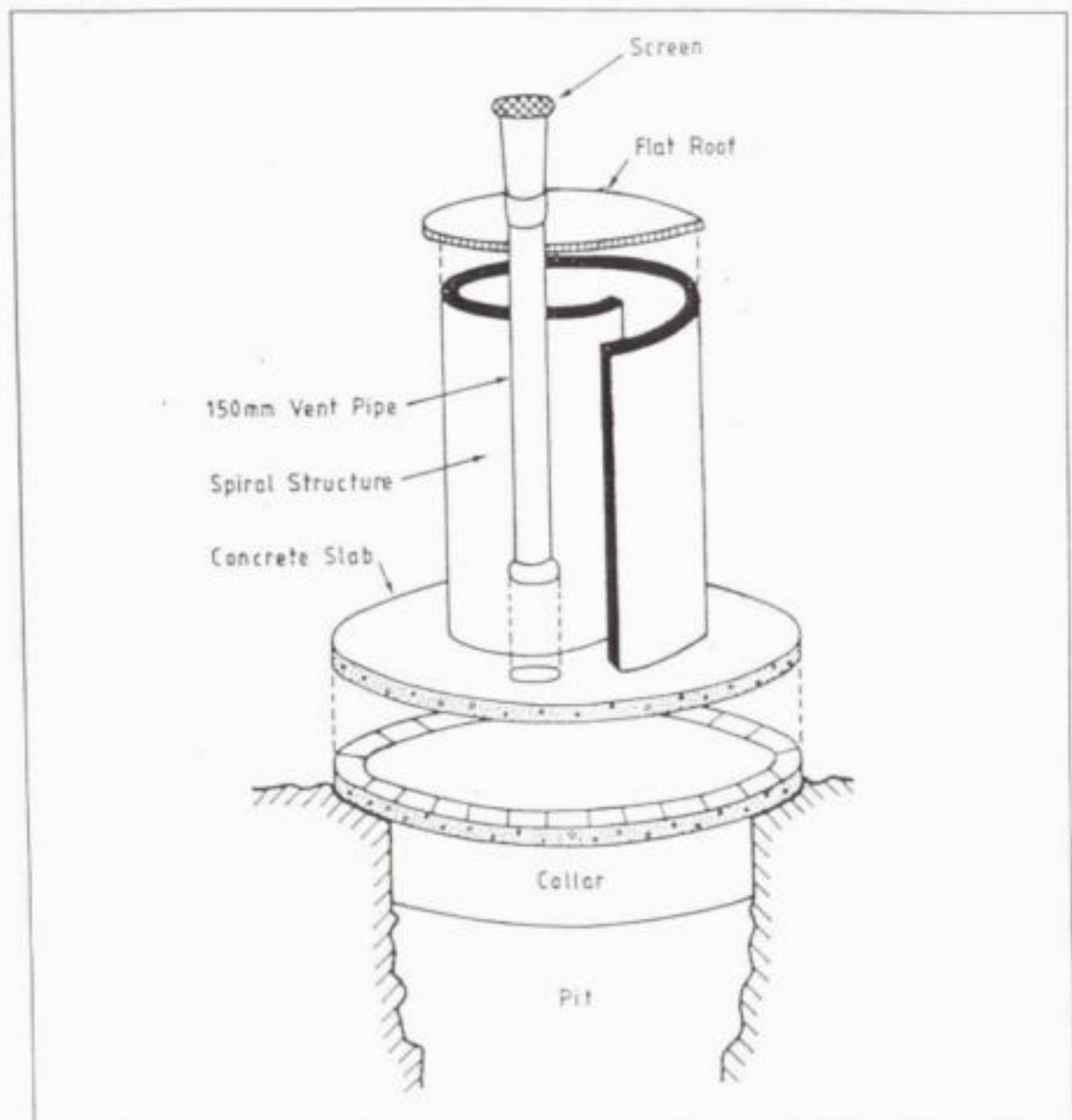

Figure 7.7: Exploded schematic diagram of the ferrocement spiral VIP toilet

Zimbabwe brick spiral toilet

This toilet is the same as the ferrocement spiral toilet, except that the superstructure is built of bricks (figure 7.8 and figure 7.9). Twenty courses of 20 bricks are laid in a spiral shape. The interior and exterior may be rendered with cement mortar, if required. In conjunction with a brick superstructure a brick vent pipe may be used. This vent pipe is a chimney-like structure with inside dimensions of 225 mm x 225 mm. Brick vent pipes have the advantage of retaining heat longer than either PVC or asbestos cement pipes and can thus maintain a thermally induced circulation of air well into the night.^[24]

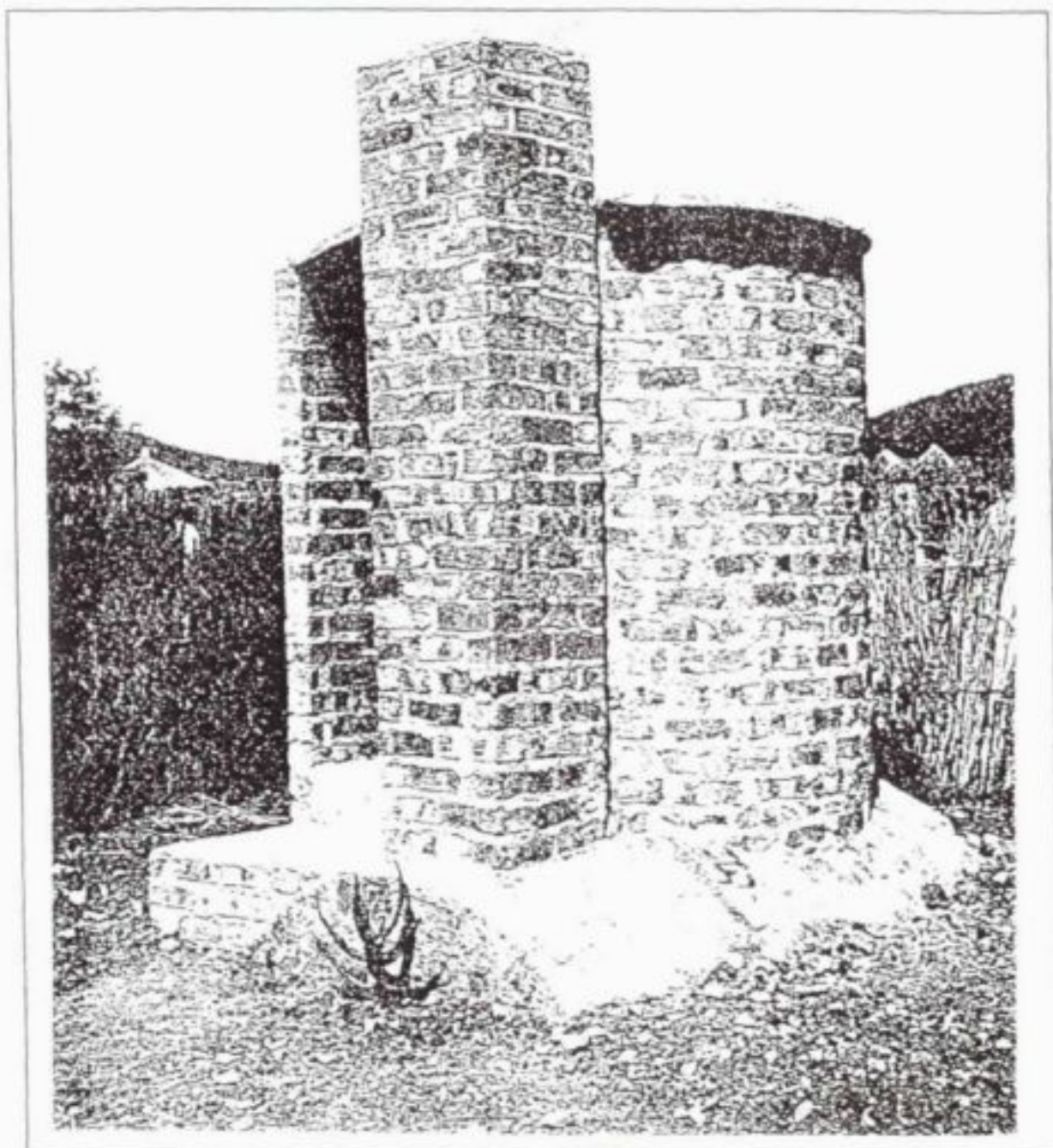

Figure 7.8: Photo of the brick spiral VIP toilet in Zimbabwe

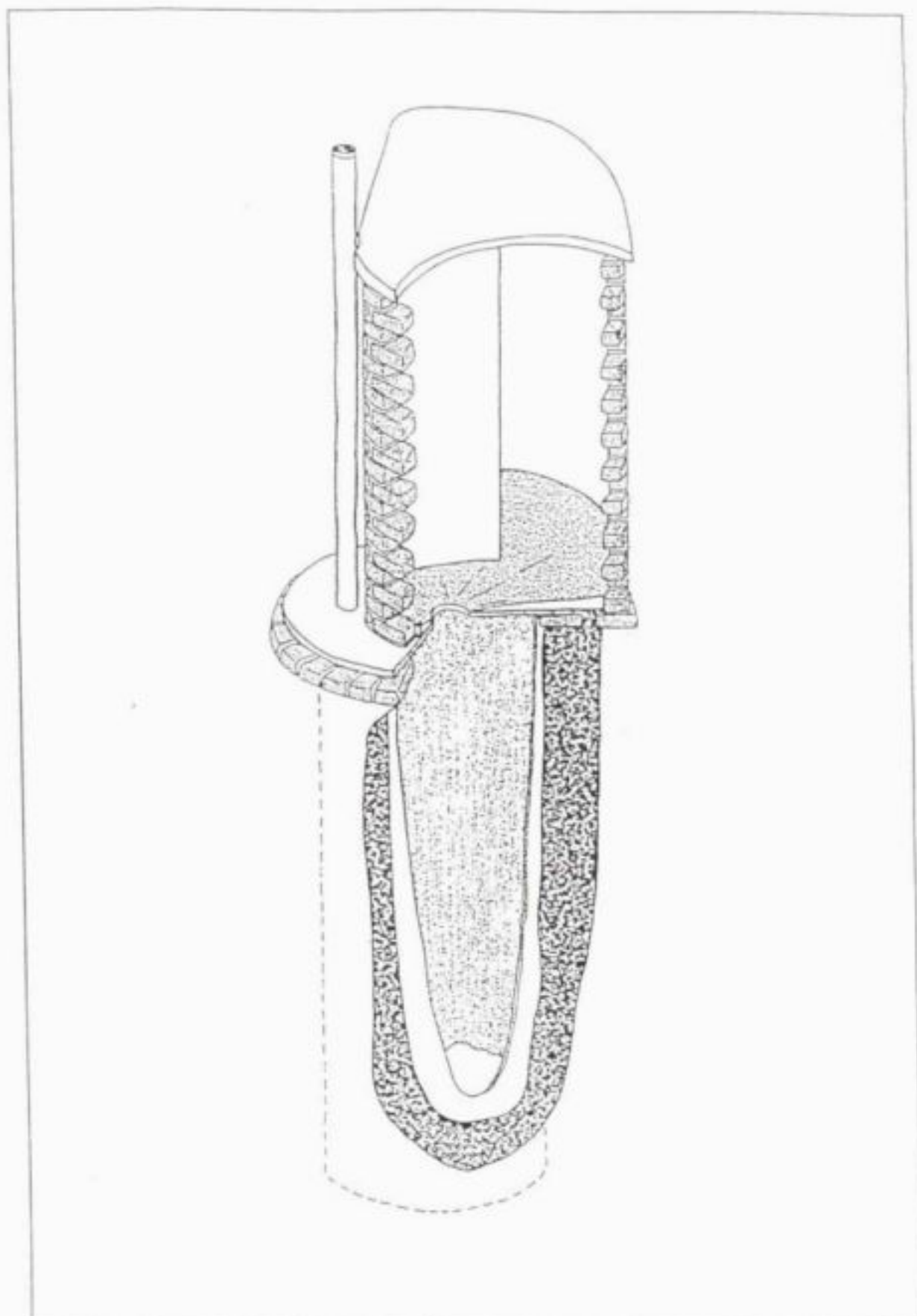

Figure 7.9 : The brick spiral VIP toilet in Zimbabwe

Blair VIP Latrines

Blair latrines in Zimbabwe are built of brick and cement mortar and the pits are sized to last for a period of 10 to 12 years. The standard Blair model consumes about five bags of cement. Other models derived from this model use between one and four bags of cement. A double compartment and multi-compartment Blair latrine have also been designed and used extensively throughout Zimbabwe. ⁽²²⁾

One bag of cement is needed to built a one bag Blair model, two bags of cement for the two bag model, etc.

For the one bag model (figure 7.10) a 2 m deep pit, with a diameter of 1,2 m, is dug. The pit is unlined with a grouted stone or brick ringbeam (1,65 m outside diameter). The cover slab has a diameter of 1,5 m. The vent pipe can be either a round mortar pipe, made by using a grass mould, or a bamboo/reed pipe covered with cement/plastic (± 110 mm inside diameter). The superstructure is a round spiral built from wooden poles covered with reeds or grass, or poles and dagha. It has a thatch roof and the floor consists of bricks or rammed termite soil and stones. ⁽¹⁸⁾

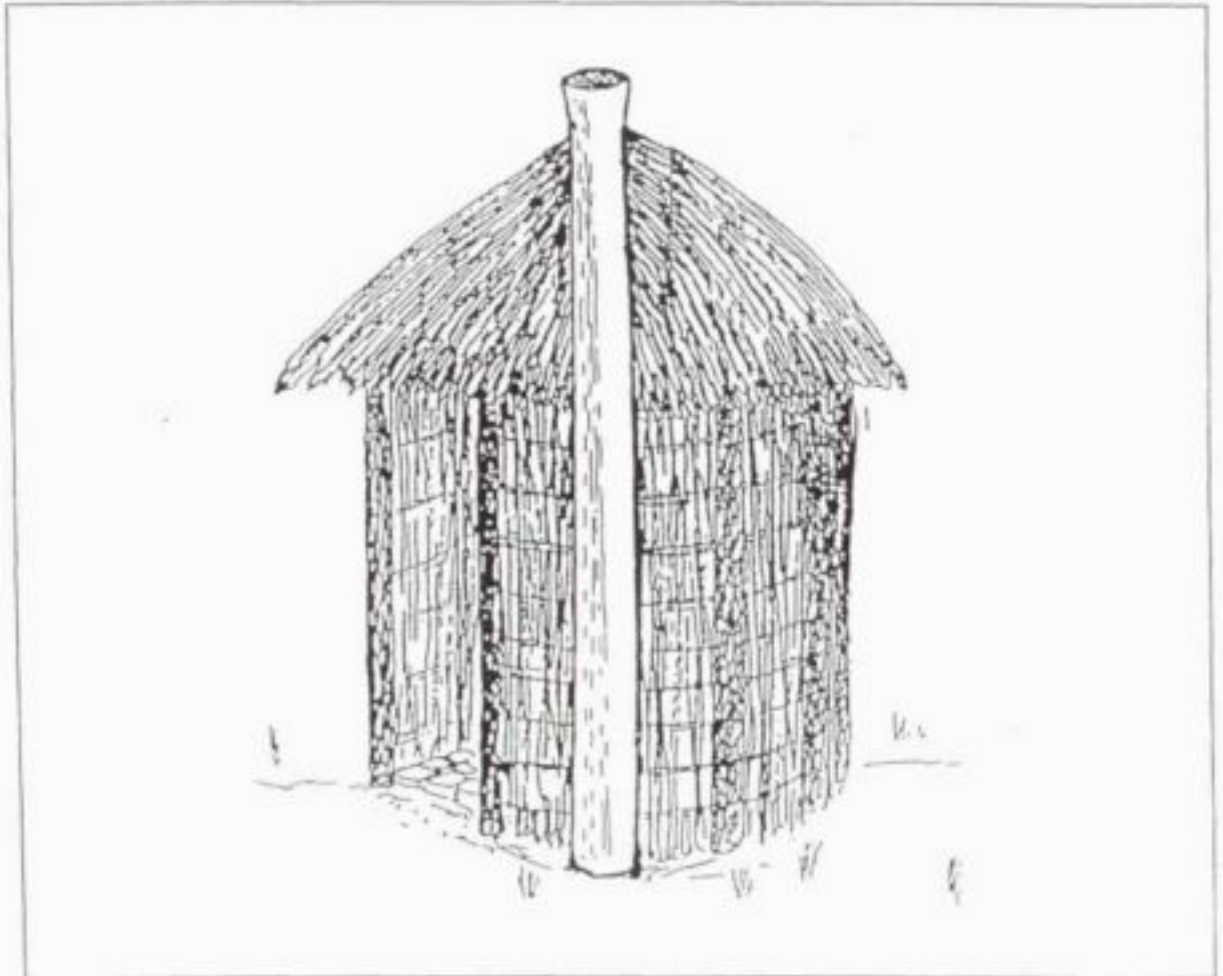

Figure 7.10: The Blair latrine (One bag model)

The pit of the two bag model is dug to a depth of 2 m and a diameter of 1,3 m. It is brick lined with an inside diameter of 1,1 m. The lining is extended to one course above ground level. The slab has a diameter of 1,3 m. The vent pipe is constructed with mortar and four bricks per course and should have internal dimensions of 140 mm x 140 mm. The superstructure has a square spiral shape and is built with bricks or blocks bonded with anthill mortar. The inside is also plastered with anthill mortar. A thatch roof is used and mortar with a cement skimming is used for the floor. ⁽¹⁹⁾

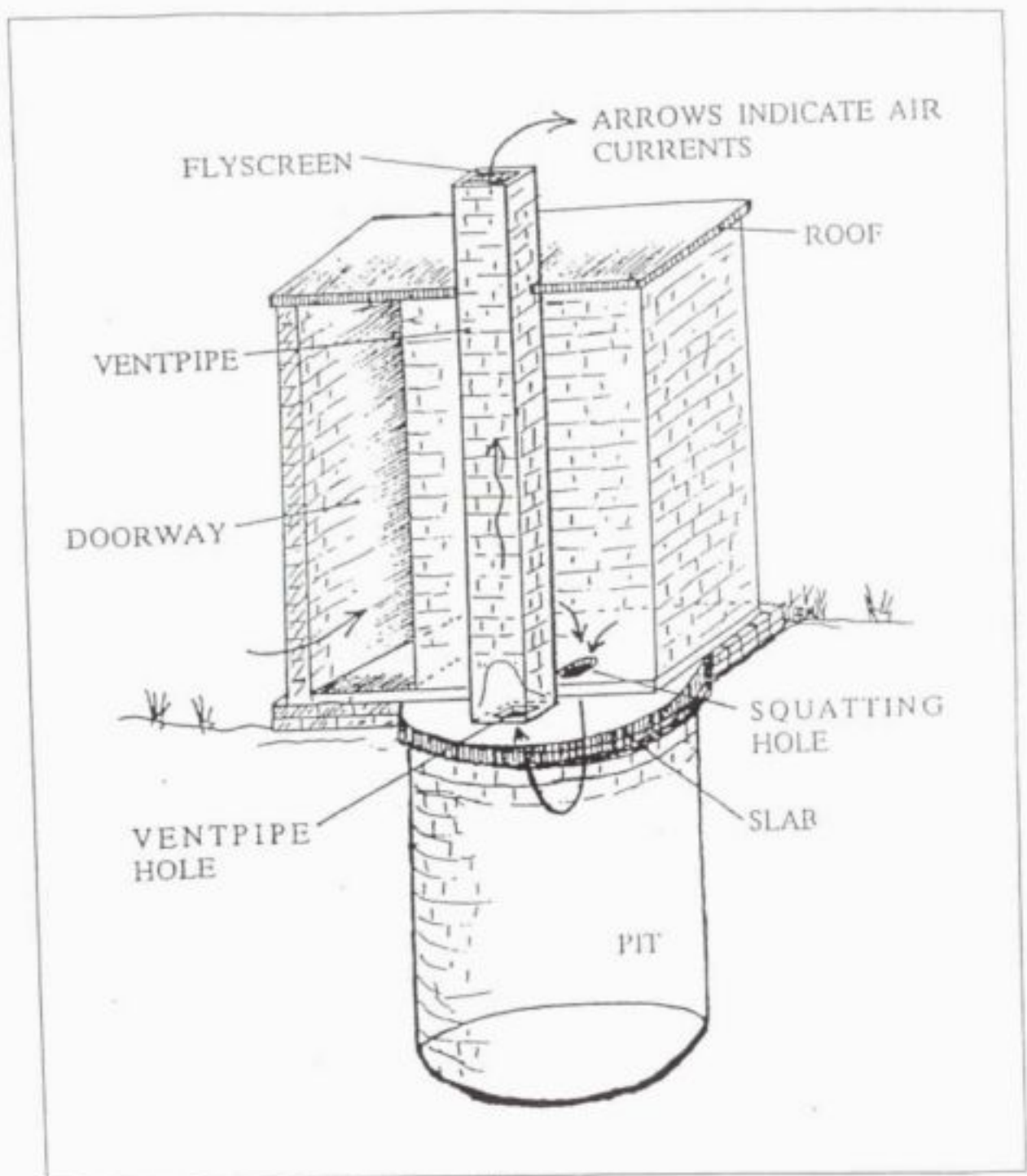

Figure 7.11: The Blair latrine (Standard model)

The three bag model has the same slab, floor and vent pipe as the two bag model. The pit is 2,9 m deep, 1,3 m in diameter and brick lined, with an inside diameter of 1,1 m. The superstructure has a square spiral shape and is built with bricks bonded with anthill mortar. The walls are 1,8 m high and plastered internally with cement mortar. A corrugated zinc or asbestos roof supported by wooden beams is used, but a thatch roof can also be constructed. ⁽²⁰⁾

The pit, slab, floor, vent pipe and superstructure for the four bag model are the same as for the three bag model. The roof, however, is made of ferrocement with chicken-wire reinforcing. ⁽²¹⁾

The five bag model (standard model shown in figure 7.11) has a pit of 2,9 m deep and 1,5 m in diameter. The brick lining in the pit has an inside diameter of 1,3 m. The slab has a diameter of 1,5 m. The internal dimensions of the vent pipe are 225 mm x 225 mm and is built with mortar and six bricks per course. The superstructure, roof and floor are the same as for the four bag model.¹²⁰

The one bag model is the only unlined pit version. This model has the smallest pit and the five bag model the largest pit. All the slabs are 75 mm thick and reinforced with 3 mm steel wire, spaced at 150 mm in a grid. All the flyscreens for the different Blair models are stainless steel or aluminium mesh. The superstructure of the one bag model is a round spiral shape, but all other models are square spirals with identical interior dimensions. None of the models have doors.

Lesotho Standardized VIP Latrine

In Lesotho, the VIP concept was adapted from work carried out in Botswana and Zimbabwe. The designs required modification for the particular conditions in Lesotho. For example, consumer preferences dictated that squatting slabs in VIP toilets were totally unacceptable, and a seat had to be incorporated into the design.¹²¹

The spiral Zimbabwe design (without a door) was not acceptable, partly because people in Lesotho are often frightened that snakes or other small animals might lurk in the toilet. A bench seat was preferred, as an animal would not be able to hide behind it. The preferred construction material for most people in urban areas was concrete blocks.¹²¹

Four different designs, each with different sized slabs, were originally promoted in Lesotho. This led to increasing confusion and the need for a standardized national design. The national design does not restrict the type of materials that are used for the superstructure. These can be altered according to taste, local availability of materials, financing, etc. The National VIP in Lesotho can be built as a ringbeam VIP or with a fully lined pit.¹²¹

In Lesotho the fully lined VIP pit has a top area of 0,9 m x 2,2 m and a depth of 1,85 m. The slab used in the national VIP and VIDP designs for Lesotho should cover at least 1 m span. The use of crushed stones should be avoided and a simple formwork (one size of form for all the slabs) should be used. The agreed slab size is 1,2 m x 0,85 m, and the thickness should be 50 mm. Eight reinforcing bars of 6 mm diameter should be used over the 1,2 m length, whereas six are needed over the 0,85 m span.¹²¹

Wits VIP latrine

The University of the Witwatersrand (Rural Facility) proposed two standard designs for VIP toilets. The one design consists of a circular pit, a blockwork superstructure, galvanised corrugated iron roof and a lockable door. The other design has a spiral shape without a door and is simply a modification of the standard design. The same materials are used for the superstructure.¹²²

SanPlat¹²³

The SanPlat (figure 7.12) concept originated from earlier toilet designs where the pit was basically sealed except when in use. Although it is not a VIP toilet, it is also not an ordinary pit toilet. The system comprises a pit with a slab and a superstructure as in any other toilet; the main variation, however, is in the slab itself, which is dome-shaped and does not allow ventilation of the pit, but rather isolates it.¹²³

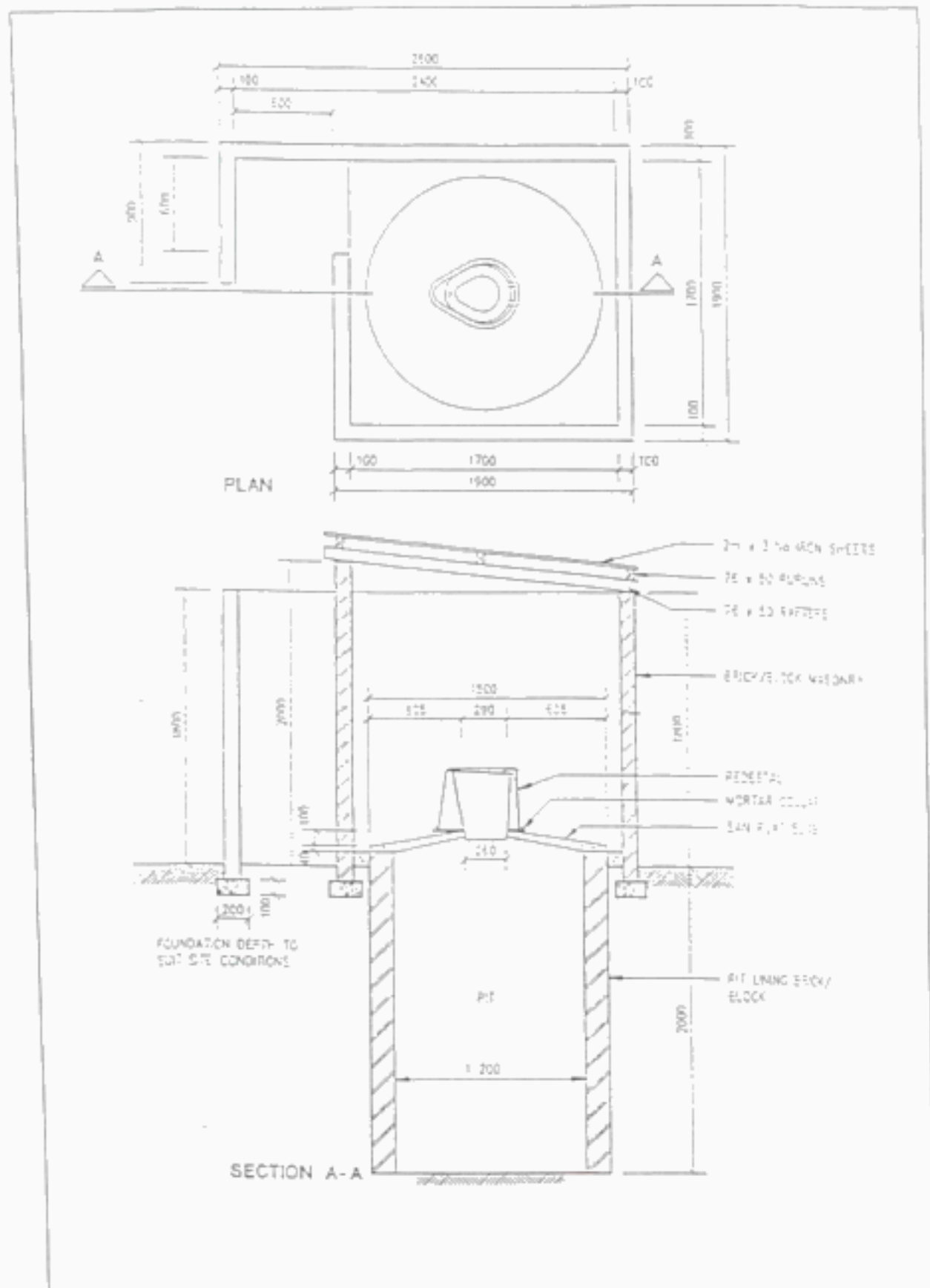

Figure 7 12: The SanPlat latrine

Urban VIP toilet in Tanzania ⁽¹⁶⁾

The single-pit VIP toilet shown in figure 7.13 has been constructed in several low income areas in Tanzania. It contains several novel features. The pit (1,3 m x 1,3 m x 2,5 m) is lined in special blockwork. Each block has two rectangular openings in it for pit drainage. The superstructure is not offset from the pit but, to allow access for desludging, the central part of the cover slab, which contains the squat-hole, is removable. The vent pipe is built up internally in one corner of the superstructure. The roof is made from fibre-reinforced cement sheets and the vent pipe passes through it and projects 400 mm above it. PVC-coated glass-fibre or stainless steel flyscreens are used. ⁽¹⁶⁾

Urban VIP toilet in Brazil

The VIP toilet developed in Brazil is shown in figure 7.14. The pit dimensions are 1,5 m x 1,1 m x 2,5 m deep, and the pit is lined in open-joint brickwork. The cover slab is in three sections, of which two are removable to permit access for desludging. The superstructure, which is offset from the pit, is large enough (1,6 m x 0,8 m internal) to permit "bucket showers" to be taken. The resulting sullage is drained to a small adjacent soakaway. ⁽¹⁶⁾

NBRI VIP latrine

The NBRI VIP toilet has a circular substructure which is lined with self-supporting bricks and a rectangular superstructure built with concrete blocks. Removable precast slabs or self-supporting bricks can be used to cover the pit. Floor slabs are often unsafe because of poor quality control and curing. By using self-supporting bricks the need for steel is eliminated and very little skill or supervision is required. ⁽¹⁷⁾

REC II (VIDP latrine in Botswana) ⁽²⁶⁾

The Revised Earth Closet Type II (figure 7.15) latrine in Botswana is particularly suitable for use in urban areas. It was derived from the traditional pit toilet for the more complex urban conditions. The pit of the old toilet was covered permanently when it became full and the toilet was relocated. Because plots in urban areas are small, however, a more permanent superstructure was preferred. The REC II provides two shallower pits side by side, straddled by a single superstructure. If one pit is full, the glass-fibre reinforced plastic pedestal is moved to the other pit and the full pit is sealed. ⁽²⁶⁾

In stable soil conditions a 250 mm square ringbeam is cast in a trench around the perimeter of the pits. After excavation, only a single strip foundation to support the dividing wall of the REC II (VIDP) latrine is poured in this case. ⁽²⁶⁾

In unstable soils a perimeter trench should be dug at the bottom of the excavation and a concrete strip foundation cast for the perimeter wall. The top of this foundation should be no less than 1250 mm below the natural ground level. The lining for the perimeter wall consists of 150 mm solid blocks, with the top two layers fully sealed. All joints in the central dividing wall should be well sealed, however. ⁽²⁶⁾

The pits of the REC II VIDP latrine are covered with eight precast cover slabs. ⁽²⁶⁾

If a pit becomes full the portable pedestal, which is designed for all age groups, is moved to the adjacent pit and the full pit is sealed. Both pits are ventilated by separate black PVC vent pipes. ⁽²⁶⁾

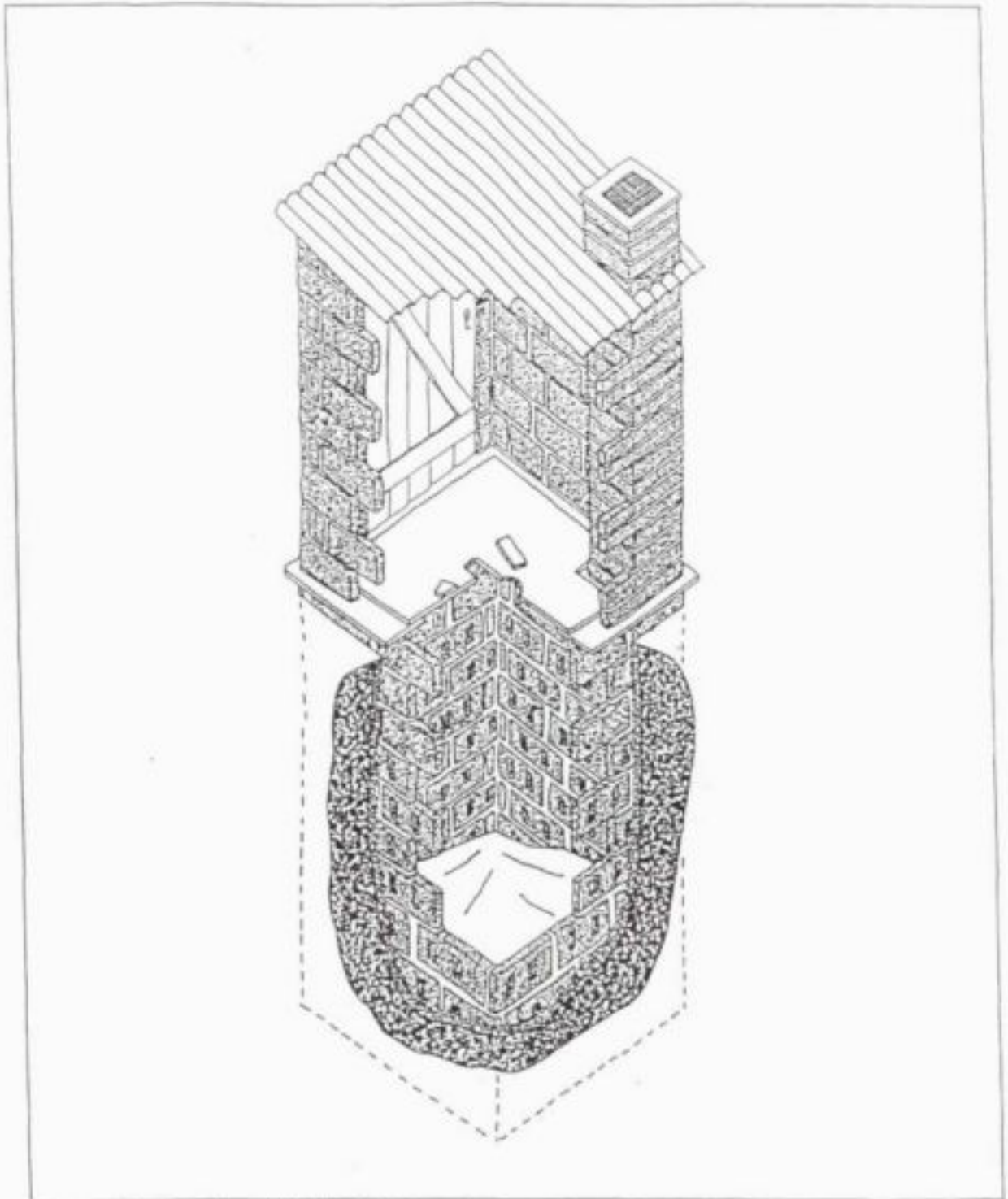

Figure 7.13: The urban VIP toilet in Tanzania

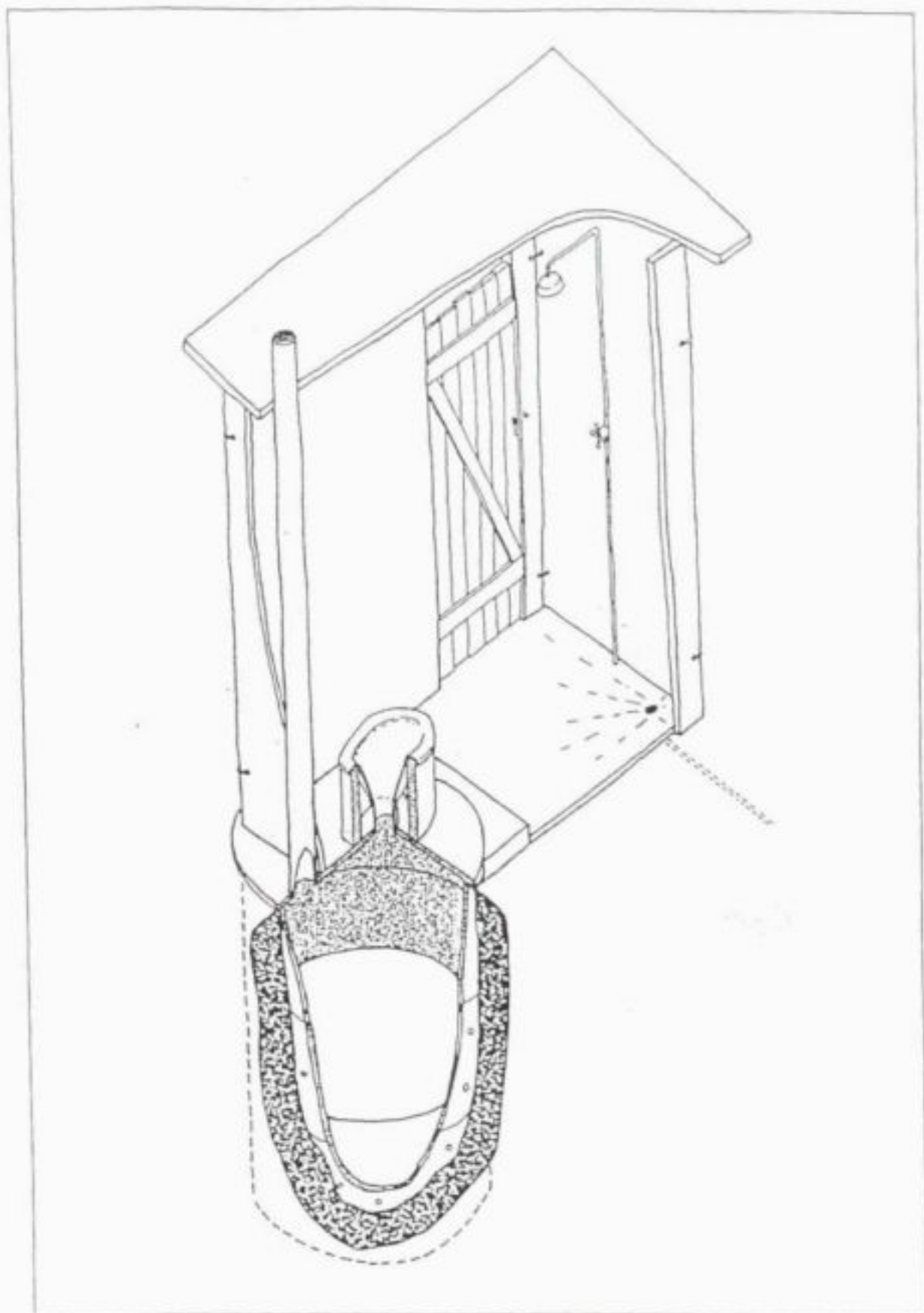

Figure 7.14: The urban VIP toilet in Brazil

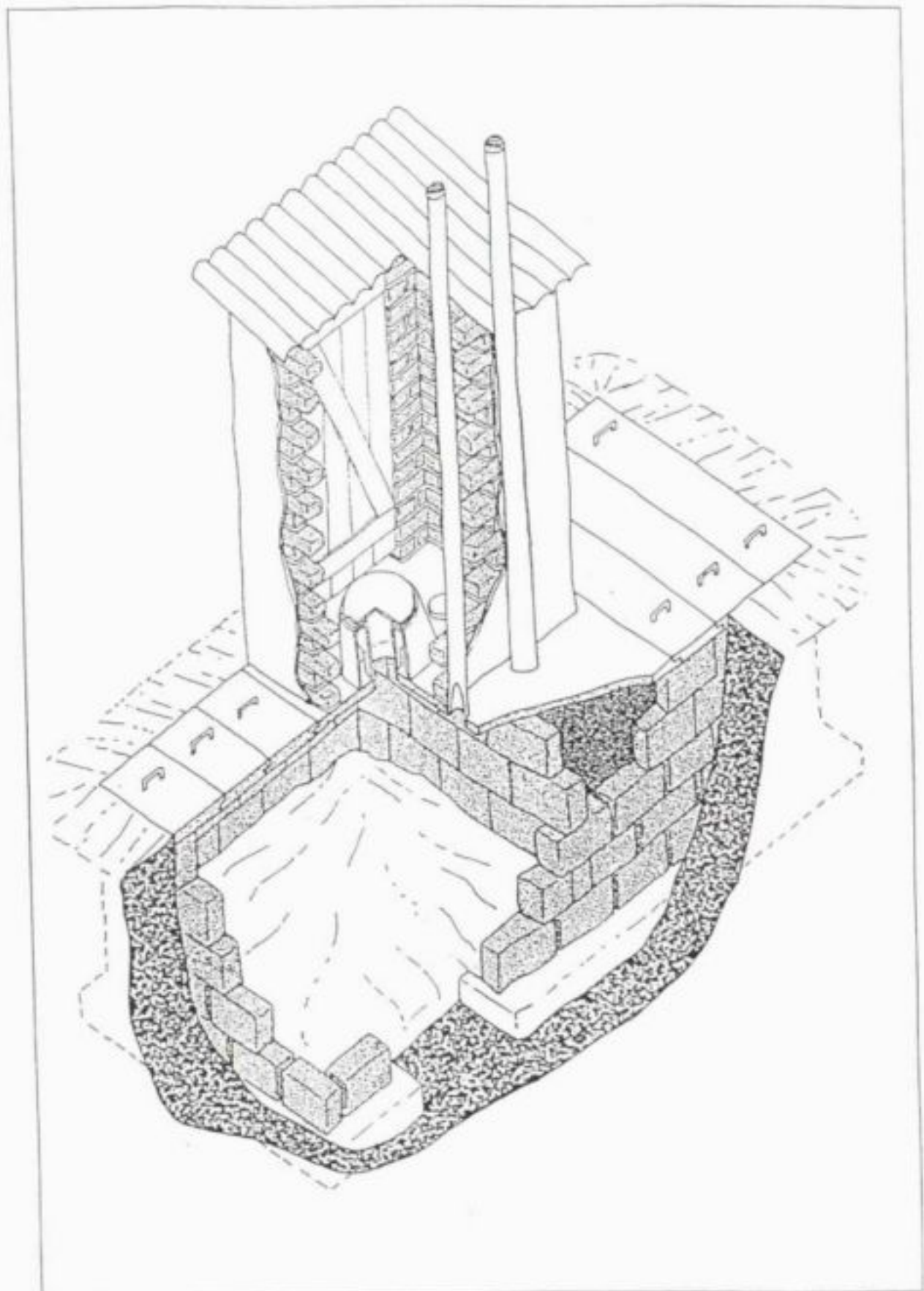

Figure 7.15: The REC II VIDP latrine

Double Compartment Blair latrine

The double compartment Blair latrine is built mostly at schools and clinics and sometimes also at family households. Two adjacent superstructures with square spiral shapes are built on twin pits. ⁽²²⁾

National VIDP Toilet Design in Lesotho

Although VIDP toilets seemed a perfect, permanent sanitation solution for small urban plots, they were not actively encouraged after 1987 because people refused to empty the pits manually, irrespective of what the contents looked and smelled like. Also, they would never use the decomposed contents in their vegetable gardens. About 10 to 20 percent of all rural toilets in Lesotho are VIDP. ⁽²³⁾

Nepal VIDP Latrine

In refugee camps in Nepal ventilated improved double-pit toilets, each used by two neighbouring families, were built. The tasks involved in building the toilets were classed as 'skilled' and 'unskilled'. The refugee family performed all the unskilled tasks with supervision and advice, while construction teams did the skilled tasks such as setting ring moulds and hand-forming the squat plate. ⁽²⁴⁾

The substructure of the Nepal VIDP latrine provides two pits, each with a volume of about 1 m³. The average fill-time of the pits is more than 500 days. The pits are partially lined with 1,2 m wide concrete rings to add support to the pit sides. The wall thickness of the rings is 40 mm. ⁽²⁵⁾

Concrete lids are used to cover the substructure. The lids have joints and lifting rings cast into them so that they can be removed and the pits cleaned out when necessary. ⁽²⁶⁾

The door and walls of the superstructure are made of bamboo poles with wattle and mud daub. The bamboo is available locally. The toilets have a sandwich-panel roof, made of layers of flattened bamboo and plastic sheeting to provide rainproofing. ⁽²⁷⁾

NBRI VIDP latrine ⁽⁴⁾

The pits of the NBRI VIDP latrine have a depth of between 1 and 1,5 m. Vertical joints in the lining should be left open, except for the top 200 mm to 300 mm. However, the joints in the dividing wall should be well sealed. The lining should extend to at least 75 mm above ground level. Earth at the bottom of the pit should be loosened to improve drainage. The pits are covered with removable slabs.

The superstructure is built of concrete blocks and a standard steel door is fitted. A precast pedestal with seat and cover is recommended.

Although a single 150 mm vent pipe can be used to ventilate both pits of the toilet, each pit should preferably have its own vent pipe with fly screen. The vent pipe should be corrosion resistant. ⁽⁴⁾

8. Substructure

8.1 General

The substructure, or pit, of the VIP toilet can be circular or rectangular. Circular pits are more stable than rectangular (or square) ones ⁽¹²⁾⁽²⁶⁾ and because it lends itself to greater stability a circular pit is recommended wherever possible. ⁽⁸⁾⁽²⁶⁾

A distinction is drawn between wet and dry pits. Dry pits are dug in permeable soil and any water in the pit soaks away easily, whereas wet pits are usually dug in less permeable soil so that any water added to the pit is retained for a longer period. Decomposition takes place more rapidly in wet pits than in dry ones. ⁽³⁰⁾ Hence wet pits have the advantage that they last longer than dry pits, as their rate of solids accumulation is lower. However, wet pits can pose problems such as mosquito breeding and groundwater pollution. ⁽¹⁶⁾

Depending on the soil conditions, the pit may be lined or unlined. If it is dug in stable soils the pit need not be lined, whereas lining is necessary in unstable soil conditions. Stable and unstable soils are described in the Design and Construction Guidelines for domestic VIP toilets.

If the soil is rocky or the water table is within 1 m of the surface, the pit can be built partly above ground level. In such cases the cost advantage of the VIP toilet may be eliminated. ⁽¹⁰⁾

Although it is usually best to provide large deep pits, this may not be possible where rock or groundwater lie within one or two metres of the ground surface. ⁽⁹⁾ Where there is a solid rock profile base within 1 m to 1,5 m of the surface, a different shape (rectangular as opposed to circular), or an alternative type of toilet, should be considered. ⁽⁶⁾ The VIDP toilet has two shallow pits side by side under a single superstructure and is suitable for such conditions. ⁽⁸⁾

8.2 Location

The substructure should not be closer than 2,75 m from the boundaries of the plot. This leaves space for access by maintenance crews. ⁽²⁰⁾

The pit should be at least 30 m away, and downhill from, a borehole or well. ⁽³²⁾⁽⁴²⁾ It should be on slightly raised ground with firm soil. It should also be near the house and away from trees. ⁽³²⁾

While choice of position is limited in crowded areas, every effort should be made to avoid water courses, earth banks and other positions which enable disease bearing effluent to flow into areas of human contact. ⁽²⁵⁾

Old river terraces generally have few, if any, binding materials in the soil, therefore making it unstable and dangerous to excavate. VIP toilets in such locations should therefore be avoided. ⁽⁶⁾

8.3 Pit capacity

The pit should have sufficient volume to provide for several years of continuous use, without the need for emptying or relocating. ⁽³²⁾

The required pit volume depends on the solids accumulation rate, the number of users and the desired life of the pit. A free space at the top of the pit, usually 0,5 m, must be allowed for in the design. The effective pit volume, which is the total volume less the free space volume, is calculated as follows:

$$\text{Solids accumulation rate} \times \text{Number of users} \times \text{Design life (in years)}$$

In dry pits the solids accumulation rate varies between 0,03 and 0,06 m³ per person per year, and in wet pits between 0,02 and 0,04 m³ per person per year. Accumulation is lower in wet pits because biodegradation is faster under wet conditions than under the just moist conditions in dry pits. These design values should be increased by 50% if bulky anal cleansing materials (for example, corn cobs, cement bags, etc.) are used, as these degrade only very slowly. For the design life, ten years should be considered desirable. ⁽¹⁶⁾

According to Rivett-Carnac ⁽²²⁾ the formula for designing the required effective volume (V_e) of the pit is:

$$V_e = C.P.N \text{ (m}^3\text{)}$$

where P = number of people using the pit toilet

N = pit design life in years

C = rate of solids accumulation (m³/person/year)

Values for C vary from C=0,02 to 0,09 m³/person/year. The recommended freeboard for a pit is 0,5 metres. Thus 0,5 metres should be added to the depth of the pit. ⁽²²⁾

Analogous to the formula above Heap ⁽¹⁰⁾ presented the following formula to determine the design volume (V) of a pit:

$$V = C.P.N + 0,5 \text{ (m}^3\text{)}$$

where P = number of people using the pit toilet

N = pit design life in years (usually 10 to 15)

C = design capacity, m³/person/year (usually 0,04 for dry pits and 0,03 for wet pits)

The factor 0,5 provides for the fact that the top 0,5 m of the pit will be filled in with soil. These figures are suitable for cases where materials such as grass, maize cobs and cement bags are used for cleaning and thrown into the pit, and may be reduced by 30 percent in cases where paper is used. The wet pit figures also apply for dry pits where the interior of the superstructure is regularly washed down or used as a wash room. ⁽¹⁰⁾

An accumulation rate of 0,087 m³/person/year for a dry pit and 0,021 m³/person/year for a wet pit is recommended by Evans. ⁽⁶⁾

In Zimbabwe the pits were initially designed with a capacity of 0,087 m³ per person per year. This is now realized to have been much too conservative. In family toilets examined in Zimbabwe, sludge accumulation rates rarely exceed 0,02 m³ per person per year where the toilet is regularly washed down and paper of some sort is used for anal cleansing. This figure rises when the pit is always dry or when solid objects are used for anal cleansing. ⁽²⁴⁾

The pit should be made as large as practically possible and generally not less than 3 m³ in effective volume. ⁽²⁶⁾

Assuming that a toilet is used until the pit is full to within 0,5 m below ground level, a 1,5 m diameter pit, 3 m deep should last a family of six for approximately 35 years if it is regularly washed down and 20 years if it is a dry pit. ⁽²⁴⁾

The pit for the rural spiral model in Zimbabwe has dimensions 1,5 m x 0,6 m x 3 m deep; it lies with the longitudinal axis in a north-south direction in order to permit the correct orientation of the superstructure opening. ⁽²⁴⁾

In Lesotho the fully lined VIP pit has a top area of 0,9 m x 2,2 m. At a depth of 1,85 m it should accommodate a family of six for eight years (accumulation rate of 0,06 m³ per person per year). ⁽¹⁷⁾

A pit with a diameter of 1,7 m and 3,5 m deep should last a family of ten for 15 and more years. ⁽⁶⁾

The section area of the pit varies from 0,8 m² to 1,8 m². ⁽¹⁰⁾ Usually the pit cross-sectional area is not more than 2 m² in order to avoid cover slabs with large spans. Commonly pits have a diameter of 1 to 1,5 m or a width of 1 to 1,5 m in the case of square or rectangular pits. ⁽¹⁶⁾

The total depth is the depth required by the effective volume plus the desired free space of 0,5 m. ⁽¹⁶⁾ It usually varies from 3 m to 8 m. ⁽¹⁰⁾

For a VIDP toilet the design capacity of a single pit (V) may be calculated as follows:

$$V = 0,25P \text{ (m}^3\text{)}$$

where, P = number of people intended to use the toilet

The lifetime of each pit is usually two to three years and has a depth of between 1 m and 1,5 m. ⁽⁶⁾ With shallow pits, however, more frequent desludging of the pits becomes necessary. ⁽¹²⁾ Each pit should have a capacity to allow the family two to three years use before becomes full. ⁽²⁾⁽³⁾

Each pit for the VIDP toilet in Lesotho has an area of 1,02 m² and a depth of 1,5 m. Using the accumulation rate of 0,06 m³ per person per year it gives a life of 3,4 years for a family of six. ⁽⁷⁾

8.4 Pit lining

For the purposes of pit design, soils can be considered as either stable or unstable. The stability of the soil is defined as resistance to collapse. ⁽¹⁶⁾

Only the upper parts of the pit need be lined to support the slab in stable conditions. ⁽⁶⁾ Rivett-Carnac ⁽³²⁾ recommends that the pit should be lined to a depth of at least 0,5 metres from the top with masonry or concrete, while Evans ⁽⁶⁾ recommends plastering the top 1,0 to 1,2 m of the pit. In very firm soils the pit wall can be adequately lined to a depth of 1 m by plastering a 10 mm layer of cement mortar (1 cement : 5 sand ⁽¹⁶⁾) directly onto the soil face. ⁽¹⁶⁾⁽²⁴⁾

For a wet pit the lower quarter and bottom of the pit is lined to retain water. If it is partly lined to ensure that there is always water present, the decomposition of excreta is more rapid and more complete, thus considerably extending the life of the pit. ⁽²⁸⁾

If the material beneath the surface is of shale or layered rocks, the whole pit need not be lined and the wall can be plastered direct, as necessary. Where the soil consists of firm semi-weathered rocks (hard to pick), the wall can be plastered. ⁽⁸⁾

In less stable soil or in shallow groundwater areas it is necessary to extend the lining to the base of the pit. ⁽⁶⁾⁽²⁴⁾ and to support it upon suitable foundations. ⁽²²⁾ If the pit is not fully lined in unstable soils there is the risk that the pit will collapse and the superstructure may fall into it. ⁽¹⁶⁾

A variety of materials can be used to line the pit (Figure 8.1). Examples of such linings include concrete blocks, open-jointed brickwork, cement-stabilized soil blocks, masonry, stone rubble, perforated oil drums, rot-resistant timber and wire-mesh-supported geofabrics. ⁽¹⁵⁾⁽¹⁶⁾⁽¹⁰⁾ The lining may also consist of self-supporting bricks or a thick layer of plaster. ⁽¹⁰⁾

If there are large amounts of sand, silt or uni-granular material, or a mixture of all three, or material is loose and fails when lightly touched, then the pit must be lined in brick or stone. ⁽⁶⁾

Where blocks, bricks, masonry or stones are used, the lining joints should be fully mortared in the top 0,5 m of the pit. Below this, the vertical joints should be left unmortared to allow the liquid fraction of the excreta to infiltrate into the soil.⁽¹⁶⁾ Except for the top 400 mm to 600 mm (upper three courses or 300 mm⁽¹²⁾), the lining must be grooved so that liquids can be drained.⁽¹⁷⁾ Special care must be taken to ensure that the holes are not too large, where the soil is very sandy for instance, as it may be washed into the pit. It may sometimes be necessary to provide a gravel filter layer around the pit lining to prevent this.⁽²⁵⁾

Rats consider excreta as a food source. Not only does this create a possible transmission route for disease but the rats deposit large volumes of soil in the pit which rapidly fill it. A full lining of the top 0,5 to 1,0 m of any pit should prevent rats from entering.⁽⁹⁾

The pit contents must not be washed out onto the ground as is common during rainy weather. The top sections of the pit walls should be impervious to the passage of water. Any protrusion of the pit walls above ground level should be protected by an earth bank.⁽²⁸⁾

If the surrounding soil is very fine sand, a thin packing of fine gravel should be placed between the soil and the lining to prevent the sand from entering the pit.⁽¹⁶⁾

Where the groundwater table is permanently high, short lengths of concrete pipe with sufficient holes for infiltration, inserted as excavation proceeds, works satisfactorily. Perforated oil drums coated with bitumastic paint are an alternative, but corrosion is a problem in the long term.⁽¹⁶⁾

Lining is essential if the pit is to be emptied mechanically or manually, if excessive water (bucket showers) enters the pit, if the superstructure has to be heavy or if the toilet has to be raised. Although lining increases the structural stability of the toilet, it increases construction costs and makes construction difficult in areas of permanently high groundwater.⁽¹⁸⁾

The lining should be capable of supporting the reinforced concrete cover slab, the superstructure and dead as well as live loading.⁽²²⁾

The lining should extend at least 75 mm above natural ground level.⁽²²⁾

There must be no cross ventilation between the two pit compartments of a VIDP toilet. Therefore the central diving wall must extend the full depth of the pit and be supported by sound foundations. The jointing of masonry must be with mortar and must be well sealed with respect to both water and air movement.⁽²²⁾

8.5 Pit collar

The top of the pit must be reinforced by means of a collar to prevent collapse and the ingress of surface water.⁽¹⁷⁾⁽²²⁾⁽²⁶⁾ Only where a dry pit is dug in very stable soil and the cover slab has sufficient support all around, might the pit collar be unnecessary.

The collar forms the foundation of the cover slab and is generally a simple ringbeam of reinforced concrete or, more commonly and less expensive, bricks or stone set in cement mortar (Figure 8.2). A single course of bricks, laid on the ground surface with their inner edges flush with the pit wall may also be sufficient.⁽¹⁶⁾ Evans⁽⁹⁾ suggests that approximately 45 bricks cemented end-on in a complete circle be used as a collar to support the slab and protect the pit from erosion.

Setting the foundation on top of the ground surface enables a gentle grass slope or cement-stabilized soil bank to be constructed to divert stormwater which might otherwise erode the upper part of the pit wall.⁽¹⁶⁾ Where the pit is lined with masonry, it can be extended another course above ground level to form a heaved pit collar.

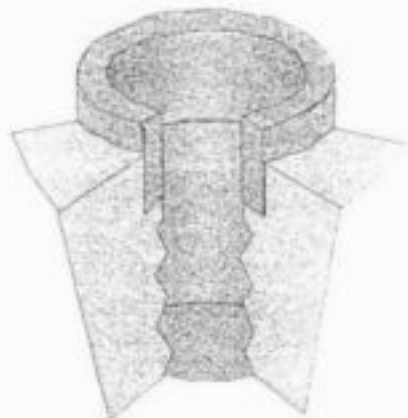

(a) Concrete pit collar*

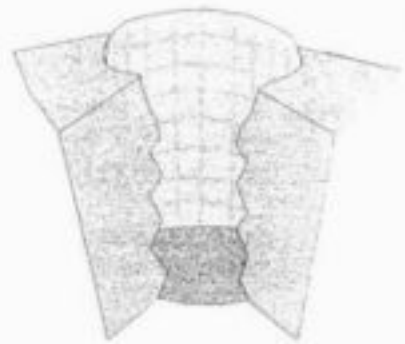

(d) Wire mesh and geofabric pit lining

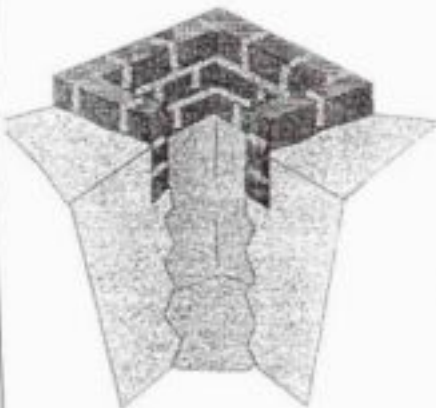

(b) Brickwork pit collar *

* Extend to bottom of pit where full lining is required



(e) Perforated oil drum lining (Temporary use only)

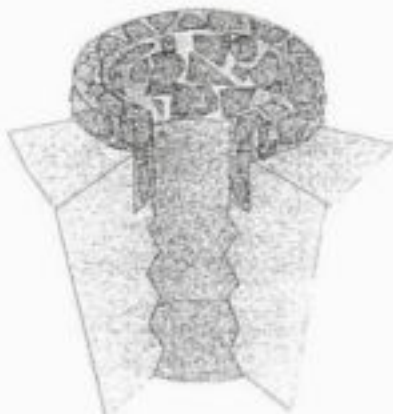

(c) Stone pit collar *

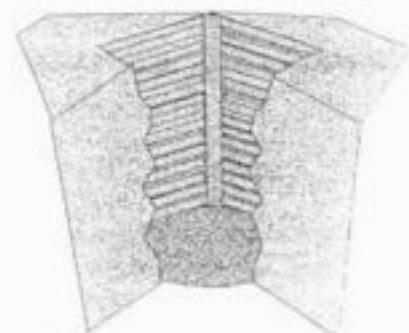

(f) Pit lined with treated poles

Figure B.1: Typical pit linings

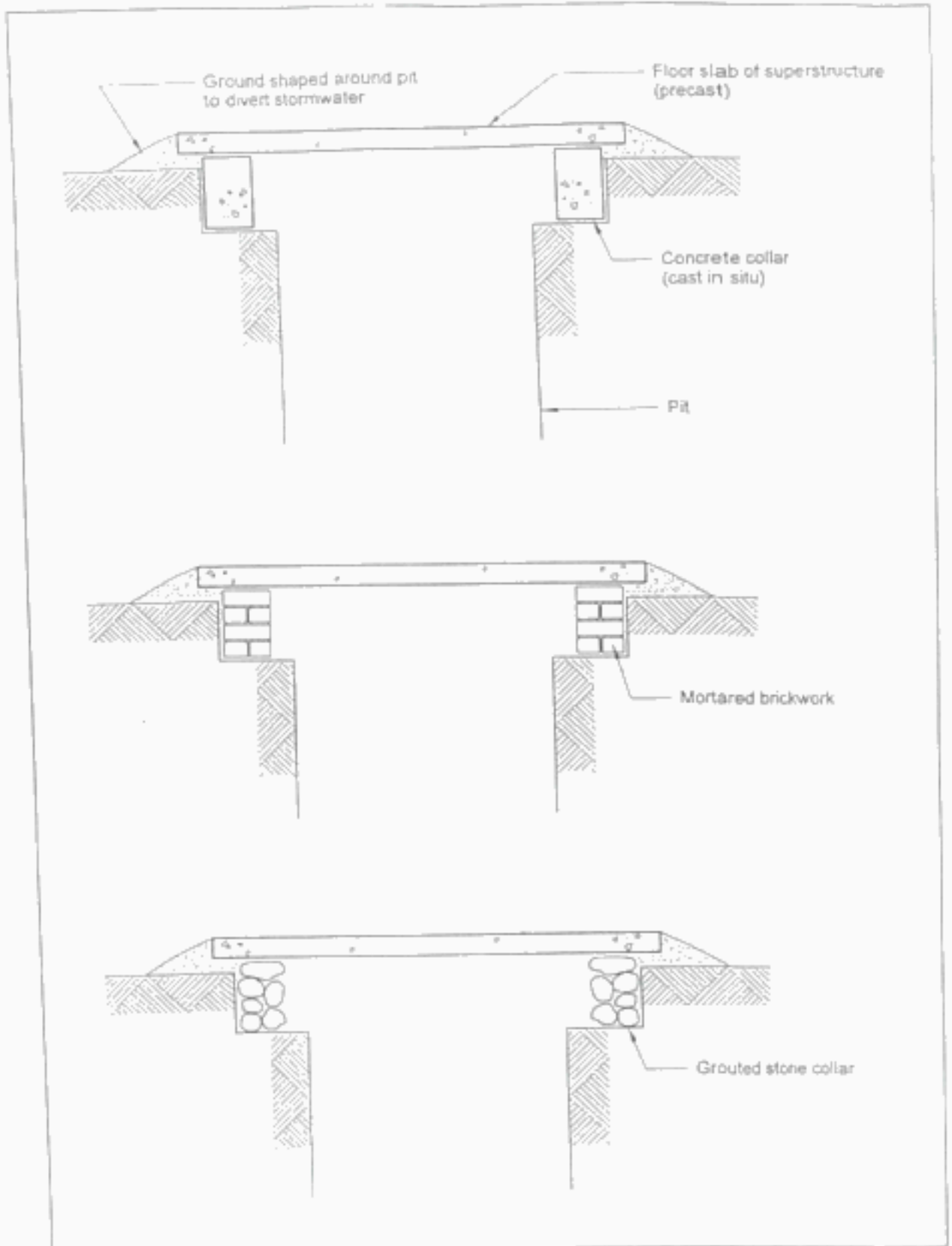

Figure 8.2: Typical pit collars

9. Cover slabs

9.1 General

Important factors to consider in deciding on a cover slab are the ease of quality control, and the use of available materials. ⁽¹⁾

The cover slab over the pit should be properly supported. If the slab rests on bare earth (where the pit is without a pit collar), it needs about 200 mm wide support all around the pit, for example a 1100 mm diameter pit requires a 1500 mm diameter slab. On a good base, such as the top of a brick lining or other type of pit collar, 50 mm width of support is enough. ⁽²⁾ The cover slab should be flush with the outer edge of the foundation or pit collar. ⁽¹⁾⁽³⁾

Various materials may be used for the slab. A reinforced concrete slab cast in-situ, a brick arch slab or treated poles can be used to cover the pit. ⁽⁴⁾ Ferrocement slabs or flat domes can also be used. ⁽³⁾

If reinforced concrete cover slabs are used, the slabs should be designed to compensate for deficiencies in the precasting operation (poor quality control and curing ⁽¹⁾⁽³⁾) and for overloading, such as storing heavy building materials on them. ⁽⁴⁾ Large slabs should be constructed in sections or panels, so that each part can be lifted by two men. Each section should be at least 600 mm wide, however, to allow enough room for pit emptying operations. The removable panels usually come with handles made of reinforcing steel to lift them. ⁽³⁾ These panels should be sealed with weak mortar to ensure an insect-proof joint. ⁽¹⁾⁽³⁾

Concrete slabs can be made in-situ or can be precast. Precast slabs are reinforced with 6 mm steel bars spaced 150 mm apart or 8 mm bars spaced 250 mm apart, in both directions. This is sufficient for a 80 mm thick slab spanning up to 1.5 m. ⁽³⁾ The slab can be rectangular or circular. Circular slabs have the advantage that they can be rolled into the correct position. ⁽³⁾ Slabs are usually over-designed by engineers and are too heavy. Mvula Trust recommends a 75 mm thick slab, reinforced with 6 mm bars at 150 mm centres. ⁽⁴⁾⁽⁵⁾ Coarse aggregate is not essential, provided clean river sand is available, a perfectly acceptable slab can be cast using a 5:1 cement sand mix. The slab should be kept damp for at least 5 days. ⁽²⁾

Removable cover slabs are essential if the pit needs to be emptied. The seat opening is not big enough for this purpose. ⁽⁴⁾

Ferrocement slabs, made of cement reinforced with wire mesh may be thinner, lighter, and easier to handle than concrete slabs. To construct such a slab two to four layers of chicken wire are plastered with a rich cement mortar to about 20 mm (i.e. a total thickness of 40 mm). ⁽³⁾

Slabs can be cast as flat domes with no reinforcement. They are strong enough to support their own weight as well as the weight of users. Domed slabs 1500 mm in diameter can be made 40 mm thick at the edges, with the bottom face rising by 100 mm at the centre.

Another option is a slab constructed of self-supporting building blocks. There is also no reinforcing used in this case and the construction can be completed very quickly. ⁽¹⁾

Logs and bamboo are often used to make the slab. If timber poles are used, they should be protected against rot and termite attack by soaking in used oil. They are covered with a layer of gravel and/or mud finished to a smooth, hard surface. ⁽¹⁾⁽³⁾

Other materials that are suitable for use are sawn timber, metal sheets (for example, old advertisement signs), natural stone, and brick arches. The chassis of an abandoned car or lorry makes a good support for a slab, and the slab itself may be made from flattened car doors and other scrap material. ⁽³⁾

The floor slab must be at least 75 mm (not higher than 1 m for raised VIP toilets) above ground level ⁽¹⁴⁰⁾ and well sealed to prevent an ingress of surface water. ⁽¹⁴²⁾ (Figures 8.2 to 8.4)

The cover slab has two holes, namely one for the squat-hole or pedestal and one for the vent pipe. Where the preferred posture is squatting, a 5% slope towards the hole in order to provide drainage for urine and water, is recommended. Although foot-rests are not necessary, they may be socially required. ⁽¹⁴¹⁾

An effective way of ensuring that a slab is strong enough to support the heaviest users is for five men to stand on it, while it is supported at the corners with bricks. It should not crack under these conditions. ⁽¹⁴²⁾

9.2 Orientation

In placing the cover slab, the openings in the slab should be orientated so as to correctly position the vent pipe relative to the superstructure.

Before placing the cover slab, the direction in which the entrance of the toilet should face (preferably within the arc between southwest and southeast to avoid sunlight entering directly into the toilet) should also be considered. ⁽⁸⁾

10. Superstructure

10.1 General

The function of the superstructure is to provide the user with privacy, comfort and shelter against the weather. It should exclude vermin and be compatible with the exterior of the house. ⁽⁴⁾ The structure should be waterproof to stop rainwater from getting into the pit and flooding it ⁽³¹⁾ and it should be constructed so as to inhibit the ingress of surface water. ⁽⁴²⁾ To prevent flies which may have entered the pit from being attracted into the superstructure, the inside of the superstructure should be fairly dark. ⁽¹⁰⁾⁽³²⁾⁽¹⁶⁾ Thus it should provide sufficient shade and it must channel air through the squat-hole and up the vent pipe, in order to control flies and faecal odours. ⁽¹⁸⁾

Users of the toilet may fear the dark interior, and possible lurking insects or small animals. It seems, however, that some light can be admitted without affecting the fly-catching, provided that the vent pipe is large enough, and the screen is kept clean. Residents in communities often have some form of electrical connection, and so a bulb outside the toilet can also provide reassurance at night. ⁽¹⁷⁾

From the health point of view the superstructure is less important than the pit and slab, ⁽⁶⁾ but the toilet must be attractive and well built in order to encourage its use. ⁽³²⁾

The superstructure can be built in a wide variety of forms and with many different materials. The design adopted depends on social preference, affordability and the availability of material. ⁽¹⁶⁾⁽³⁷⁾ Making use of contemporary and traditional building materials and techniques encourage self-help building practices. ⁽³⁷⁾ Construction techniques that are familiar to local builders will generally be preferred to ones requiring special skills training. ⁽²⁶⁾

There are two possible basic shapes, namely, a simple rectangular box, with or without a privacy wall, and a spiral, which may be round or rectangular. Although the spiral design uses more wall materials (while allowing the possibility of saving on the possibly more expensive door and hinges), it has the advantage of keeping the inside of the building partially dark and is therefore more suitable for ventilated pit toilets. ⁽⁹⁾

As part of this research project, the Division of Building Technology carried out some indicator tests to determine whether the various superstructure patterns had any effect on venting efficiency. Simple

tests were performed under controlled conditions in a laboratory, using 1:5 scale models of the rectangular box, the round spiral and the rectangular spiral toilets. A simple fan was used to simulate different wind directions and chemicals were used to produce white fumes in the pit, which simulated the odorous gases emanating from the pit contents. The different models were visually inspected and analysed for back-venting under various circumstances.

The tests indicated that the rectangular box shape superstructure performed well except when the roof angle was raised so that the higher end was above the top of the vent pipe, when back-venting occurred. This emphasized that the top of the vent pipe should always be higher than the highest point of the roof.

The rectangular spiral superstructure performed well in all the different wind directions, whether its roof was extended over the entrance to the privacy wall or not. The round spiral shape, however, did not perform well. Substantial back-venting occurred with almost all wind directions except when the wind blew more or less directly into the entrance and the air flow was thus scooped into the superstructure. For this reason the round spiral shape superstructure should be used with caution.

Many different materials can be used for the superstructure. The permanence of the structure should be considered when construction methods and building materials are decided upon.⁽¹⁰⁾ Locally available materials should be used as far as possible, as transport of materials is usually a problem.⁽⁴³⁾⁽⁴⁷⁾ The materials used should preferably match the house, because it makes maintenance by the owner easier and is aesthetically better.⁽⁴⁷⁾

Examples of different materials are (Figure 10.1):⁽¹⁰⁾

- Wattle and daub hut with a corrugated iron or thatched roof
- Timber walls and corrugated iron or asbestos roof
- Brick walls and tile, corrugated iron or asbestos roof
- Rough-cut tree limbs and logs
- Steel mesh covered with hessian, with a sand-cement mixture applied to the framework⁽¹⁰⁾

Screens and fences made from grass, grain stalk or woven palm can be used. It should be noted that a VIP design needs a roofed and partially darkened superstructure, thus screens and fences alone, without walls or a roof, will not be ideal.⁽⁹⁾

In many areas housing consists of mud and wattle, i.e. upright poles with the bark removed, interwoven with small branches, the whole structure being plastered with mud. Mud and wattle may be improved by nailing bamboo strips to straight upright poles and filling gaps with small stones before plastering with mud.⁽⁹⁾

Shelters can be made from larger diameter bamboo poles forming the main frame, with smaller bamboos nailed or strapped to them to form the walls. Alternatively palm leaves or bamboo matting can be used to fill in the walls of the bamboo frame.⁽⁹⁾

Increasingly, sawn timber is becoming an expensive and rare commodity in low income areas, but if off-cuts are available from a saw mill, these can be used to clad a simple timber-framed structure.⁽⁹⁾

Bricks made from a mixture of well-puddled and tempered clay, formed in wooden formers, or machine-pressed blocks can be used. They can be strengthened with the addition of natural fibres, such as fine grasses.⁽⁹⁾ During the Mvula Trust pilot projects the householders made the bricks themselves.⁽⁴⁷⁾

Brick, blockwork or ferrocement is often used in urban areas, and local available materials such as mud and wattle, thatch or sun-dried earth blocks in the rural areas.⁽¹⁰⁾ Two popular designs of the VIP toilet include a concrete block superstructure and a framework covered with chicken wire, hessian and cement mortar.⁽³⁸⁾

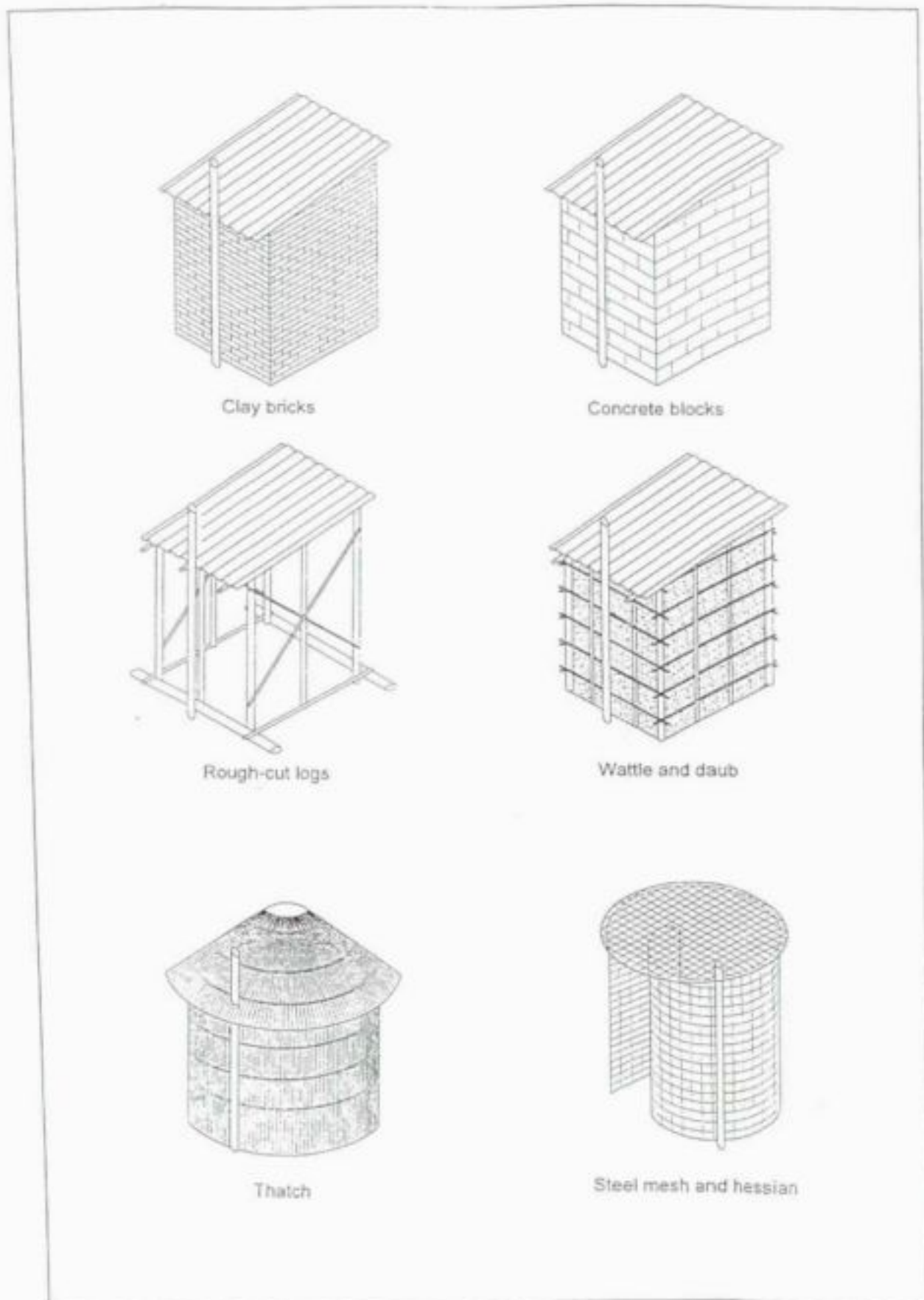

Figure 10.1: Typical VIP toilet superstructures

The different superstructures are divided into two categories, namely, temporary or removable structures and permanent structures. The temporary structure is manufactured with available indigenous materials (thatch, reeds or saplings). There are also a number of commercially available lightweight portable superstructures prefabricated from GRP or moulded plastic. Moulded ferrocement, corrugated iron, galvanised iron sheet and timber are some other building materials which are used for temporary structures. Blocks or bricks are used for the more permanent structures. ⁽³²⁾

Where the pit is not emptied, the superstructure should preferably be constructed so that it can be moved to a new location when the pit fills. Because the VIDP is a more permanent structure than the VIP, more permanent building materials are often preferred for this version. ⁽³³⁾

The floor area of the superstructure of a VIP toilet should be between 0,8 m² and 1,5 m². Mvula Trust recommends that internal dimensions should be at least 750 mm x 1000 mm. ⁽³⁴⁾ For the VIDP toilet the plan area should be 2,35 m² minimum. ⁽⁴⁾ The height should accommodate a person standing upright without his or her feeling oppressed by the roof (at least 2 m high ⁽¹⁰⁾).

If the toilet is in an open field the superstructure must be rigid and not collapse if a cow rubs against it. ⁽⁴⁵⁾ The privacy wall is often pushed over by cattle and should be provided with an extra corner at the end of the wall for stability purposes. ⁽⁴³⁾

As part of Mvula Trust's pilot sanitation project a VIP toilet of ordinary brick and mortar was built. It has had widespread acceptance, not because it is anything particularly special, but simply because it is robust, has a roof, a white uPVC pedestal that looks exactly like an ordinary ceramic pedestal, and is aesthetically pleasing. ⁽²⁴⁾

10.2 Location and orientation

The superstructure need not be constructed wholly over the slab, as long as it accommodates the squat-hole, or hole for the pedestal, and vent pipe hole. ⁽⁸⁾

Preferably the toilet should be to the rear end of the plot. ⁽³⁷⁾ The toilet should be situated in a place where it is convenient to empty. ⁽⁴⁾

The toilet should not be under or close to trees, as these interfere with the proper operation of the vent pipe. Where the prevailing wind direction is known, it should also not be upwind and within 10 metres of the dwelling in order to prevent foul air from reaching the latter. The use of a taller vent pipe (3 m) might help prevent foul air from reaching the dwelling. ⁽⁸⁾

The door or the opening of the spiral structure should not face either east or west in order to prevent direct sunlight from entering the toilet. ⁽²⁴⁾⁽³⁷⁾ The rectangular spiral superstructure should be orientated so that no direct sunlight reaches the seat. ⁽⁴³⁾ It should face either north or south, decided by the relative positions of the house and the toilet, in order to provide maximum privacy. It should preferably face the house. ⁽²⁴⁾⁽³⁷⁾

In some cultures there may be a prohibition on facing in a particular direction when defecating. This must obviously be taken into account when the toilet is being positioned. ⁽⁸⁾

The superstructure should not be part of the house. When it is cold outside, the interior of the house might warm up the superstructure. Back-venting will occur if the temperature inside the superstructure is higher than the temperature of the vent pipe.

10.3 Walls

The walls must be waterproof and also provide sufficient privacy for the user. They should also keep out vermin and blend with existing building styles. ⁽¹⁷⁰⁾

A toilet that is bright and light is more attractive to its users, but a ventilated pit requires a partially darkened superstructure. However, the internal walls of the superstructure may be whitewashed and some light allowed through ventilation openings. ⁽⁹⁾

Galvanised wire with two free ends should be incorporated into the wall construction in order to tie the vent pipe and the roof to the superstructure. ⁽⁸⁾

Reducing the heat gain of the superstructure adds to the efficiency of thermal convection effects ⁽⁷²⁾ and provides more comfort for the user. Therefore the use of bad conductors of heat, such as ferrocement and bricks, is preferred. Because galvanised iron sheeting and PVC are good conductors of heat, using these materials for walls is discouraged. In Lesotho, however, where hot windless days do not occur often, iron sheeting is used for the superstructure. ⁽⁴⁸⁾

According to Evans ⁽⁸⁾ the walls of the superstructure should be laid with brick and a mortar mix (5:1). The portion of wall overlapping the ground must have a 250 to 350 mm wide foundation for support. ⁽⁸⁾ A brick wall across the cover slab will generally support a large proportion of its own weight, but as corners in such a wall may induce concentrated stresses in the slab, cornering on the slab should be prevented. ⁽⁴⁶⁾

Morgan also advised that the interior walls be painted to a height of approximately 50 cm with black bitumastic paint. ⁽²⁴⁾

The use of bricks or blocks for walls is preferred to corrugated iron in South Africa. ⁽⁴⁷⁾⁽⁴⁵⁾ Although ferrocement may be slightly cheaper it is not advised ⁽⁴⁷⁾⁽⁴⁵⁾ because of some people's tendency to make spyholes in it and pick off the plaster. ⁽⁴⁵⁾⁽⁴⁴⁾ Fibreglass and PVC superstructures are too expensive and may be badly damaged in windstorms. ⁽⁴⁵⁾

10.4 Door

The door of the superstructure should preferably face the house. The door should not face west or east so as to prevent direct sunlight from entering the structure, which should be kept as dark as is practically possible. ⁽²⁷⁾ The flow of air is increased if the doorway and the ventilation openings of the superstructure face the prevailing wind. ⁽⁹⁾⁽²⁵⁾

Doors can be made from beaten tins or corrugated iron on a wooden frame, bamboo strips, wood or anything else that is available. ⁽⁸⁾ Timber doors should be painted, varnished, or given some other protective treatment such as engine oil. Untreated doors do not last in local weather conditions. ⁽²⁶⁾

The door can open inwards or outwards depending on the user's preference. If it opens outwards the interior floor area of the toilet can be minimized, thus the superstructure can be less expensive. A door opening outwards can, however, be damaged by the wind more easily than one opening inwards. ⁽¹⁸⁾⁽⁴⁵⁾ A door opening inwards permits a larger interior, which make it easier to work inside when cleaning the toilet. ⁽⁴⁷⁾ Contrary to normal building practice, the door is usually designed to open outwards to increase the usable space inside the superstructure and to avoid hitting any footrests. This may not be practicable in grass-roofed structures with low eaves. In some cultures a privacy wall is required to screen the door. ⁽⁶⁾ Rivett-Carnac ⁽²²⁾, Heap ⁽¹⁰⁾ and De Villiers ⁽⁴⁾ suggest that the door should open to the outside to minimize the interior floor area. It should be lockable on the outside and a catch should be provided on the inside for greater privacy. ⁽¹⁰⁾⁽⁴⁾

If a door is fitted it should be kept shut at all times in order to keep the inside of the toilet reasonably dark. ⁽⁹⁾ If it is left open, flies in the pit will leave via the pedestal or squat-hole because of the source of bright light. Self-closing doors can be used (counterweight). Alternatively, the toilet should be locked on the outside. ⁽¹⁰⁾

Where possible it is advisable to mount the door on self-closing hinges. Hinges do not have to be manufactured in steel. Strips of old car tyres or leather from old shoes can be used equally well. ⁽¹¹⁾

In Zimbabwe doors were considered undesirable, not only because they were frequently left open, with resultant poor fly-control, but also because wood is expensive, hinges rust and occasionally the doors were removed and chopped up for firewood. ⁽¹²⁾ Thus where a door is considered unnecessary, the Zimbabwe spiral VIP toilet may be used. This simplifies construction and also eliminates door maintenance. ⁽¹³⁾

10.5 Roof

The roof must be waterproof to ensure user comfort. ⁽¹⁴⁾ It must be adequately tied into the walls of the structure, which must be strong enough to resist the uplift forces caused by high winds. ⁽⁹⁾

Materials such as thatch, palm leaves, clay tiles, fibre-cement tiles, wood shingles, corrugated iron, corrugated aluminium, asbestos cement, ferrocement and precast concrete can all be used for roofing the toilet superstructure. ⁽⁹⁾

The roof should preferably slope away from the door, as a roof sloping towards the door might obstruct the opening and closing of the door or shower the users in rainy conditions.

Some materials, for example, galvanized corrugated iron, lead to greatly increased temperatures inside the toilet which may increase odour and make the building unpleasant to use. ⁽⁹⁾ Evans suggests that a 25 mm thick concrete slab reinforced with chicken wire be used as a roof. ⁽⁶⁾ A ferrocement slab (30 to 40 mm thick) has the advantage that no timber or fixings are required; it is moreover durable and unlikely to be stolen. ⁽²⁶⁾

10.6 Ventilation openings

The toilet must afford complete privacy to the occupant, while maintaining ventilation. ⁽³²⁾ Therefore permanent ventilation openings should be provided to improve ventilation through the superstructure. ⁽¹⁰⁾

Inlet vents are most effective when they face the prevailing wind and should preferably be at a different height from the outlet in order to improve the efficiency of air exchange. Where there is a fairly constant prevailing wind, any openings should be on the windward side to ensure maximum air movement through the pit. However, where the prevailing wind is variable, it may be necessary to have other openings in the structure to prevent a suction effect when the wind blows from a different direction. Such a suction effect can lead to back-ventilation. ⁽⁹⁾⁽³⁴⁾ It is extremely important to avoid openings on opposite sides, as this would significantly reduce the pressure difference which causes updraught in the vent pipes. ⁽¹⁶⁾

The ventilation openings should preferably be screened and should be left at the top of the walls or between the top of the door and the roof. ⁽⁴⁾

The minimum size of the ventilation opening(s) should be at least three times the cross-sectional area of the vent pipe to allow for head losses in the superstructure. ⁽⁹⁾⁽¹⁰⁾⁽¹³⁾⁽³⁴⁾

A minimum requirement of about six complete air changes of the superstructure per hour (10 m³/h) has been recommended by Ryan and Mara. ⁽²⁴⁾ An opening of at least 0,15 m² should be adequate in most climates. ⁽⁹⁾

11. Seat

A squat-plate or a seat in the form of a bench or a pedestal should be provided in the superstructure. The beneficiaries should decide which option they prefer. ⁽¹⁰⁾⁽²²⁾

In Botswana people prefer to sit rather than squat. ⁽²⁷⁾ Sitting is also preferred to squatting in Zulu communities, while in Asian communities squat plates are normally preferred. ⁽²²⁾ Bench seats are used in Lesotho. ⁽¹⁾⁽⁴⁸⁾

The squat-hole is normally key-shaped or pear-shaped with a maximum width of 200 mm to prevent children from falling in. ⁽¹⁶⁾ It is usually about 400 mm long, and about 180 mm wide. Foot-rests are often provided and they are usually raised about 10 mm above the surface of the slab. They enable users to find a good position for squatting, which is especially helpful at night. ⁽²⁰⁾

In South Africa most people want a proper pedestal and the use of squat plates is not advised. ⁽⁴⁴⁾⁽⁴⁵⁾⁽⁴⁷⁾ Where seating is preferred a bench seat or pedestal will be necessary, of which bench seats would be cheaper. ⁽²²⁾ The seat support can be made on site from brick, concrete, mud block or timber. Commercially available or project-manufactured pedestals made of ceramic, glass-reinforced plastic (GRP), PVC or ferrocement can also be used. ⁽⁹⁾⁽³⁰⁾

Moulded seats made of ferrocement fitted with a plastic seat cover are not recommended. The seat covers often get stolen and the seats are uncomfortable to sit on. People then sometimes defecate inside the toilet on the floor slab. ⁽⁴⁴⁾

The upper opening of the seat should be large enough to minimize fouling of the bowl and the lower opening small enough so that children will not fall into the pit. ⁽³²⁾⁽³⁷⁾ The seat level should be at a position that is comfortable for the majority of the users. This is normally about 350 mm above the top of the slab. ⁽⁹⁾⁽³⁰⁾ The hole in the seat is commonly 250 mm wide. Children may be frightened by a large opening, so a separate hole with a smaller diameter may be provided for them. This seat may be built lower or a block, suitably placed for the children's feet, can be fitted. ⁽³⁰⁾ Analogous to this Heap ⁽¹⁰⁾ suggested that the seat height should be between 400 mm and 500 mm and an opening of 250 mm to 300 mm is suitable for adults. An extra seat cover (opening not bigger than 200 mm) for children should be provided. ⁽¹⁰⁾

The prefabricated pedestal should be of adequate strength and rigidity. It should not be higher than 450 mm, with an upper opening which is large enough (310 mm) to minimise fouling of the pedestal and a lower opening small enough (210 mm) to encourage parents to let their children use the toilet without fearing that they will fall in. ⁽²⁸⁾

The inside of the pedestal should be designed to prevent constant fouling by excreta. One approach is to use a large-diameter opening of 250 mm or more, but this might discourage use by children who are frightened by the large opening. An alternative is to have a 180 mm diameter hole through the pedestal which is lined with a smooth material. A third alternative is a tapered hole, increasing from an opening size of about 180 mm at seat level to 300 mm at the slab. A special filment with a small opening can be made to encourage children to use the toilet. Alternatively the pedestal top can be enlarged to accommodate a second seat with a smaller opening, possibly at a lower level, for use by children. ⁽⁹⁾

Contact between excreta and concrete should preferably be avoided. A plastic bucket with the bottom removed may be used as a funnel to line the seat pedestal and provide a cheaper alternative to a proprietary plastic pedestal unit. ⁽²⁸⁾

It is important that the squat-hole is not kept tightly closed when the toilet is not in use. Whereas the traditional toilets relied on covers to control fly breeding, it is not only unnecessary in the case of VIP toilets but also positively detrimental to their operation. ⁽¹⁸⁾⁽²⁴⁾ If the superstructure is kept reasonably dark inside, a squat hole cover plate is unnecessary. If the superstructure is not dark, a suitable cover can be made of plywood and so shaped as to fit between the footrests. Strips of wood of 25 mm square cross-section must be screwed to the underside of the longitudinal edges of the cover in order to permit the free passage of air. If a seat cover is used with pedestal seats, small blocks of wood, 25 mm thick, should be screwed to its underside at the front for the same reason. ⁽²⁴⁾ Rivett-Carnac ⁽³²⁾ suggests a minimum gap of 15 mm around the circumference of the toilet seat, between the seat and the closeable cover, while Heap ⁽¹⁰⁾ suggests that spacers of 15 mm to 20 mm would be sufficient.

12. Vent pipe

The vent pipe must be designed so that it can induce sufficient air flow through the toilet to leave the superstructure odour free. Under-design of the vent pipe will normally cause problems in odour and insect control, while over-design will increase costs unnecessarily. ⁽²⁴⁾

A vent pipe covered by a fly screen, combined with a relatively dark interior to the superstructure, will:

- eliminate faecal odours in the superstructure ⁽¹⁸⁾
- prevent most flies from entering the pit ⁽¹⁸⁾ and thus reduce the amount of fly breeding in the pit ⁽⁷⁾
- prevent flies which have managed to breed in the pit from escaping. ⁽¹⁰⁾⁽⁷⁾

Uninterrupted ventilation by means of air flow down the pedestal or squat-hole and up through the vent pipe should be maintained. ⁽³²⁾ There are two possible mechanisms for maintaining the circulation of air through the toilet system, namely, the thermal effect of solar radiation on the vent pipe's external surface, and the suction effect of wind across the top of the vent pipe. ⁽³³⁾⁽³⁶⁾

Studies in Botswana and Zimbabwe showed that the two most important factors governing the ventilation rate are the local wind speed and its direction. Thermally induced updraft caused by the absorption of solar radiation by the external surface of the vent pipe was found to be of relatively minor importance. ⁽³³⁾⁽³⁴⁾⁽⁹⁾⁽¹⁰⁾

The vent pipe should be painted black, and fitted on the sunny side of the toilet so it can heat up and create an updraft. ⁽⁷⁾ However, it was found that blackening the external surface of the vent pipe had only a very small effect on increasing the venting efficiency, but this factor may be of greater importance under windless conditions. ⁽³³⁾ In areas where the local wind speed is less than 0,5 m/s, the external surface of the vent pipe should be painted black in order to increase the magnitude of the thermally-induced venting. In areas where the mean wind speed is above 0,5 m/s the colour of the vent pipe is not important. ⁽²⁴⁾ Thus, although painting the vent pipe black and orientating it towards the sun helps to create thermal convection currents during sunny windless days, it is not essential. ⁽³²⁾⁽⁴⁷⁾⁽²⁶⁾

The direction of the wind relative to openings (doors, windows) in the superstructure was found to have a major influence on the ventilation efficiency. ⁽³²⁾

Wind speeds of 2 m/s and higher induce air velocities within the vent pipe of at least 0,7 m/s. Venting velocities were found to increase substantially when the toilet superstructure opening faced into the wind. ⁽²⁴⁾

After extensive monitoring of the ventilation performance of different VIP toilets in Zimbabwe and Botswana, members of the Technology Advisory Group (TAG) compiled preliminary design guidelines for the vent pipes of VIP toilets. All the toilets studied in Botswana and Zimbabwe were completely free of faecal odours, although a few of them had a slight odour of ammonia from urine splashes on the squatting plate. Odourless conditions were associated with vent pipe air flow rates of 10 m³/h and above, which seemed a reasonable minimum requirement in cases where costs must be kept as low as possible. A desirable design standard in urban programmes which provide permanent toilets located close to living quarters, would be 20 m³/s. ⁽³⁴⁾

Vent pipes should be straight to ensure entry of light into the pit to attract the flies. ⁽⁷⁾⁽¹⁰⁾⁽²⁵⁾ A straight pipe also maximizes the air flow, whereas bends in the vent absorb part of the energy in the air movement. With certain types of slabs, or where existing slabs require upgrading with a vent, there may be a need to bring the pipe out horizontally underneath the slab before turning to the vertical. In this situation an ancillary light source is required in the form of a glass or perspex window at the bend. ⁽⁸⁾

The vent pipe should preferably be located on the outside of the superstructure, since it is more difficult and expensive to ensure a rainproof and wind-tight seal between the roof and a vent pipe going through it. ⁽¹⁶⁾⁽²⁶⁾ Moreover, in areas where thermally-induced ventilation may be more important than that due to wind, the vent pipe must be placed on the outside of the superstructure. However, in urban areas, external vent pipes could be subject to damage by vandals, although, as yet, there have been no reports of this happening. ⁽¹⁶⁾

The vent pipe of the toilet should be located in the best position to utilize any air movements across the upper end of the pipe. ⁽⁹⁾ Thus it should be at least 2 m away from anything that might impede the action of the wind across the top of the vent pipe, such as existing trees and overhanging branches. ⁽¹⁶⁾⁽²⁴⁾⁽³⁷⁾

If there is no prevailing wind direction, the design of the vent pipe is of the utmost importance for adequate ventilation. ⁽¹²⁾ The vent pipe should be located on the side of the building which faces the equator, that is the side which receives most sunlight. ⁽⁹⁾ Therefore the vent pipes should preferably face northwards and not southwards in the southern hemisphere. ⁽²⁶⁾⁽³⁷⁾

Fixing cowls should not be used, as they reduce the wind shear at the top of the vent pipe by inducing turbulence. ⁽³⁴⁾ Rain cowls also reduce the air flow through the vent pipe and the amount of rain entering the pit is not likely to be significant and probably beneficial. ⁽⁹⁾

The vent pipe must be rigidly fixed to the superstructure and the cover slab. ⁽³⁴⁾ Galvanized wires should be used to tie the pipe to the wall and its base should be built up with cement mortar. ⁽³⁷⁾

A wide variety of different materials have been successfully used to form vent pipes, namely:

- asbestos cement (AC)
- polyvinyl chloride (PVC)
- unplasticized PVC (uPVC)
- bricks
- blockwork
- cement-rendered reeds
- cement-rendered hessian supported on steel mesh
- anthill soil
- bamboo with the cell dividers removed ⁽¹⁶⁾⁽³⁴⁾
- pitch fibre (PF)

Important factors in the choice of material are its durability, availability, cost and ease of fixing it in place. ⁽¹⁶⁾⁽³⁴⁾

Brick vent pipes have the advantage that they retain heat longer than either PVC or asbestos cement pipes and can thus maintain a thermally induced circulation of air well into the night. ⁽²⁴⁾ Thin galvanized steel sheet is not recommended as it is prone to corrosion. ⁽²⁵⁾ PVC pipes become brittle when exposed to high sunlight intensities; it is thus better to use PVC pipe made with a special stabilizer to prevent damage by ultraviolet radiation. ⁽¹⁸⁾⁽²⁴⁾⁽²⁶⁾

The following minimum vent pipe sizes are recommended for various applications.

Table 12.1: Recommended minimum internal size for various pipe material ⁽²⁴⁾

	AC or PVC	Brick	Cement-rendered reed or hessian
Permanent installations, mean wind speed below 3 m/s (design venting capacity 20 m ³ /h)	150 mm diameter	230 mm square	250 mm diameter
Permanent installations, mean wind speed above 3 m/s (design venting capacity 20 m ³ /h)	100 mm diameter	180 mm square	200 mm diameter
Rural installations, minimum cost urban installations	100 mm diameter	190 mm square	200 mm diameter

Recommendations for the minimum internal size of vent pipes by Mara ⁽¹⁶⁾ are as follows:

AC or PVC	150 mm diameter
Brick	230 mm square
Cement-rendered reed or hessian (and other rural types)	230 mm diameter

In exposed locations where wind speeds are greater than 3 m/s, the minimum diameter of AC and PVC pipes may be reduced to 100 mm, and to 200 mm in the case of rural vent pipes. ⁽¹⁶⁾

Evans ⁽⁶⁾ suggests that homemade pipes (brick incorporated in the superstructure, weldmesh and hessian, reeds, grass) should have an inside diameter of 280 mm to 300 mm, while an inside diameter of 150 mm is recommended for the manufactured pipes (PVC, AC, PF). ⁽⁶⁾

Circular vent pipes should normally have an internal diameter of at least 150 mm for smooth materials (PVC or AC) or 230 mm for rough surfaces (such as locally produced cement-rendered pipes), although in exposed places with high wind speeds a smaller diameter may be sufficient. ⁽⁸⁾

In Zimbabwe tests have shown that a vent pipe of 200 mm is much more efficient than one of 150 mm or 100 mm. ⁽¹⁰⁾⁽²³⁾⁽²⁴⁾ The minimum diameter of the vent pipe should be 100 mm for pitch fibre, asbestos cement or polyvinyl chloride, 200 mm for a homemade pipe of cement-coated thatch or reeds, and 180 mm for square brick shafts. If houses are closer together or the toilet is close to the house, diameters of 150 mm, 250 mm and 230 mm respectively, are recommended. ⁽¹²⁾ Diameters of at least 150 mm ⁽⁷⁾ and nominal diameter from 110 mm to 150 mm ⁽²⁷⁾ are also recommended.

Vent pipes may be made from bricks with cement mortar joints in the form of a chimney that is at least 225 mm² internally. ⁽²⁴⁾⁽²⁶⁾⁽²⁸⁾

The vent pipe should extend at least 500 mm above the highest point of a sloping roof. In the case of a conical shaped roof, it should be at least as high as the apex of the roof. ⁽¹⁰⁾⁽¹⁶⁾⁽²²⁾⁽²⁴⁾⁽²⁷⁾⁽²⁸⁾

An enlarged section (about 50 mm length) at the top of the vent pipe has been incorporated into certain designs in order to compensate for the reduction in effective cross-sectional area and air flow head loss due to the fly screen. ⁽²⁴⁾⁽²⁵⁾ Also there is a danger that cobwebs, dirt or insect matter may build up on the screen and restrict the air flow; beiling the top of the pipe can serve to balance these restrictions. ⁽⁸⁾ However, during the field studies in Zimbabwe it was found that this feature did not significantly increase venting capabilities, and is therefore not recommended. ⁽¹⁰⁾⁽²⁴⁾

The vent pipe must be straight, clear of the roof and must not protrude into the pit. ⁽⁴⁵⁾ The slab can be cast with a piece of wire across the vent pipe hole to prevent the pipe sliding down into the pit. ⁽²⁶⁾

13. Fly screen

By covering the top of the vent pipe with a fly screen, flies are prevented from entering the pit through the vent pipe and those which enter via the pedestal are trapped inside and will eventually die. ⁽¹⁰⁾⁽²⁶⁾

The fly screen should be made from corrosion resistant material. ⁽¹⁰⁾⁽³²⁾⁽³⁴⁾⁽²⁶⁾ Glass fibre screens have been found to be more durable than aluminum screens and less expensive than brass or stainless steel. ⁽²⁴⁾ PVC-coated glass fibre screens are effective for five years and with more permanent installations stainless steel screens can be used. ⁽²⁴⁾ Plastic fly screens are weakened by ultraviolet light and galvanized steel corrodes quickly. ⁽²⁶⁾

According to Rivett-Carnac glass-fibre reinforced plastic mesh with 1 mm x 1 mm openings has been found to be ideal. ⁽³²⁾ A mesh size of 1,2 mm x 1,5 mm can also be used. ⁽⁹⁾⁽²⁴⁾ If the apertures are larger small flies can pass through. If the apertures are smaller there is too much resistance to the updraught of air. ⁽⁹⁾

Gauze screens are secured horizontally over the top of the vent pipe so that leaves cannot accumulate on top. ⁽⁶⁾⁽¹⁰⁾ If the vent pipe is built of bricks the fly-proof screen should be stretched over the top surface of the highest bricks. If it is built into the course joint one brick below the top, a receptacle is created which catches leaves and other debris. ⁽⁹⁾ However, in rural areas the fly screen should be approximately 50 mm below the top of the vent in order to prevent eagles' claws from damaging them. ⁽⁴³⁾

The vent pipe must have a fly screen on top made from stainless steel or aluminium. ⁽²⁶⁾

14. Hand-washing attachments

The construction of a Blair latrine wash hand tank is an addition to the toilet to improve the personal hygiene of the users. ⁽³⁾ Such tanks or basins should provide a thin stream of water from a small diameter outlet that is just adequate to wash and rinse the hands, without wasting water. ⁽²⁶⁾ A water container with a small opening which can be closed with a match is often used. ⁽⁴⁷⁾

15. Groundwater pollution

Bacteria and viruses are the only excreted organisms of importance in groundwater pollution and the depth of soil above the groundwater table is the most important line of defence against them. ⁽¹⁸⁾

If groundwater pollution from VIP toilets might occur, alternative sanitation options should be considered or the polluted water should be treated before it is used. If the groundwater is being used as a source

of supply, the design of the toilet should be modified so that the groundwater is not polluted or the extent of pollution is acceptably low (faecal coliform counts below 10 per 100 ml).⁽¹⁶⁾

Systems which use more water will cause the contaminants to travel further, all other factors being equal, and this needs to be borne in mind when assessing the potential pollution impact of different types of on-site sanitation systems.⁽⁶⁾

The base of the pit should be at least 2 m above the water table of the underlying aquifer.⁽⁴²⁾ Under most conditions a depth of 2 m of unconsolidated material (silt or sand) is sufficient to avoid groundwater pollution.⁽¹⁶⁾

Pit depths should be restricted to a minimum, thereby increasing the attenuation zone between the effluent and the water table.⁽⁴²⁾ Contrary to this a greater depth (bigger pit volume) increases the lifetime of the pit.

If the water table is high, the toilet can be raised above ground level or the VIP system, with shallower pits, can be adopted.⁽⁴⁾ Otherwise the pit should be lined with acid peat if there is not enough soil material to serve as an attenuation filter.⁽⁴²⁾ Crawford recommends a T-piece connected to a soakaway downhill for a permanent high water table.⁽⁴²⁾

Raising the pit is essential when the groundwater is, either permanently or seasonally, within 0,3 m of the ground surface.⁽¹⁵⁾ In Zimbabwe it has been found that the ventilation performance of VIP toilets, where the water table is close to the surface, is still satisfactory provided that the cover slab is raised 300 mm above ground level⁽¹⁶⁾ and that raising the cover slab 0,5 m above ground level is an effective strategy under such high water table conditions.⁽⁴⁴⁾ The floor slab should not be raised higher than 1 m above the ground level.⁽¹⁶⁾

If the groundwater table is permanently near (within 0,3 m) or at the surface, and on a slope, a pit toilet should not be built. However, where the water table is high but fluctuates 1 to 2 metres on a seasonal basis, the pit could act as a septic tank, but the slab must be raised well above ground level.⁽⁶⁾

Pit toilets should not be constructed within the 1:50 year flood lines of rivers and streams.⁽⁴²⁾ Evans⁽⁶⁾ suggested that a pit toilet should not be built within 100 to 200 metres of a natural drainage course (stream, river, borehole or well), as this may cause a serious pollution problem.⁽⁶⁾ The minimum distance between a borehole and a pit toilet proposed for South Africa is usually about 30 metres, but is also dependent on the geotechnical conditions at the site.⁽⁴²⁾

In general, it appears that as long as there is sufficient depth of intact, unsaturated soil between the source of the contamination and the groundwater, bacterial contamination should not be a major problem. There is no consensus on exactly what constitutes "sufficient depth", and there is a need to establish appropriate guidelines.⁽⁶⁾ Unless the soil has a very open structure, or the water table is shallow, most harmful constituents will not reach underlying aquifers. The most serious concern is usually with regard to possible nitrate contamination of the groundwater, in particular where there are many VIP toilets in a small area.⁽⁴⁵⁾⁽⁴⁴⁾

16. Maintenance

Cleanliness is of the utmost importance. Squatting slabs and seats easily become fouled. Fouled and unhygienic pit toilets become a focus for disease transmission and may make matters worse than before.⁽⁷⁾ Therefore regular cleaning of the interior of the superstructure (floor slab and seat) is necessary.⁽⁴³⁾⁽⁴⁶⁾⁽⁴⁷⁾⁽⁴⁸⁾ The toilet slab should be washed down every day.⁽²⁰⁾

A superstructure that is left dirty and in a constant state of disrepair will soon be unused as a toilet and abandoned. It is therefore important that the superstructure is maintained properly. ⁽⁹⁾ Cracks in the walls, floor, door and roof of the superstructure should be repaired. ⁽⁴⁰⁾ The cover slab occasionally needs to be repainted with bitumastic paint. ⁽²⁴⁾ Poles, reeds or thatch in the structure should be checked for termite damage. ⁽¹⁰⁾

Periodically the stormwater diversion bank around the slab needs to be checked for erosion. A grass cover around the superstructure will prevent erosion. ⁽⁶⁾ The area around the toilet should be kept free from vegetation. ⁽²⁴⁾

The flyscreen, the vent pipe, the vent pipe opening in the slab, and the cover slab should be regularly inspected to ensure that they are in good condition. Any gaps and cracks should be repaired. ⁽⁴⁾⁽⁸⁾⁽¹⁰⁾

The flyscreen should be inspected each year and replaced if damaged. ⁽⁸⁾⁽¹⁰⁾ It should also be checked periodically to ensure that it is still intact. ⁽²⁴⁾

Once each month, a bucket of water should be poured down the vent pipe to get rid of spider webs. ⁽²⁴⁾⁽²⁷⁾⁽⁴⁰⁾

Because the VIP is a dry toilet excessive amounts of water must not be discharged into the pit. ⁽⁴³⁾⁽⁴⁾ Depending on soil conditions, small amounts of water (not more than one litre per day is recommended) assist in decomposition of the pit contents and can be added to the pit. The pit cannot be used for the disposal of bath water unless the subsoil percolation rate is very good. ⁽²²⁾

The pit must not be used for the disposal of household rubbish ⁽³²⁾ or non-decomposable rubbish, as this will shorten the life of the pit. ⁽⁶⁾⁽⁴⁰⁾

Refuse thrown into the pit may also hinder the emptying process. ⁽⁴⁾

Use toilet paper whenever possible. ⁽⁴⁰⁾ To discourage people from dropping pieces of paper on the floor a suitable container should be provided inside the toilet. ⁽⁴⁴⁾

The door (where fitted) and seat cover should be kept closed when the toilet is not in use. ⁽⁴³⁾⁽⁴⁾

At the end of each winter old engine oil should be rubbed into a wooden door to make it last longer. ⁽⁴⁰⁾

Disinfectants and antibiotics or chemicals should not be added to the contents of the pit. ⁽³²⁾⁽⁴⁰⁾ Because some pits smell people add disinfectants to them. This kills the bacteria and makes the pit fill quicker. ⁽⁴²⁾⁽⁴⁴⁾

If the pit extends below the groundwater table, mosquitoes tend to breed in them. Mosquitoes are less attracted to light than flies, and therefore many will leave the pit via the squat-hole or pedestal, even if the superstructure is dark. Mara ⁽¹⁶⁾ says that several substances which kill mosquito larvae can be added to the pit, for example, kerosene, used engine oil or chemical larvicides. However, it has been found that some of these substances destroy the bacteria which digest the faeces in the pit, and the use of substances other than vegetable oil is therefore not recommended. ⁽⁴³⁾ An alternative is to place a mosquito trap over the squat-hole. ⁽¹⁶⁾⁽²⁴⁾⁽³⁴⁾ Covering the surface water in the pits with polystyrene balls has also been found to be an effective mosquito control strategy. ⁽²⁴⁾

The pits of a VIDP toilet must be used alternately and not at the same time. ⁽⁴⁾ The drop-hole of the pit which is not in use should be well sealed. ⁽⁶⁾ The pits need to be emptied when they are full and the vent pipe, if there is only one, needs to be moved to the pit being used. ⁽²¹⁾

17. Solids accumulation

Urine as well as small amounts of water for cleaning the cover slab which are poured into the pit, infiltrate into the surrounding soil. Faecal solids in the excreta are digested anaerobically by bacterial activity. This, however, does not remove all the solids. Thus solids accumulate in the pit, although the rate of solid accumulation is much smaller than the rate of excreta addition. ⁽¹⁴⁸⁾

Factors affecting the rate of fill-up of the pit are:

- the extent of water flow through the pit
- the permeability of the soil surrounding the pit and the porosity of the pit liner
- the degree of pit ventilation ⁽¹⁴⁹⁾

By adding disinfectants to the pit, the bacteria are killed. This stops decomposition and increases the rate of sludge accumulation, whereas biological enzymes added every four months may promote the breakdown of the pit contents. ⁽¹⁴⁴⁾

18. Pit emptying

When single-pit VIP toilets become full, there are two options available to their owners. They can either construct a new toilet on an adjacent site, or empty the existing toilet. ⁽¹⁴⁵⁾

In rural areas construction of a new toilet, reusing as much of the materials from the old toilet as possible, is generally the preferred solution, as space for the new toilet is usually available. ⁽¹⁴⁶⁾ Pit emptying is essential if there is insufficient space to relocate the pit. ⁽¹⁵¹⁾

Manual emptying poses health risks due to the excreted pathogens and this is often not a socially acceptable task. Mechanical emptying is not normally feasible in rural areas. In urban areas manual emptying has the same disadvantages, but mechanical emptying might be feasible. ⁽¹⁴⁹⁾

Pit toilet emptying vehicles (vacuum tankers) have been used successfully for emptying pits. The use of such a vehicle is not recommended if pits are unlined, because this might erode the pit and lead to toilet collapse. ⁽¹⁵²⁾ However, unlined pits with a ringbeam can be emptied by hand. ⁽¹⁴⁸⁾ Desludging of lined pits results in a significant extension to the life span of the toilets at a minimal cost to owners. Furthermore, desludging is accompanied by minimal environmental degradation compared to what would be experienced if full pits were covered and replaced by new units. ⁽¹⁵³⁾

Dry pits are considerably more difficult to desludge mechanically than wet pits. A solution in urban areas is to use single-pit VIP toilets with soakaways or alternating twin-pit VIP toilets. ⁽¹⁴⁵⁾

All excreted pathogens die within twelfth months at temperatures above 20 °C ⁽¹⁴⁶⁾ and the risk involved in re-using faecal material that has been buried for at least twelve months is very small. ⁽¹⁷⁾ Therefore, one year is the minimum storage requirement for each pit. ⁽¹⁴⁹⁾ During physical-chemical emptying of toilets a chemical solution is added to the pit to destroy all visible pathogens. After about 20 minutes the contents of the pit can be emptied. The contents can be dumped into an adjoining pit. ⁽¹⁴⁴⁾

Local authorities often experience problems in providing a reliable, effective and affordable mechanized service to empty the pits, so planners should ensure that emptying can be done by the family, or by private entrepreneurs. This involves establishing not only that people are willing to handle stabilized humus, but also that there is some safe place for ultimate disposal (ideally, of course, on the family's vegetable patch or fruit trees). ⁽¹⁷⁾

The advantage of emptying is that it permits the facility to be a permanent one, and that it makes reuse of the excreta product possible. Disadvantages of pit emptying are that the purchase, operation and maintenance of specialized pit emptying equipment may be required, operational costs are higher and pit linings are required. Manual emptying should only be used with alternating twin-pit VIP toilets. It should only be used when it is both socially feasible and less expensive than mechanical emptying. ⁽¹⁵⁾

In Lesotho pit toilet sludge has been disposed of at nightsoil farms. These sites are fenced areas outside of the towns and away from habitation, where nightsoil from the bucket system is dumped into large hand-dug ditches. Unfortunately the ideal of regularly covering the waste does not work; in time the ditches fill up and a dry crust forms on the surface, which prevents any further drying underneath. ⁽¹⁾

19. Plot size and population density

In rural and urban areas up to a population density of around 300 persons per hectare (maximum of 250 persons per hectare according to Heap ⁽¹⁶⁾), the least-cost technically feasible sanitation technology will often be the VIP toilet. ⁽¹⁶⁾ Where the density of population is greater than 300 persons per hectare, a pit toilet should not be built. However, much will depend on the depth to which pits can be dug and the carrying capacity of the soil types involved. ⁽⁶⁾

Where plot sizes are really small, it may be feasible to locate the pit-access hatches outside the property itself (for example, under the edge of an alleyway, if there is no traffic). ⁽¹⁷⁾

If the number of users of a single-pit toilet is high (more than 10) then the required pit volume may be unacceptably large, especially if the solids accumulation rate is high. Under these circumstances the designer should assess the comparative feasibilities of the following options:

- an "alternating single-pit" VIP toilet system, where two single-pit toilets are used alternately for 5 years at a time (the pits being covered when full and re-excavated when needed again)
- one single-pit VIP toilet which is to be desludged mechanically every 3-10 years
- a single-pit VIP toilet with an individual or communal soakaway
- an alternating twin-pit VIP toilet which is to be desludged, manually or mechanically, every two to three years. ⁽¹⁸⁾

At higher densities alternating twin-pit VIP toilets may be feasible, but other options, such as solids-free sewers, may be a more appropriate solution. ⁽¹⁶⁾ The VIDP toilet can be particularly suitable for areas housing from 200 to 400 people per hectare, if the disposal of waste water is properly managed. ⁽⁶⁾ The idea of sharing a toilet between households is not socially acceptable, except in an emergency. ⁽¹⁾

A more serious problem, which may indeed lead to failure (or at least to the VIP toilet becoming unacceptable in the community) is progressive loss of ventilation as population density increases, houses are crowded together, and second storeys are added to some buildings. Ventilation efficiency fails as more structures obstruct the wind flow. A solution being tried in Jamaica is to build the vent pipe from 8 inch hollow concrete blocks. The hollows form twin chimneys for each pit and, if the vent does not work efficiently, it can be raised several courses. With mixed-height housing, or on steep slopes, however, there is the risk of ground level VIP's discharging odours at the window level of adjacent homes. ⁽¹⁷⁾

It is not realistic or technically supportable to suggest that the 'modern' ventilated pit privy improved matters by inducing large pit ventilating air flows that dilute and disperse pit odours to the atmosphere. The hydrogen sulphide smell which is the basis of pit odours, results from anaerobic conditions within the pit. The general stench noticeable in crowded areas will nevertheless remain the same, despite strong airflows through the pit and out the vent pipe. ⁽²⁶⁾

20. Conclusions

The Ventilated Improved Pit Toilet, when correctly designed, operated and maintained, has proved to be an acceptable, cost-effective, hygienic and environmentally friendly sanitation system. This research report has presented design and construction methodologies from many countries and has further highlighted the advantages and disadvantages of the various systems commonly used. Cultural and social criteria have been shown to play an important role in the choice of sanitation technology and also in the manner in which certain technologies are used. These factors should be taken into consideration in the implementation of any sanitation project.

The hardware and other technical aspects of VIP toilet design and construction, namely pits, cover slabs, superstructures, seats, vent pipes, fly screens and hand-washing attachments have been discussed. Maintenance matters such as solids accumulation and pit emptying were given attention, while factors contributing to groundwater pollution, as well as various socio-economic aspects which affect the operation and maintenance of VIP toilets, have also been examined.

The factors that have been identified as being of great importance with regard to the general acceptability of VIP toilets are:

- design and construction issues dealing with
 - safety
 - comfort
 - ventilation
 - user preferences
- social issues dealing with
 - education regarding proper use of the system
 - disposal of toilet wastes
 - maintenance of the system
- environmental and health issues dealing with
 - location of the toilets
 - pollution
 - personal hygiene of users.

21. Recommendations for further research

During the course of the research project it became evident that certain aspects of VIP toilet technology are in need of further research, as the information available was either scanty or inconclusive. The two most important aspects requiring further investigation are:

- the role of enzymes and bacteria in the operation and maintenance of pits; and
- the minimum required depth of intact, unsaturated soil between the pit and the groundwater in order to prevent bacterial contamination.

22. References

1. Blackett, I.C. *Low-Cost Urban Sanitation in Lesotho*. UNDP-World Bank Water & Sanitation Program, Washington, March 1994.
2. Boot, M. and Cairncross, S. *Actions Speak - The study of hygiene behaviour in water and sanitation projects*. IRC - International Water and Sanitation Centre, 1993.
3. Chidavaenzi, M.T. *The Blair Latrine Wash Hand Tank Construction Manual*. Blair Research Institute, Ministry of Health and Child Welfare, Zimbabwe, 1995.
4. De Villiers, D.C. *The Ventilated Improved Double Pit Latrine*. NBRI Information Sheet (X/BOU 2-68), National Building Research Institute of the CSIR, Pretoria, 1984.
5. Department of Water Affairs and Forestry. *Water Supply and Sanitation Policy - White Paper*. Department of Water Affairs and Forestry, Cape Town, November 1994.
6. Evans, A.C. *Construction Manual for the Pit Latrine in Rural Areas*. South African Medical Research Council, Nelspruit, 1987.
7. Feachem, R.G., Bradley, D.J., Garelick, H. and Mara D.D. *Appropriate Technology for Water Supply and Sanitation*. Transportation, Water, and Telecommunications Department of the World Bank, Washington, December 1980.
8. Fourie, A.B. and Van Ryneveld, M.B. *The fate in the subsurface of contaminants associated with on-site sanitation: A review*. Water SA vol.21 No. 2, 2 April 1995, pp 101-111.
9. Franceys, R., Pickford, J. and Reed, R. *A Guide to the Development of On-site Sanitation*.
10. Heap, M.A. *The Ventilated Improved Pit Latrine*. NBRI Information Sheet (X/BOU 2-71), National Building Research Institute of the CSIR, Pretoria, 1984.
11. Imiesa. *Water and Sanitation Education*. The Official Journal of the Institution of Municipal Engineers of Southern Africa, Imiesa Vol. 20 No. 5, May 1995, pp. 15-17.
12. Jeenes, Ken. *Mvula Trust Pilot Sanitation Project: Project Summary Report - Central Lowveld Rural Sanitation Project*. University of the Witwatersrand Rural Facility, University of the Witwatersrand, January 1995.
13. Jere, M., Dzatizei, A. and Murjoma, M. *Pit latrine emptying using motorised equipment*. 21st WEDC Conference, Sustainability of Water and Sanitation systems, Kampala, Uganda, 1995.
14. Kiggundu, B.M. *Physical-chemical emptying of latrines for sustainability*. 21st WEDC Conference, Sustainability of Water and Sanitation systems, Kampala, Uganda, 1995.
15. Mara, D.D. *Ventilated Improved Pit Latrines: Guidelines for the Selection of Design Options*. TAG Discussion Paper No. 4, UNDP and World Bank contribution to the International Drinking Water Supply and Sanitation Decade, Washington, 1985.
16. Mara, D.D. *The design of Ventilated Improved Pit Latrines*. TAG Technical Note No. 13, UNDP and World Bank contribution to the International Drinking Water Supply and Sanitation Decade, Washington, 1984.
17. Middleton, R.N. *Making VIP latrines succeed*. Waterlines, Vol. 13, No. 4, April 1995, pp. 27-29.

18. Morgan, Peter. *The Blair Latrine: A Builders Manual for the One Bag Model*. Mvuramanzi Trust, Harare, September 1994.
19. Morgan, Peter. *The Blair Latrine: A Builders Manual for the Two Bag Model*. Mvuramanzi Trust, Harare, September 1994.
20. Morgan, Peter. *The Blair Latrine: A Builders Manual for the 3 Bag Model*. Blair Research Laboratory, Ministry of Health, Zimbabwe, Harare, September 1992.
21. Morgan, Peter. *The Blair Latrine: A Builders Manual for the 4 Bag Model*. Mvuramanzi Trust, Harare, October 1994.
22. Morgan, Peter. *The Blair Latrine: A Builders Manual for the 5 Bag Model*. Mvuramanzi Trust, Harare, August 1994.
23. Morgan, Peter. *The Blair Latrine: Builders Manual for a Double Compartment Blair Latrine*. Mvuramanzi Trust, Harare, September 1994.
24. Morgan, P.R. and Mara, D.D. *Ventilated Improved Pit Latrines: Recent Developments in Zimbabwe*. World Bank Technical Paper No. 3, Technology Advisory Group and World Bank, Washington, 1982.
25. Murphy, C. and Still, D. *Mvula Trust Sanitation Workshop: Workshop Report (Valley Trust, 25 to 28 January 1995)*. Pietermaritzburg, July 1995.
26. Murphy, C. and Still, D. *Report on the second Mvula Trust Pilot Sanitation Workshop at Hunter's Rest (19 to 21 September 1995)*. Pietermaritzburg, December 1995.
27. Nyagwaya, D. *A handbook for village health educators - for use in the self-help environmental sanitation programme Botswana*. Ministry of Local Government and Lands, Republic of Botswana and The United Nations Children's Fund, June 1985.
28. Pacey, A. *Sanitation in Developing Countries*. John Wiley and Sons, Chichester, July 1981.
29. Palmer Development Group, *Water and Sanitation Handbook for Community Leaders*. Report No. TT 68/95 to the Water Research Commission, Kenilworth, October 1994.
30. Pickford, J. and Reed, R. *Technical Brief No.45: Latrine slabs and seats*. Waterlines Vol 14 No.1, July 1995, pp. 15-18.
31. Puddifoot, J. *Pit latrines in Nepal - the refugee dimension*. Waterlines Vol.14 No.2, October 1995, pp. 30-32.
32. Rivett-Carnac, J.L. *Guidelines for Ventilated Improved Pit Latrines and Alternative On-site Sanitation Systems*. Appropriate Technology Information, Pietermaritzburg, November 1989.
33. Ryan, B.A. and Mara, D.D. *Pit Latrine Ventilation: Field Investigation Methodology*. TAG Technical Note No. 4, UNDP and World Bank contribution to the International Drinking Water Supply and Sanitation Decade, Washington, 1983.
34. Ryan, B.A. and Mara, D.D. *Ventilated Improved Pit Latrines: Vent Pipe Design Guidelines*. TAG Technical Note No. 6, UNDP and World Bank contribution to the International Drinking Water Supply and Sanitation Decade, Washington, 1983.

35. Solsona, Felpe. *The South African SanPlat: An alternative low-cost pit latrine system for rural and peri-urban areas*. A Technical Guide by the Division of Water Technology, CSIR, Pretoria, September 1995
36. Van Nostrand, J. and Wilson, J.G. *The ventilated improved double-pit latrine. A construction manual for Botswana*. TAG Technical Note No. 3, Government of Botswana, UNDP and World Bank contribution to the International Drinking Water Supply and Sanitation Decade, Washington, 1983.
37. Van Nostrand, J. and Wilson, J.G. *Rural Ventilated Improved Pit Latrines: A Field Manual for Botswana*. TAG Technical Note No. 8, Government of Botswana, UNDP and World Bank contribution to the International Drinking Water Supply and Sanitation Decade, Washington, 1983.
38. Schroeder, R.J.H. *Aspects to be considered when designing pit privies*. SA Water Bulletin, July 1994, pp. 24-25.
39. Solsona, F. *The South African SanPlat*. Development Services and Technology Programme, Division of Water Technology, CSIR, Pretoria, September 1995.
40. University of the Witwatersrand. *The VIP Latrine for Family Health: A Community Learning Manual*. The University of the Witwatersrand's Rural Facility and Health Services Development Unit and Communities and Health Services of the Central Lowveld District.
41. University of the Witwatersrand. *Single VIP Latrine and Spiral VIP latrine drawings*. University of the Witwatersrand, Rural Facility, Rural Engineering Programme, February 1995.
42. Xu, Y. and Braune, E. *A Guideline for Ground Water Protection for the Community Water Supply and Sanitation Programme*. Department of Water Affairs and Forestry, Pretoria, 1995
43. Personal interview: Don Crawford (Institute of Natural Resources)
44. Personal interview: James Rivett-Carnac (Appropriate Technology Information)
45. Personal interview: David Still (Partners in Development CC)
46. Personal interview: Barry Jackson (Development Bank of South Africa)
47. Personal interview: Martin Rall and Daniel Carter (Mvula Trust)

oo0oo



1868456471